

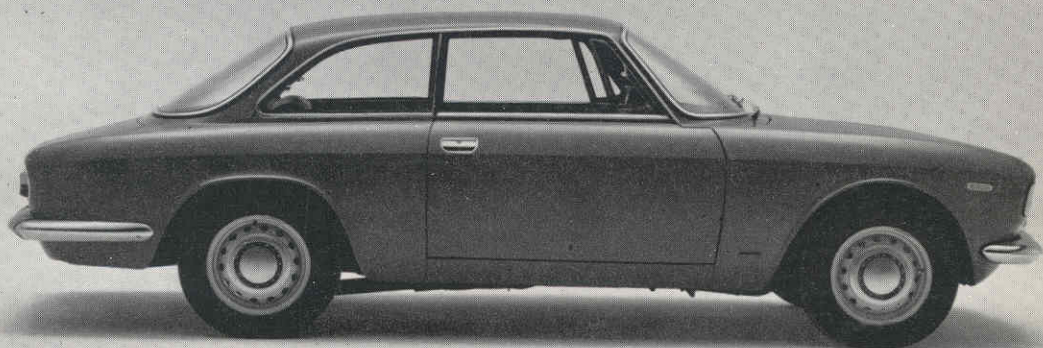

ALFA ROMEO GT 1300 JUNIOR



INSTRUCTION BOOK

WARNING

Beware of the danger of carbon monoxide! Never run the engine in an enclosed space. The exhaust gases contain carbon monoxide, a deadly gas. Carbon monoxide is particularly dangerous as, being it colorless, odorless and tasteless, its presence is very difficult to detect.

Keep a record of the symbol stamped on the key handle.

Ignition and antitheft device key

SYMBOL

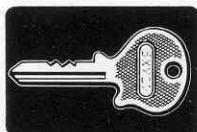

Key to doors, glove compartment, boot lid

SYMBOL

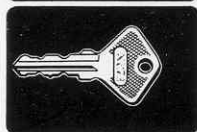

When ordering duplicate keys, **please quote the symbol.**



The operation and maintenance instructions contained in this handbook

MUST BE CAREFULLY OBSERVED



by every owner who desires to get the best from this vehicle and to ensure a long life for every component.

Owners are recommended, in their own interest, to entrust all maintenance and repair work to an authorized Alfa Romeo Service Station as such Stations are equipped with the proper tools and staffed by specially trained mechanics who are kept up-to-date by our technical literature.

Owners are reminded that Alfa Romeo cannot be responsible for any errors made by unauthorized service stations or for any damage resulting from the use of nongenuine spare parts and/or lubricants other than those indicated.

Direzione Assistenza



The data relating to weights, consumptions and speeds are approximate only; Alfa Romeo reserves the right to change without notice any features and data given in this book.

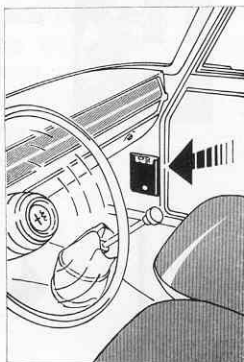

Alfa Romeo take steps to ensure the optimum performance of their cars by providing Clients with special services during the entire life of their vehicles.

The **Service Coupon Book**, supplied with every new vehicle, bears the conditions that govern the provision of Alfa Romeo Services and the replacement of damaged parts during the period covered by the guarantee.

Every purchaser of an Alfa Romeo motocar is supplied with two coupons covering certain free maintenance during the guarantee period, and he **must use these coupons on completion of the mileage as stated thereon.**

The labour cost of the maintenance work listed on the coupons is free, but the lubricants used are to user's account.

Any work not covered by free coupons but found necessary during the inspection will be subject to the General Terms of Guarantee. The coupons should be used whenever possible at the garage of the Agent that sold the car and during normal working hours.

GUARANTEE



The Supplier guarantees the products of the Factory for 6 months from the date of delivery to the Client; guarantee does not cover tyres and non-essential accessories if made by third parties, nor does it cover spare parts.

The guarantee covers the free repair of, or free supply and replacement of, any parts found to be unserviceable **because of an acknowledged defect of materials**; defects will be acknowledged after prior investigation of them and of their cause exclusively by the manufacturer's workshops or by workshops authorized by the manufacturer, and at the said workshops.

Should the Purchaser insist on the services of an Alfa Romeo technician for the purpose of inspecting faulty or allegedly faulty parts, the expenses of such a technician will be the responsibility of the Purchaser. **Delays, if any, shall not entitle the Purchaser to receive compensation for damages, nor to any extension of his rights under the guarantee.**

The guarantee shall lapse automatically:

if the products are used otherwise than in accordance with the manufacturer's instructions;
if they are modified, repaired or dismantled elsewhere than in the manufacturer's workshops or workshops authorized by the manufacturer;
if bodies of different origin which have not been previously approved by the manufacturer are fitted to the chassis.

The Purchaser shall not be entitled, in any of the cases stipulated by this article, to claim cancellation of the Contract or compensation for damages.

Contents

- 2 Service Coupon Book
- 3 Guarantee
- 5 Identification
- 6 Specification
- 8 Controls and instruments
- 10 Running in

HOW TO USE YOUR CAR

- 11 Starting the engine - antitheft
- 12 Starting the engine (from cold, when hot)
- 13 Dip and light switch
- 14 Precautions (while driving & parking)
- 15 Winter precautions
- 16 Ventilation, demisting and heating
- 20 Interior
- 22 Radio equipment
- 23 Safety belts
- 24 Doors
- 25 Engine bonnet - Luggage boot and tool kit
- 26 Wheel removal
- 27 Towing

LUBRICATION

- 28 Regular lubrication schedule
- 29 Regular lubrication and lubricants
- 30 Engine
- 31 Oil pump and filter

MAINTENANCE

- 32 Regular maintenance schedule
- 33 Regular maintenance

ENGINE MAINTENANCE

- 34 Tightening torque specifications
- 35 Valve timing
- 37 Fuel feed
- 40 Ignition
- 44 Cooling system

CHASSIS MAINTENANCE

- 46 Clutch
- 48 Gearbox
- 49 Propeller shaft
- 50 Rear axle
- 51 Front suspension
- 52 Rear suspension
- 53 Steering gear and linkage
- 54 Front wheels (toe in)
- 55 Front wheels (camber)
- 56 Brakes
- 66 Wheel balancing
- 66 Tyres (inflation pressures)
- 68 Tyres (changing over)

69 BODY MAINTENANCE

70 LAYING THE CAR UP PRECAUTIONS

ELECTRICAL EQUIPMENT

- 71 Battery
- 72 Generator, starting motor
- 73 Headlamp beam setting
- 74 Wiring diagram

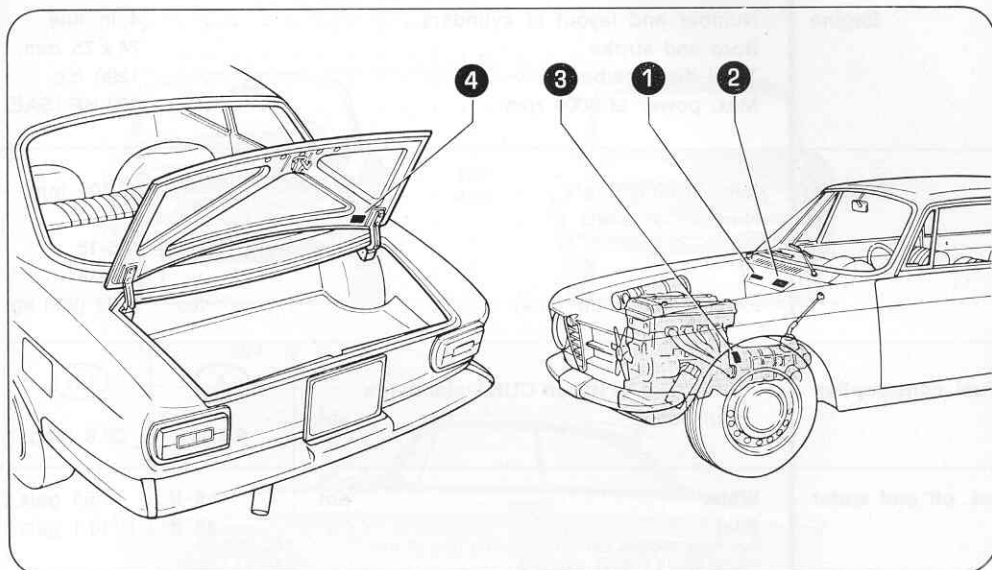

On bulkhead panel

- 1 Chassis serial no. (metal stamped)
- 2 Identification plate (car model & type approval number)

- 3 **On crankcase** (exhaust side)
Engine no. (metal stamped on gearbox/engine joining flange)

- 4 **On luggage boot lid**
Finish plate (paint type & make)

On contacting the Factory or a Member of our Service Organization please state: car model, chassis no., registration date, distance covered and car's purchase data.



Specification

Engine	Number and layout of cylinders	4 in line
	Bore and stroke	74 x 75 mm.
	Total displacement	1290 c.c.
	Max. power at 6000 rpm	103 HP (SAE)

Chassis	Min. turning circle	10,700 mm.
	Number of seats	4
	Tyres	{ 155-15 165-14
	Kerb weight (full tank)	lbs 2182 (990 kg)

Fuel consumption	Per 100 Km to Italian CUNA standards (full load) abt.	(I)	(GB)
		9.8 lt	28.8 mpg

Fuel, oil and water	Water abt.	7.5 lt	1.65 gals
	Fuel »	46 lt	10.1 gals
	For best engine performance the use of premium grade fuel is advised.		
	Fuel reserve »	6 to 7 lt	1.3-1.5 gals
	Engine (sump and filter) when full ★ »	5.80 Kg	5.75 qts
	danger level »	4.00 Kg	3.95 qts
	Gearbox »	1.65 Kg	3.2 pts
	Differential »	1.25 Kg	2.5 pts
	Steering box BURMAN »	.36 Kg	.7 pt
	★ This quantity is that needed for regular changing. The total amount of oil in the circuit (sump, filter and passages) is »	6.55 Kg	6.5 qts

PERFORMANCE
(with 41 : 9 final drive)

GEAR	AFTER RUNNING IN	
	Km/h	mph.
1st	44	27
2nd	74	46
3rd	108	67
4th	146	91
5th	170 over	105
Rev.	48	30

The maximum speeds indicated should not be exceeded or mechanical damage may result.

The performances given are related to the use of the vehicle in normal travelling conditions in Central Europe.

Alfa Romeo GT 1300 Junior

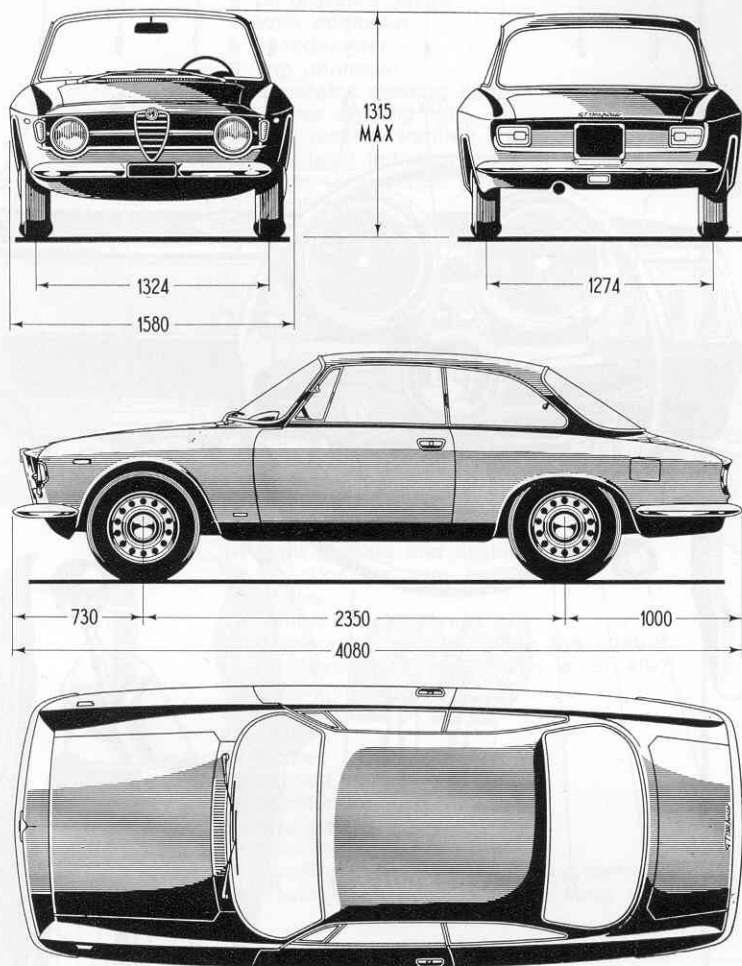

730 mm = 28.7"

1000 mm = 39.4"

1274 mm = 50.1"

1315 mm = 51.8"

1324 mm = 52.1"

1580 mm = 62.2"

2350 mm = 92.5"

4080 mm = 160.6"

Dimension in mm - overall height with unladen car

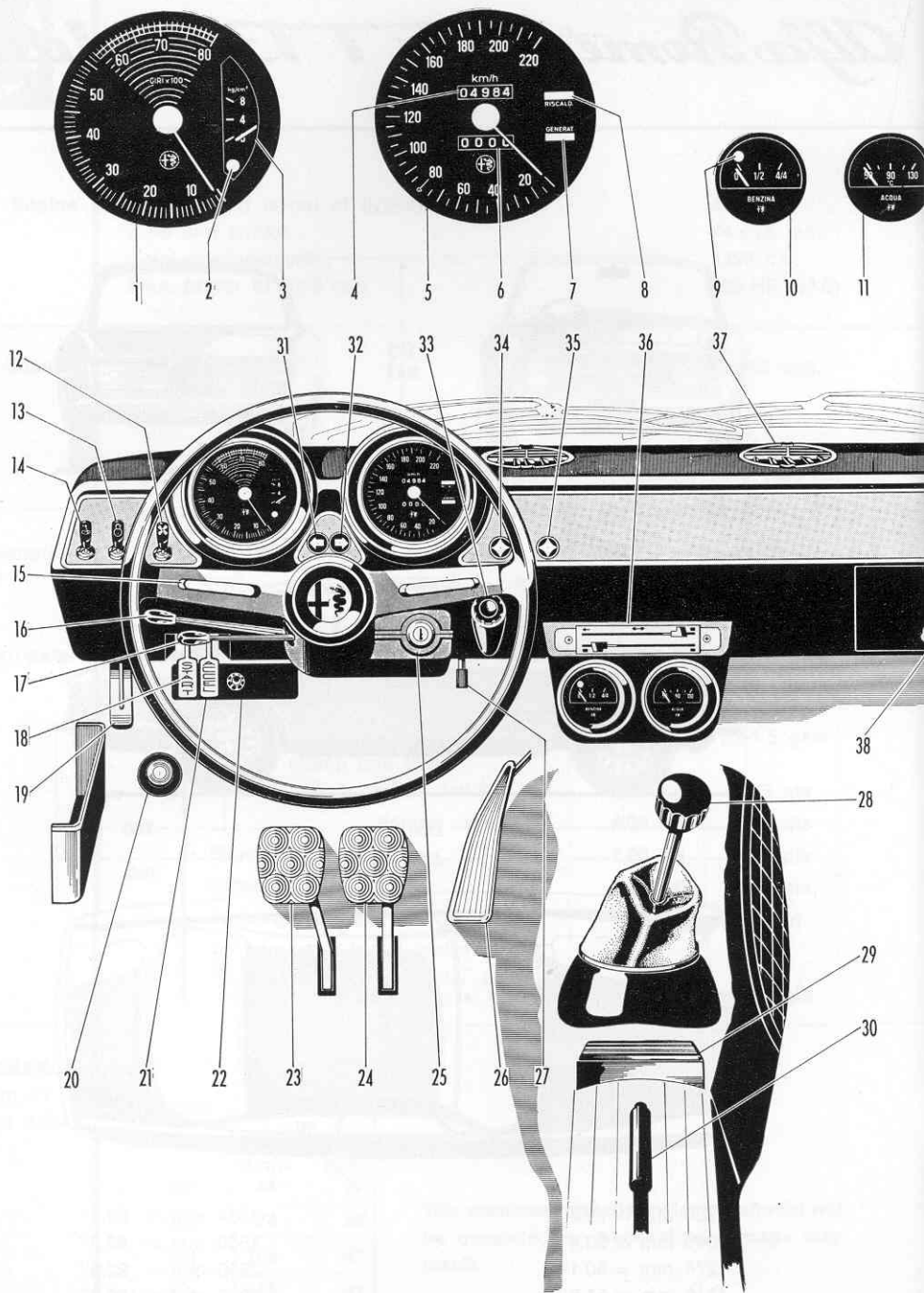

To engage the REVERSE merely shift the lever from neutral (F) as shown. ►

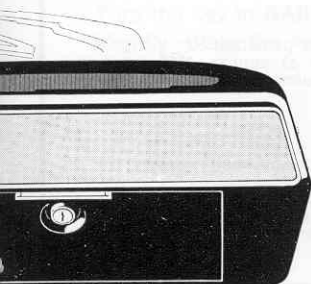

- 1 Tachometer
- 2 Warning light for oil pressure
- 3 Oil pressure gauge
- 4 Main odometer
- 5 Speedometer
- 6 Trip odometer
- 7 Generator warning light
- 8 Blower warning light
- 9 Fuel reserve warning light
- 10 Fuel level indicator
- 11 Water temperature gauge
- 22 Fusebox
- 31 Warning light for L.H. direct. indicator
- 32 Warning light for R.H. direct. indicator
- 34 External light warning
- 35 Headlamp high beam warning light

Instruments

- 12 Blower switch (2-speed)
- 13 Instrument light switch (operates when external lights are on)
- 14 Windscreen wiper switch (2-speed)
- 15 Horn
- 16 Light dipping and flashing switch
- 17 Direction indicator switch
- 18 Choke
- 19 Bonnet catch release
- 20 Windscreen washer: when the control is pressed the windscreen wiper also comes into action
- 21 Hand throttle
- 23 Clutch
- 24 Brake
- 25 Ignition switch & antitheft
- 26 Accelerator
- 27 Trip odometer reset
- 28 Gear lever
- 30 Handbrake (for emergency and parking)
- 36 Heating, ventilating and demisting

Controls

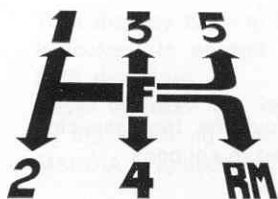

- 29 Ash tray
- 33 Cigarette lighter: insert cigarette, press down outer edge of the lighter: this brings into operation an electric element which lights the cigarette and turns itself off after a few seconds.
- 37 Air outlets (adjustable)
- 38 Glove compartment

Luxury fittings

**WARNING FOR
THE FIRST
1900 miles
(3000 km.)**

RUNNING IN

To allow the various parts of the car, **particularly the engine, gearbox and differential**, to settle in gradually, a running-in period is necessary, during which maximum performance must not be demanded of the car.

RECOMMENDATIONS FOR THE FIRST 1900 MILES

Mileage	Max. engine RPM	
Up to 600	3500	Cold starting: — press in choke as soon as possible; — before driving, run engine at approx. 1500 r.p.m. for at least 1 minute in summer and 2-3 minutes in winter. While driving: — do not drive at max. recommended speeds for long periods; — never fully depress the accelerator pedal; — now and then release the accelerator pedal; — avoid full and extended braking during the first 600 miles.
601 to 1900	4500	

RECOMMENDATIONS FOR THE FIRST 3000 KM

Kiloage	Max. engine RPM		
Up to 1000	3500	Cold starting: — press in choke a — before drive While driving — do not d — now — avoi — never	DURING RUNNING-IN STRICTLY FOLLOW THE ABOVE INSTRUCTIONS! Note: The same recommendations apply also in the case of engine re-conditioning involving the replacement of cylinder barrels, pistons, piston rings and bearings.
1001 to 3000	4500		

FREE SERVICE COUPONS

COUPON A
COUPON B

At the first **450- 750 mi. (700-1200 Km)** } carry out the free servicing
 At the first **3100-3750 mi. (5000-6000 Km)** } included in coupons

How to use your car

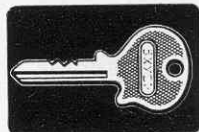

STARTING THE ENGINE

Insert the key.

Turn the key to **GARAGE** position. To help in freeing the steering lock, slightly rotate the wheel in both directions.

Turn the key to **MARCIA** position. Ignition circuits are on (generator warning light lit).

Turn the key further to **AVVIAM**. The starting motor comes into action and the key, as soon as released, returns automatically to **MARCIA**. If the engine fails to start, the key must be returned to **GARAGE** and the operation repeated.



STOPPING THE ENGINE

Return the key to **GARAGE**. In such a position the ignition is « off » and the wheels can be steered even if the key is withdrawn.

ANTITHEFT/STEERING LOCK

Turn the key back to **BLOCCO**. By withdrawing the key the steering is locked; to engage the lock properly, slightly rotate the wheel in both directions.

Never withdraw the key before the car has come to a complete stop as the « steering lock » condition may occur.

MARCIA = ignition; AVVIAM. = starting; BLOCCO = lock.



From cold

Before starting the engine make sure the gear lever is in neutral. Pull out the choke, insert the key in the ignition switch and start the engine. Particularly when starting from cold in winter, it is advisable, in order to facilitate starting, to press the clutch pedal down fully and the accelerator through about one quarter of its stroke while at the same time operating the choke lever.

As soon as the engine fires release the ignition key.

If the engine fails to start at once, do not keep the starting motor running (or the battery will soon become discharged) but wait a few minutes and try again.

If it still will not start, look for the cause as follows:

- the battery charge may be too weak to rotate the starting motor sufficiently fast to start the engine;
- the Ignition equipment may be defective (dirty plugs, oxidized contact-breaker points, wet or cracked distributor cap, damaged distributor or coil);
- the carburettor may be dirty and jets clogged;
- electric circuits may be broken or fuses blown.

When the engine has started, move choke lever halfway back until the engine is warm and then push it down.

Do not accelerate the engine until it has warmed up, since when the engine is cold the oil cannot reach all points requiring lubrication.

Make sure the oil pressure shown by the gauge is as prescribed and the **oil pressure warning light goes off** as soon as the engine speed exceeds idling.

Make sure the generator warning light goes off as soon as engine speed exceeds idling.

Hot engine

In summer, or when the engine is already hot, do not use the choke. Starting will be facilitated if the accelerator is depressed about half way so that the carburettor throttle is opened in order to lean the mixture.

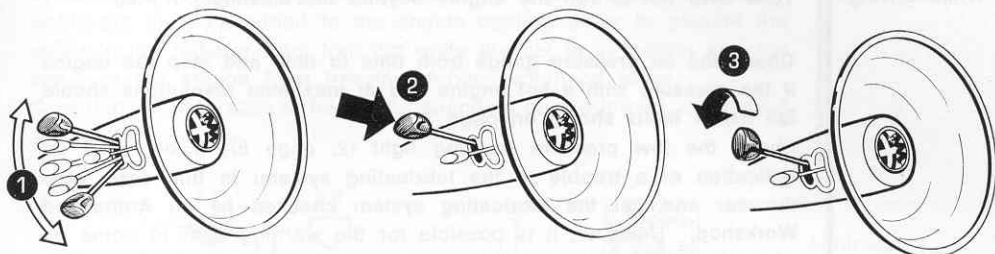

The switch lever may be in either of the two positions. The warning lights on the dashboard are out.

❶ Lights off

Press on the knob irrespective of the position of the switch.

❷ Flashing

Irrespective of the position of the lever, turn the knob to the first notch. The warning light (34, page 8) on the dashboard will light up and flashing is still possible by pressing the knob.

❸ Parking lights and number plate light

From position 3 turn the knob forward to the second notch.

If the lever is up, the **dipped lights** come on (no flashing).

If on the other hand, it is down, the **beam lights** and the respective warning light (35, page 8) come on (flashing possible).

The movement of the lever up and down allows the light to be **dipped** or returned to **beam**.



The lights are extinguished by turning the knob back over the notches.

❶ Lights off

While driving

Take care not to run the engine beyond the maximum R.P.M.

Check the oil pressure gauge from time to time and stop the engine if the pressure with a hot engine and at maximum revolutions should fall below limits shown on page 31.

Check the low pressure warning light (2, page 8): if on, it is an indication of a trouble in the lubricating system: in this case, stop the car and get the lubricating system checked by an Authorized Workshop. However, it is possible for the warning light to come on when the car is cornering: this may be caused by a low level of oil in the sump which can be easily remedied by topping up.

No trouble exists if the warning light comes on while the engine is idling, especially when hot.

Do not drive at high speed until the oil in the engine, in the gearbox and in the differential has warmed up properly.

When shifting gears, take care to depress the clutch pedal fully; this will ensure smooth operation of gearbox and save synchronizers from excessive wear.

Do not rest your foot on clutch pedal when not actually using it.

The level of coolant in the radiator should be about 1 inch (2 to 3 cm) below the bottom rim of the filler orifice. If the level should drop to 2 inches (4 to 5 cm) when the engine is running, it is unnecessary to fill up provided that it does not continue to fall.

To check the coolant level when the engine is hot, and particularly when gauge shows a temperature around 212 °F (100 °C), it is essential to turn the radiator cap only as far as the first notch to allow the pressure within the radiator to drop. If a large quantity of water has to be added to a hot engine, the water should be poured slowly and the engine left running so as to prevent any sudden cooling and the possibility of damage.

While parking

Never leave the key in the « **MARCIA** » position (ignition «on») to prevent battery discharge and coil damage. Apply the hand brake and, when parking the car uphill or downhill, shift into a low gear and steer the front wheels in such a direction as to cause the car, should the hand brake disengage accidentally, to move toward the kerb.

In places where the temperature falls below freezing point, a suitable antifreeze must be added to the engine cooling water to prevent the water in the radiator from freezing while the car is in motion and the water in the engine from freezing during prolonged stops. Quantities of antifreeze to be used, depending on the lowest anticipated temperature:

Antifreeze

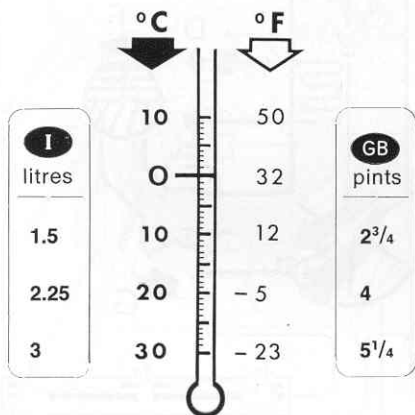

Recommended products		Antifreeze std. no. 3681.69956/1
		F1 antifreeze
		Antifreeze
		Antifreeze

Draining off the water

In icy weather even a short stop may be enough to freeze the engine water if an antifreeze has not been added.

If no antifreeze is used, **to avoid very serious damage**, it is essential to drain the radiator, the engine and the heating system by opening the cocks positioned at the bottom of the radiator and on the left-hand side of the engine and by shifting the heater temperature control to the 3A. position (see page 16).

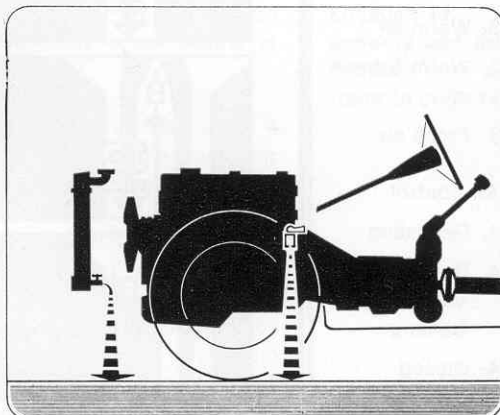

How to use your car

Operating diagram

- A** Air inlets in engine bonnet
- B** Air shutter
- C** Electric blower
- D-E** Water pipes
- F** Windscreen demisting slits
- G** Air outlets into car

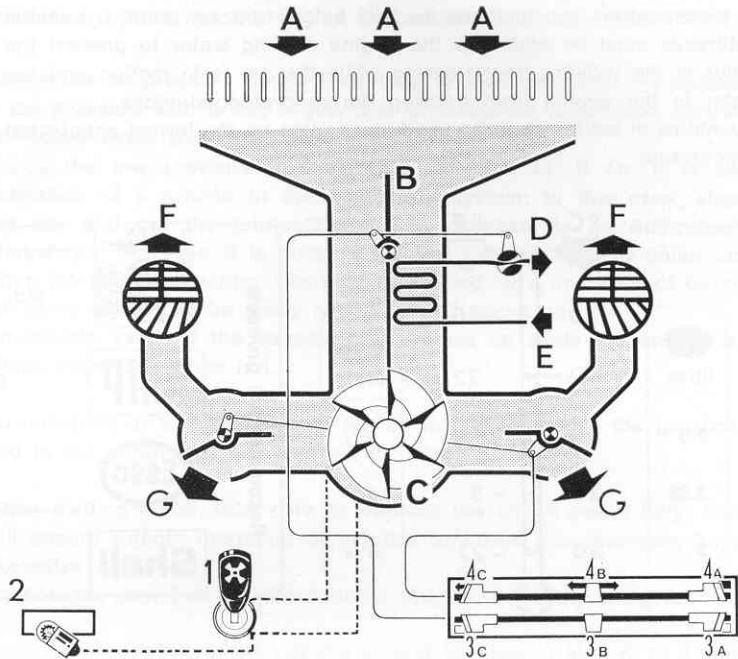

1 Blower switch

2 Blower operation warning light

- Temperature control

3_A Warm air

3_B Warm & fresh air

3_C Fresh air

- Air control

4_A Demisting

4_B Demisting ventilation heating

4_C Closed

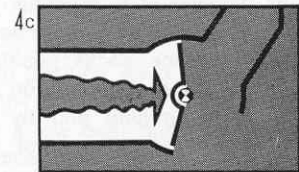
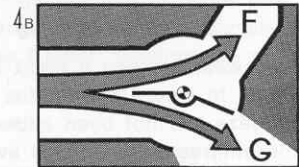
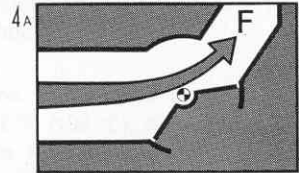
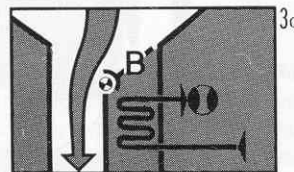
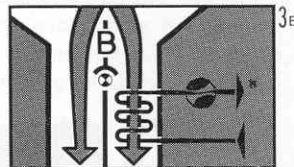
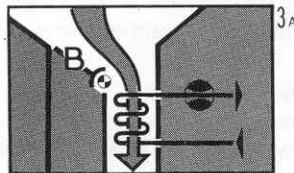

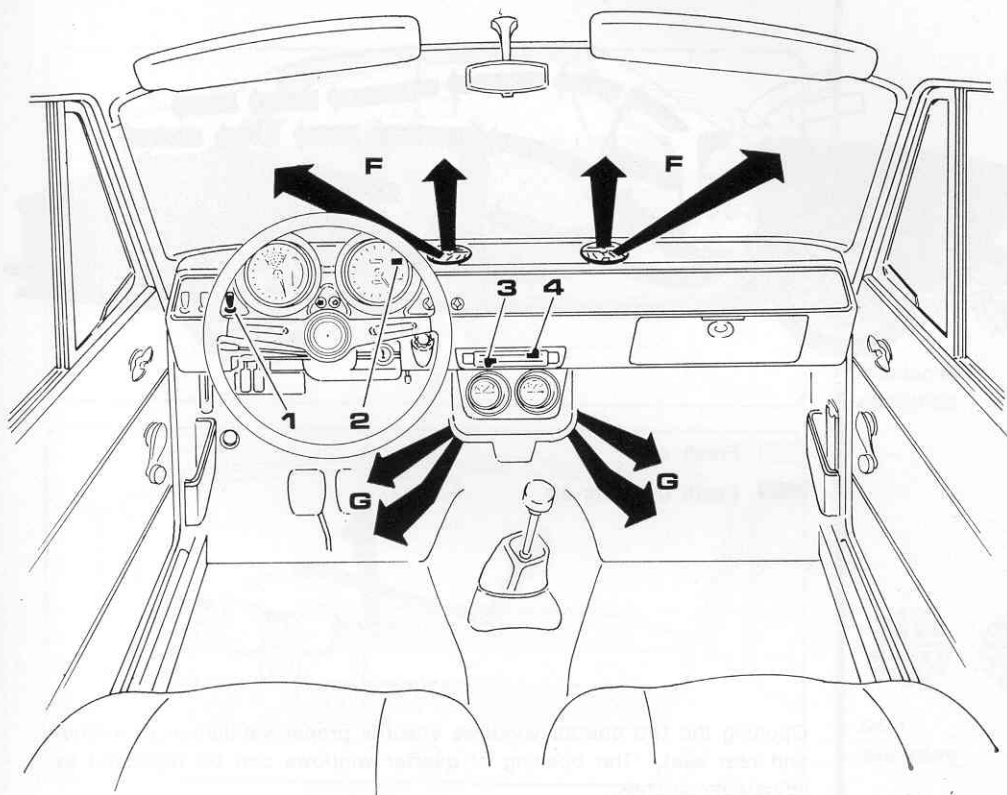

From **A** air enters through:

- **F** for windscreen demisting (warm and fresh air)
- **G** for ventilation and heating

Controls

- The air admitted to the car can be gradually heated by the movement of the lever **3** which operates the shutter **B** and the cock



D in the water pipes (operate this lever only when engine is warmed up).

- The movement of the lever **4** gradually regulates the flow of air through the openings **F** and **G**.
- In order to produce a satisfactory flow of air into the car at low speeds, switch on the two-speed electric blower by means of switch **1**. Warning light **2** indicates that this has been done.

Location of controls and air outlets
(refer to page 16)

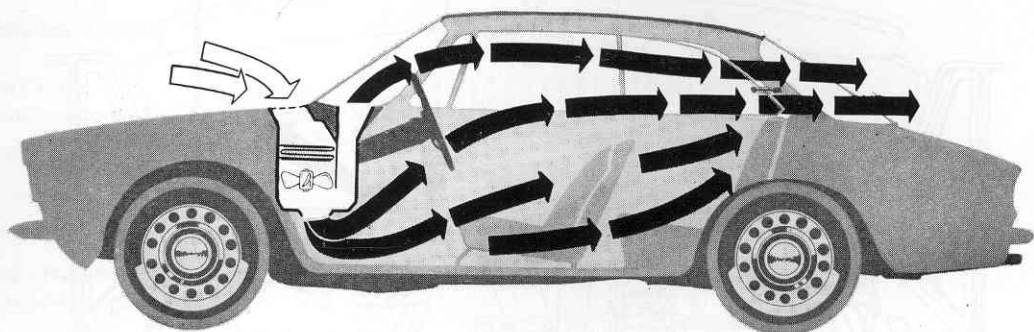
How to use your car



-  Fresh air
-  Fresh or warm air

Opening the two quarter windows ensures proper ventilation of interior and rear seat. The opening of quarter windows can be regulated by adjustable catches.

Quarter windows

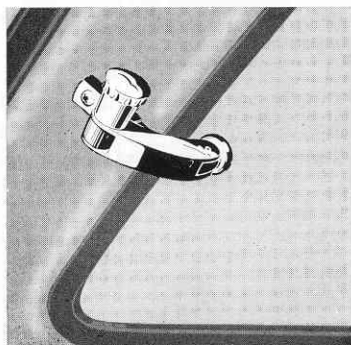

CLOSED

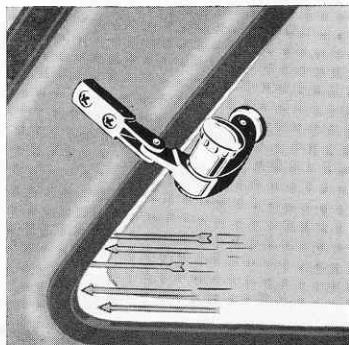

OPEN

How to use your car

VENTILATION DEMISTING AND HEATING

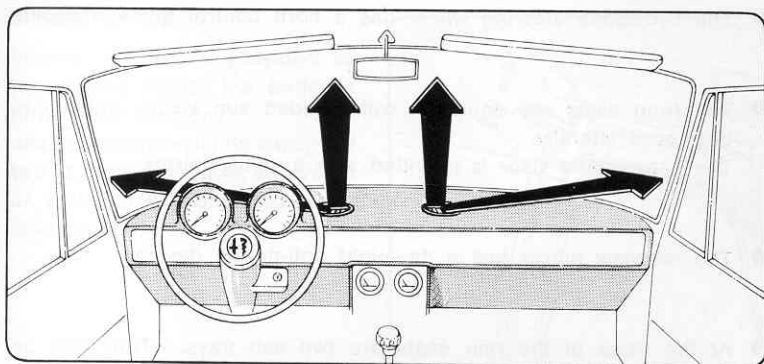

**Windscreen
demisting**

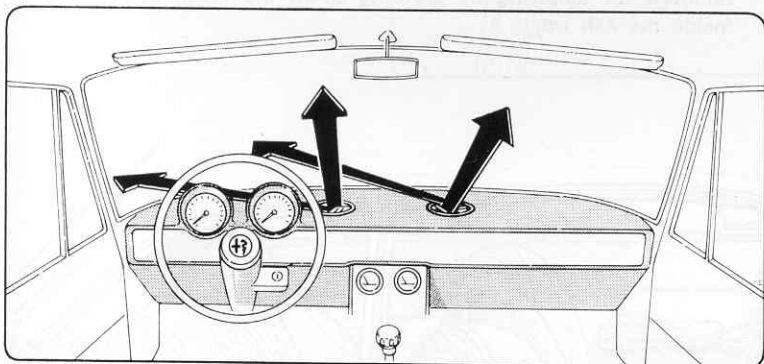

**Spot
demisting**

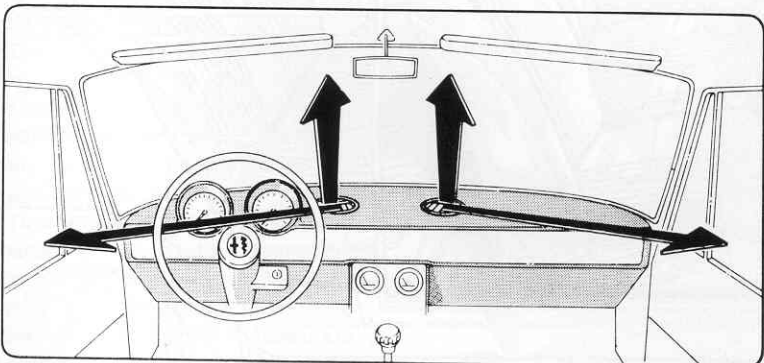

**Windscreen and
front windows
demisting**

The illustrations show some examples of outlet positions.
The outlets can be rotated by hand as desired.

- Steering wheel** ● The two-spoke steering wheel has a horn control in each spoke.
- Sun visors** ● The front seats are equipped with padded sun visors which can be moved laterally.
The passenger's visor is provided with a vanity mirror.
- Rearview mirror** ● The rearview mirror has a day-night anti-dazzle device.
- Ash trays** ● At the sides of the rear seats are two ash trays. They can be removed for emptying by pressing down the small central spring inside the ash tray.

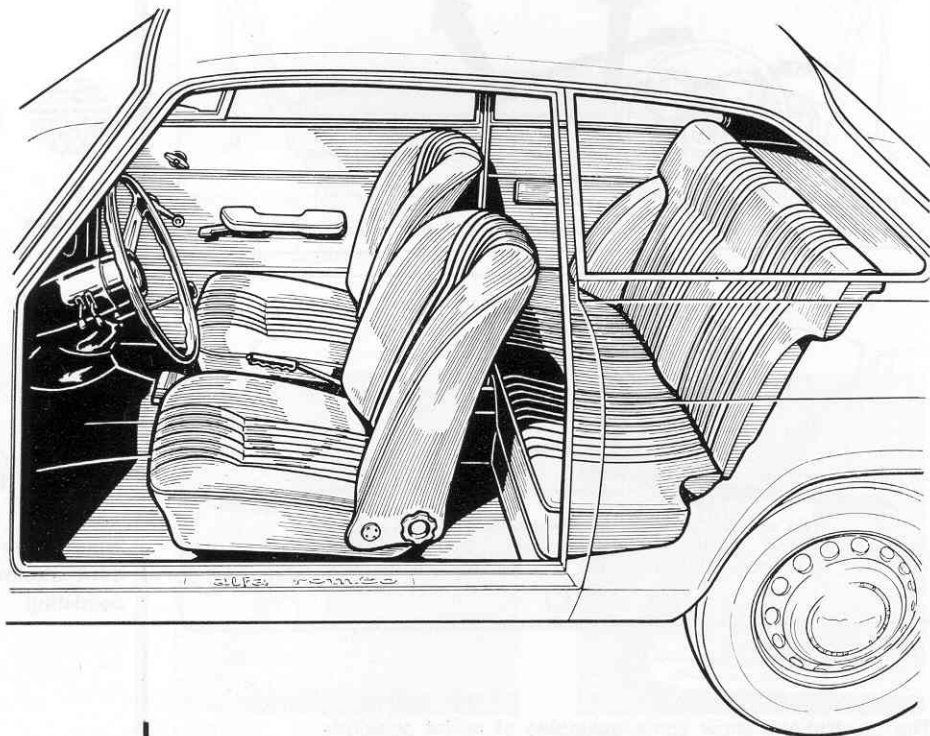

Internal lighting

Internal lighting is provided by two ceiling lights; the switches have three positions:

one in the centre: lights always off

two at the sides: lights always on or automatically operated when opening doors.

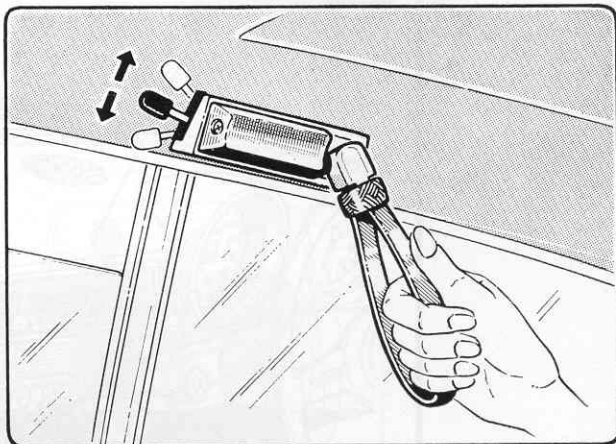

Front seats

The bucket type front seats have adjustable backrests.

The positioning of the front seats is controlled by the lever **1** situated on the front edge of each seat: by freeing the lever the seat may be moved to the position desired.

The knobs **2** at the outboard sides of the seats control the angle of the backrests; these may also be tipped forward to facilitate access of passengers to the rear seat.

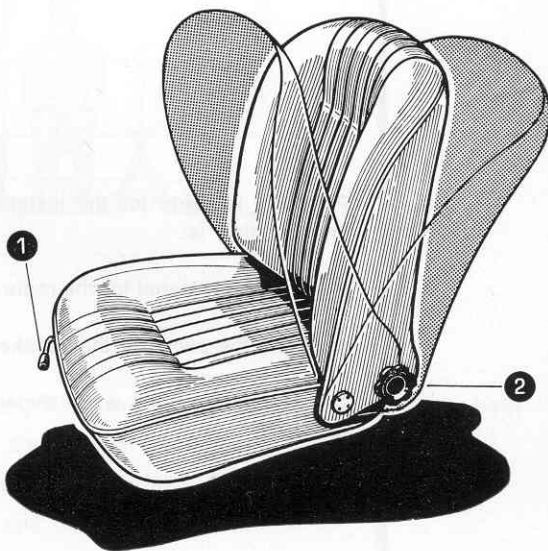

Rear seat

Bench or sofa type seat is provided optionally.

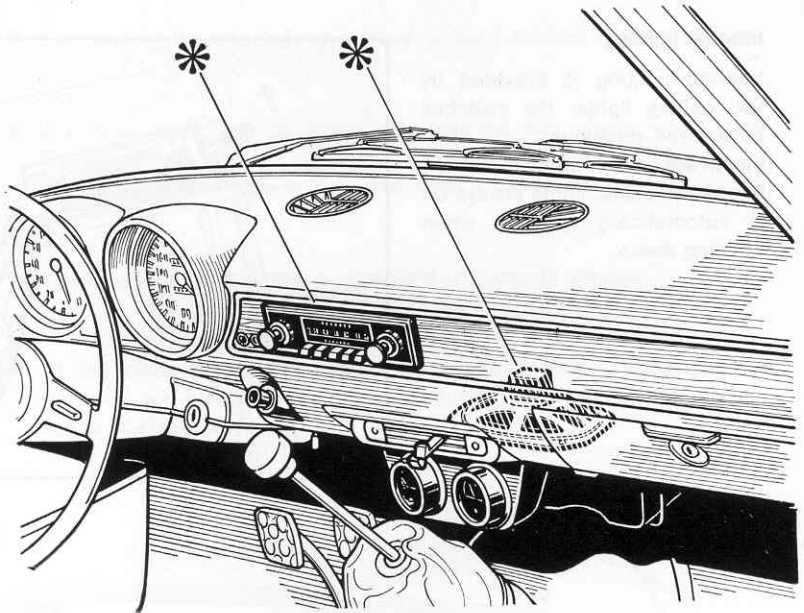

Radio

Provision is made for the installation of the radio equipment.
The location is:

- * in the facia panel for the radio set;
- * under the panel for the speaker.

The equipment is on when the ignition key is in **GARAGE** or **MARCIA** positions.



SHOULDER

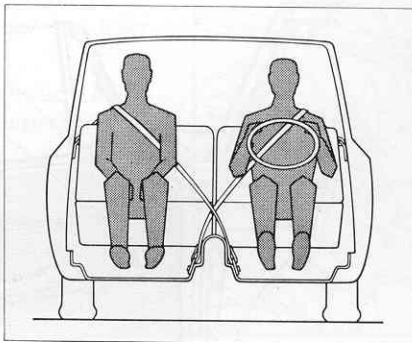

LAP

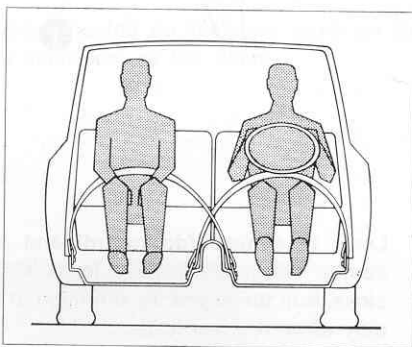

Provision is made for the fitting of safety belts to front seats.

Suitably reinforced attachment points are located:

- for shoulder belts: on the central tunnel and on side pillars
- for lap belts: on the central tunnel and on side rails.

Furthermore, all three attachment points can be used for the installation of lap and diagonal harness.

Safety belts

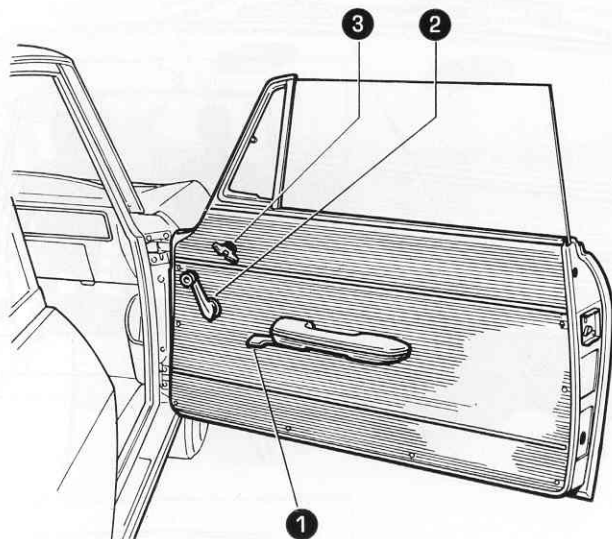

- 1 Lever to actuate (downward) and release the safety device (both doors). Both doors have locks for closing from the outside. To close, turn the key in the direction of travel (the key can be withdrawn only when it is vertical).
- 2 Window regulator handle.
- 3 Vent window control.

How to use your car

ENGINE BONNET
LUGGAGE BOOT

To open

- The bonnet opens opposite travel direction; to release the catch, pull the lever under the dashboard.
- To hold the bonnet in open position, place the rod 1 as shown in the illustration.

Illumination of the engine.

- The illumination of the engine compartment is effected by a light fixed under the bonnet. It operates automatically when the bonnet is raised and the external lights are on.

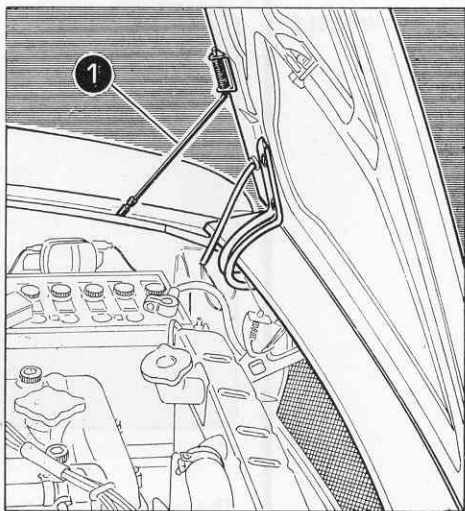

To open the boot lid lift the lever situated on the door jamb on the L.H. side. The lock utilises the same key as the doors.

Under the mat of the boot:

- Spare wheel

On R.H. side of boot:

- Jack
- Tool kit

TOOL KIT

- Wheel brace
- Pliers
- Box spanner for plugs
- Tommy bar for plug spanner
- Phillips screwdriver
- Screwdriver

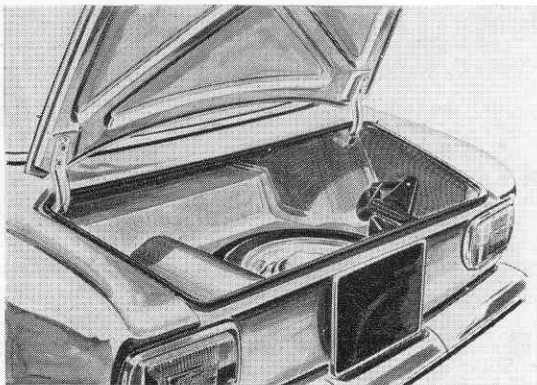

To open

Equipment

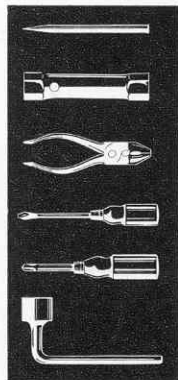



How to use your car

WHEELS

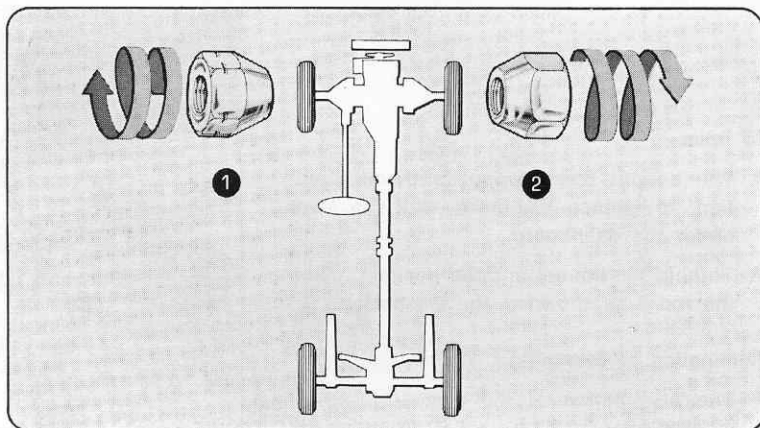

The wheels are of the pressed steel type.

Wheel removal



- Remove wheel cover and slacken wheel nuts by one turn with the wheelbrace.
 - ① left-hand wheels: turn the nuts **clockwise** to unscrew
 - ② right-hand wheels: turn the nuts **anti-clockwise** to unscrew.
- Raise the car by inserting the jack arm in the special socket on the underside of the body longitudinal member. Before operating the jack, apply the handbrake.
- Fully unscrew the nuts and remove the wheel.

Reinstallation

- Tighten the nuts carefully in diagonal order. Check again tightness of nuts after lowering the jack.
 - ① left-hand wheels: turn the nuts **anti-clockwise** to screw in
 - ② right-hand wheels: turn the nuts **clockwise** to screw in.

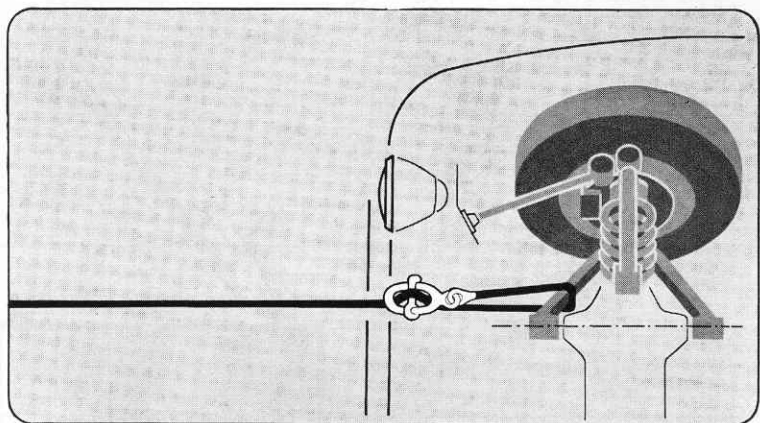

When taking a tow, secure the rope exclusively to the front suspension lower wishbone in correspondence of wishbone attachment to body.

Take A tow

When taking another vehicle in tow, secure the rope to the axle tube making certain not to damage the pipes of hydraulic brakes.

Take IN tow

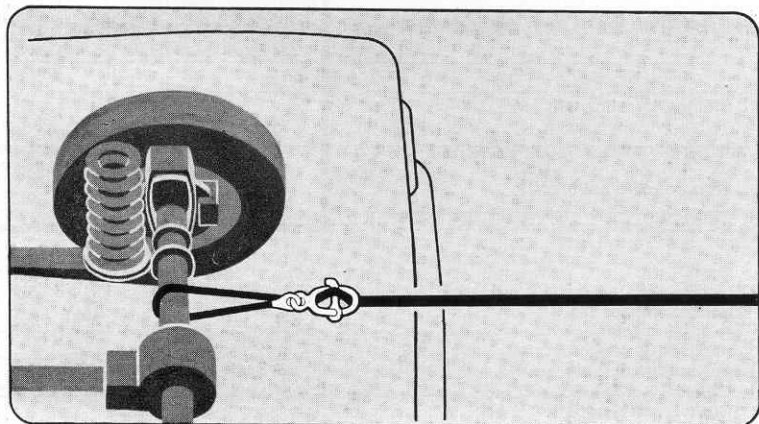

LUBRICATION

at the first

450-750 mi.
(700/1200 Km)

— Carry out the **Coupon A** from the Service Coupon Book.

3100-3750 mi.
(5/6000 Km)

— Carry out the **Coupon B** from the Service Coupon Book.

EVERY
300 mi.
(500 Km)

1

Check level of engine oil and top up if necessary.

When checking push the dipstick all the way down. Never allow the oil to fall below the minimum or to exceed the maximum level while topping up.

2

Check level of gearbox oil and top up if necessary.

3

Check level of differential oil and top up if necessary.

4

Check level of steering box oil and top up if necessary.

EVERY
3750 mi.
(6000 Km)

5

Change engine oil (or every 6 months whichever comes first). When topping up never exceed the maximum level.

6

Change oil filter element.

7

Grease ignition distributor.

8

Grease propeller shaft sliding yoke.

9

Change gearbox oil.

EVERY
11,250 mi.
(18,000 Km)

10

Change differential oil.

OCCASIONALLY

Grease the linkage joints & hinges of:

- carburettors
- clutch & service brake
- handbrake
- doors & lids

Grease flexible shafts.

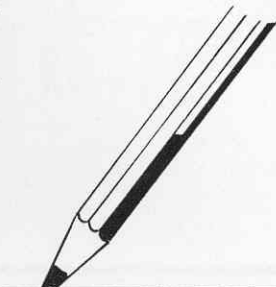

<input checked="" type="checkbox"/>	<input type="checkbox"/>	<input type="checkbox"/>	<input type="checkbox"/>	<input type="checkbox"/>	<input type="checkbox"/>	<input type="checkbox"/>	<input type="checkbox"/>	<input type="checkbox"/>	<input type="checkbox"/>
<input type="checkbox"/>	<input type="checkbox"/>	<input type="checkbox"/>	<input type="checkbox"/>	<input type="checkbox"/>	<input type="checkbox"/>	<input type="checkbox"/>	<input type="checkbox"/>	<input type="checkbox"/>	<input type="checkbox"/>
<input type="checkbox"/>	<input type="checkbox"/>	<input type="checkbox"/>	<input type="checkbox"/>	<input type="checkbox"/>	<input type="checkbox"/>	<input type="checkbox"/>	<input type="checkbox"/>	<input type="checkbox"/>	<input type="checkbox"/>
<input type="checkbox"/>	<input type="checkbox"/>	<input type="checkbox"/>	<input type="checkbox"/>	<input type="checkbox"/>	<input type="checkbox"/>	<input type="checkbox"/>	<input type="checkbox"/>	<input type="checkbox"/>	<input type="checkbox"/>
<input type="checkbox"/>	<input type="checkbox"/>	<input type="checkbox"/>	<input type="checkbox"/>	<input type="checkbox"/>	<input type="checkbox"/>	<input type="checkbox"/>	<input type="checkbox"/>	<input type="checkbox"/>	<input type="checkbox"/>
<input type="checkbox"/>	<input type="checkbox"/>	<input type="checkbox"/>	<input type="checkbox"/>	<input type="checkbox"/>	<input type="checkbox"/>	<input type="checkbox"/>	<input type="checkbox"/>	<input type="checkbox"/>	<input type="checkbox"/>
<input type="checkbox"/>	<input type="checkbox"/>	<input type="checkbox"/>	<input type="checkbox"/>	<input type="checkbox"/>	<input type="checkbox"/>	<input type="checkbox"/>	<input type="checkbox"/>	<input type="checkbox"/>	<input type="checkbox"/>
<input type="checkbox"/>	<input type="checkbox"/>	<input type="checkbox"/>	<input type="checkbox"/>	<input type="checkbox"/>	<input type="checkbox"/>	<input type="checkbox"/>	<input type="checkbox"/>	<input type="checkbox"/>	<input type="checkbox"/>
<input type="checkbox"/>	<input type="checkbox"/>	<input type="checkbox"/>	<input type="checkbox"/>	<input type="checkbox"/>	<input type="checkbox"/>	<input type="checkbox"/>	<input type="checkbox"/>	<input type="checkbox"/>	<input type="checkbox"/>
<input type="checkbox"/>	<input type="checkbox"/>	<input type="checkbox"/>	<input type="checkbox"/>	<input type="checkbox"/>	<input type="checkbox"/>	<input type="checkbox"/>	<input type="checkbox"/>	<input type="checkbox"/>	<input type="checkbox"/>

7,500
12,000 Km.
11,250
18,000 Km.
15,000
24,000 Km.
18,750
30,000 Km.
22,500
36,000 Km.
26,250
42,000 Km.
30,000
48,000 Km.

MILEAGE COVERED

TICK EACH ITEM AT THE RESPECTIVE MILEAGE

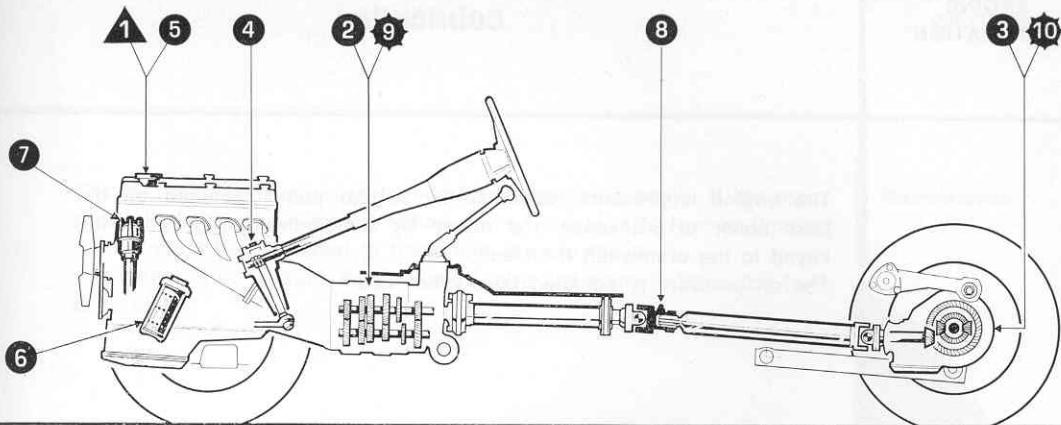

LUBRICANTS

PART	Grade	Commercial equivalents		
		AGIP	Esso	Shell
Engine	API MS SAE 20 W/40	AGIP F.1 Woom SAE 20 W/50	UNIFLO Motor Oil	SHELL Super Motor Oil « 100 »
Gearbox Steering box and differential	API EP SAE 90	AGIP F.1 Rotra Hypoid SAE 90	ESSO Gear Oil GX 90	SHELL Spirax 90 EP
Propeller shaft sliding yoke	NLGI 1	AGIP F. 1 Grease 15	ESSO Multi-purpose Grease H	SHELL Retinax G
Front wheel bearings (see maintenance schedule)	NLGI 2/3	AGIP F.1 Grease 33 FD	ESSO Norva 275	SHELL Retinax AX

SAE - Society of Automotive Engineers
 API - American Petroleum Institute
 NLGI - National Lubricating Grease Institute

In countries where the above mentioned lubricants are not available, it is possible to replace them with products of other leading makes provided that in accordance with the grades given in the table.

The engine is pressure lubricated by a gear pump mounted on the front cover of crankcase and driven by a spindle through a pinion keyed to the crankshaft front end.

The oil pressure is adjusted by a relief valve.

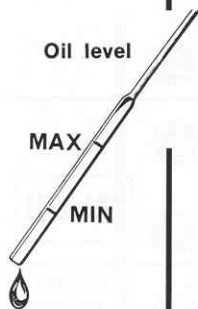

When checking push the dipstick all the way down. Never allow the oil to fall below the minimum or, while topping up, to exceed the maximum level.

**Oil change
(engine warmed up)**

With the engine stopped, drain off old oil thoroughly.
Remove the filter body and clean the inside of it.
Replace the filter element.
Refill with new oil.

**Oil replacement
after reconditioning**

With a reconditioned engine follow the instructions given for the **running in period**.

Lubrication

OIL PUMP

The oil pressure is adjusted by a valve in the pump body. **If the pressure falls below the minimum values**, an authorized Alfa Romeo Service Station must be consulted to trace and remedy the fault. Lubricating circuit faults are indicated by a red warning light, too (see page 8).

Maintenance

Oil pressures with hot engine			
Engine running fast	min. 50 psi	3.5	Kg/cm ²
	max. 65-70 psi	4.5-5	Kg/cm ²
Engine idling	min. 7-14 psi	.5-1	Kg/cm ²



Maintenance

To remove impurities the engine oil is filtered by a full-flow filter in series with the delivery circuit. The filter is fitted with a valve that bypasses the element if it should become clogged.

When replacing the filter element thoroughly clean the case.

It should be remembered that the periodical replacement of the element, perfect cleaning and careful assembly of the filter are essential for best engine performance.

On reassembling the filter, always replace the seal with a new one.

After refitting the filter to the engine, make sure that there are no oil leaks.

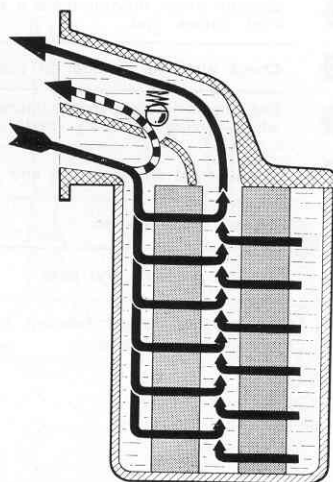

OIL FILTER

 Oil flow with normal operation

 Oil flow in an emergency

AT THE FIRST

450-750 mi.
700/1200 Km
3100-3750 mi.
5/6000 Km

- Coupon A from the Service Coupon Book.
- Coupon B from the Service Coupon Book.

EVERY
300 mi.
500 Km

- 1
- 2

- Check tyre inflation pressures.
- Check radiator water level.

- 3
- 4

- Clean air filter element (more frequently when driving on dusty roads usually).
- Check battery electrolyte level.

- 5
- 6

- Check tension of generator & fan driving belt.
- Check timing chain tension.

- 7
- 8

- Check contact-breaker point gap. Check timing.
- Clean wire gauze of crankcase ventilation system.

- 9
- 10

- Check brake pads.
- Clean carburettor strainers & jets.

- 11
- 12

- Check spark plugs.
- Check level of fluid in brake & clutch reservoir.

- 13
- 14

- Check clutch pedal free travel.
- Check valve clearances and adjust, if necessary.

-
- 15

- Check hoses of cooling circuit and heating system and replace, if necessary.
- Change brake fluid-or once a year whichever comes first.

- 16
- 17

- Check steering linkage for play.
- Replace air filter element (more frequently when driving on dusty roads usually).

- 18
-

- Check front wheel toe-in and caster.
- Inspect brake system.

-
- 19

- Tighten all bolts and nuts.
- Adjust front wheel bearing clearance & repack with grease.

EVERY
3750 mi.
6000 Km

EVERY
7,500 mi.
12,000 Km

EVERY
11,250 mi.
18,000 Km

EVERY
15,000 mi.
24,000 Km

EVERY
22,500 mi.
36,000 Km

EVERY
30,000 mi.
48,000 Km

7,500 Km
12,000 Km
11,250 Km
18,000 Km
15,000 Km
24,000 Km
18,000 Km
30,000 Km
22,500 Km
36,000 Km
26,250 Km
42,000 Km
30,000 Km
48,000 Km

MILEAGE COVERED

TICK EACH ITEM AT THE RESPECTIVE MILEAGE

MAINTENANCE

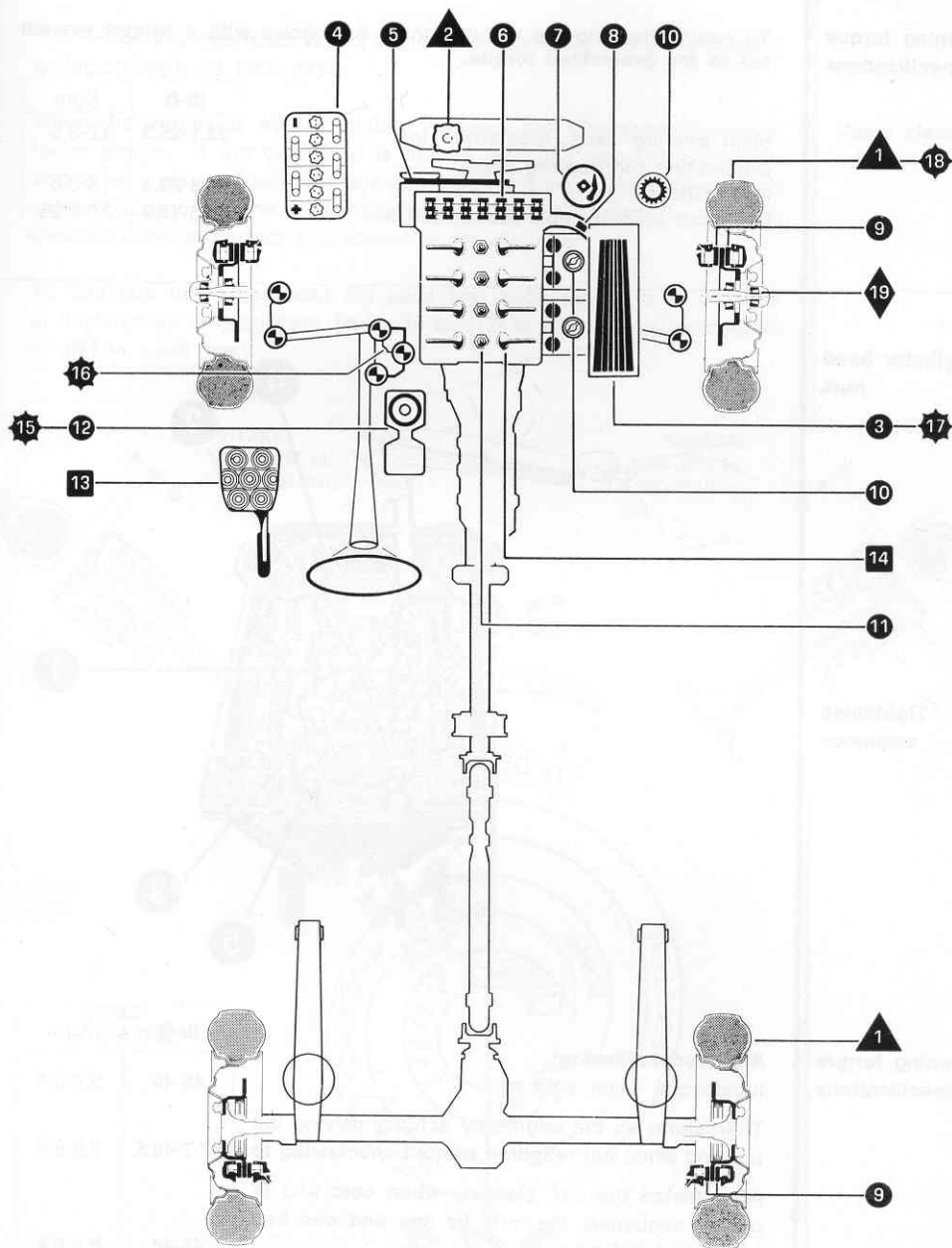

Tightening torque specifications

To avoid stressing the metal, tighten as follows **with a torque wrench set to the prescribed torque.**

Main bearing caps: lubetorque to . . .
 Connecting rod bearing caps:
 lubetorque to
 Camshaft journal caps: lubetorque to .

lb-ft	Kgm
23.1-25.3	3.2-3.5
24.6-26.3	3.4-3.6
14.5-15.9	2.0-2.25

Cylinder head nuts

Tightening sequence

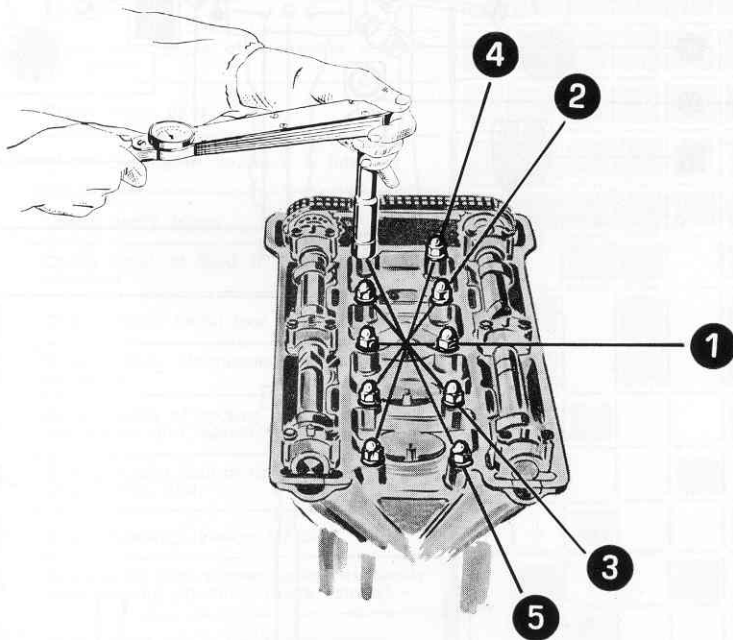

Tightening torque specifications

After reconditioning:
 lubetorque when cold to
 Then warm up the engine by actually driving the car and when hot **retighten without unscrewing to**
 After tested the car, slacken, **when cold** and in proper sequence, the nuts **by one and one half turn and lubetorque to**

lb-ft	Kgm
45-46	6.2-6.4
47.7-48.5	6.6-6.7
45-46	6.2-6.4

The V-mounted overhead valves are directly operated by two camshafts acting through oil bath cups.

When the engine is cold, carefully measure the clearance **G** with a feeler gauge. If the clearance is not as specified, remove camshafts and valve cups; measure the thickness **S** of the adjusting pad on each valve stem and replace it with another of proper thickness so that the clearance is the correct one shown in the diagram.

To facilitate this adjustment the pads are made available in a series of thicknesses ranging from **.05 to .14 in.** (1.3 to 3.5 mm.) in increments of **.001 in.** (.025 mm.).

Valve clearance adjustment

INTAKE
.0187-.0197 in.
 (.475-.500 mm)

EXHAUST
.0206-.0216 in.
 (.525-.550 mm)

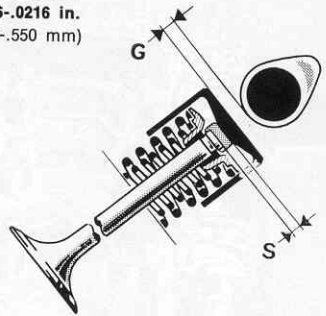
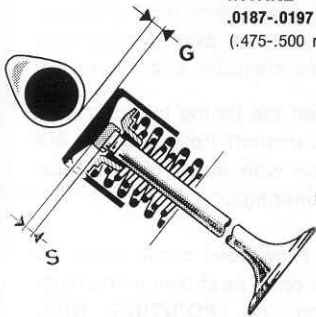

M
 MAXIMUM
 ADVANCE

F
 FIXED
 ADVANCE

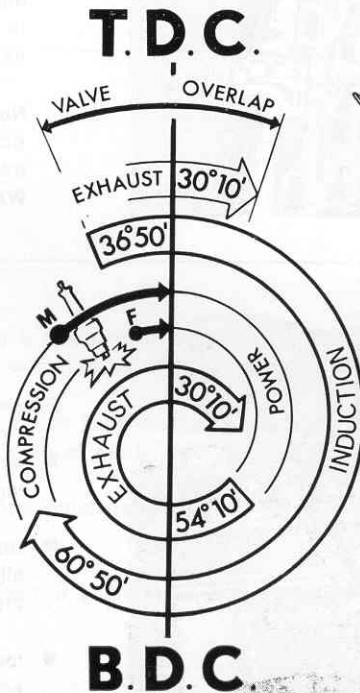

Checking the
timing

Top dead centre

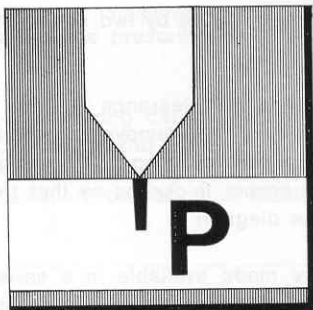

The valve timing is correct when:

- no. 1 piston on compression stroke, the timing mark cut in the crankshaft pulley and marked **P**, is in line with the reference plate and...

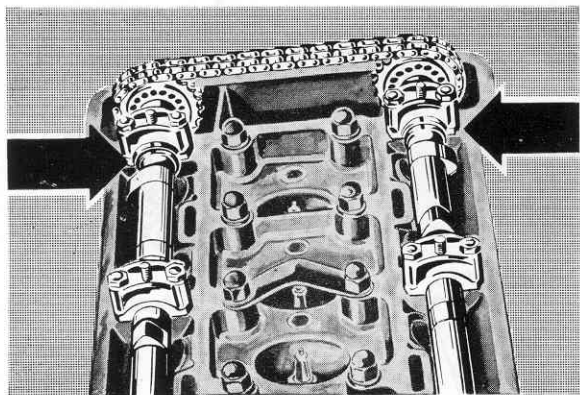

- ...when the timing marks cut on the camshaft front journals are in line with those on the journal bearings.

No. 1 cylinder cams must be positioned as shown in the illustration, i.e. **POINTING OUTWARD**.

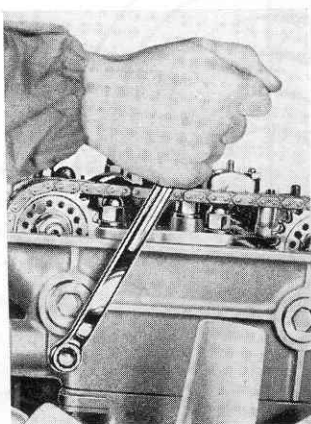
Chain tension
adjustment

Proceed as follows:

- slacken off the setscrew securing the chain tensioner;
- run engine at idling speed to allow the tensioner to tighten the chain;
- lock the chain tensioner setscrew firmly.

Air filter

Summer/winter adjustment

The control **L**, operated by hand, has two positions:

- upward (posit. 1) fresh air in summer
- downward (posit. 2) pre-heated air in winter.

Cleaning the filter element

Loosen the straps fastening the filter housing to the intake manifold. Remove the rear cover of the filter, withdraw the element and clean it carefully from inside with low pressure compressed air. Moreover at the prescribed intervals change the element.

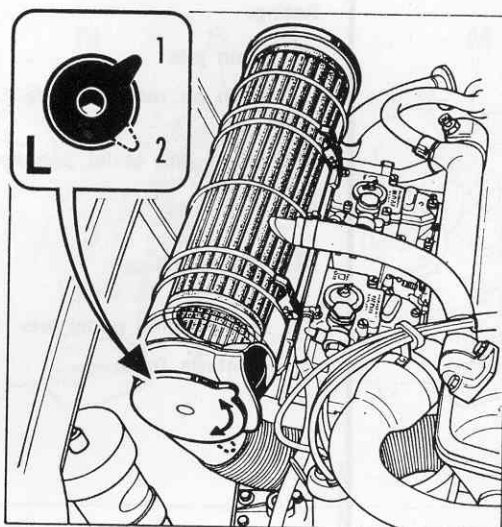

The fuel supply is effected by a mechanical pump located on the right-hand side of the engine and actuated by the distributor drive shaft.

The fuel sucked by the fuel pump reaches the carburettor through a bowl filter on the right-hand side of the engine compartment.

The filter incorporates a device which regulates the outlet pressure of the fuel.

At the prescribed intervals clean or change the filter element, if necessary.

Fuel pump and filter

Rating:

①	Main jets	112
	Main air restrictor jets	220
②	Idling jets (axial passage 150)	50 F11
	air restrictor jet	120
③	Choke jets	65 F5
④	Acceleration pump jets	35
	Venturis (mm)	28

2 CARBURETTORS
WEBER
 40 DCOE 28

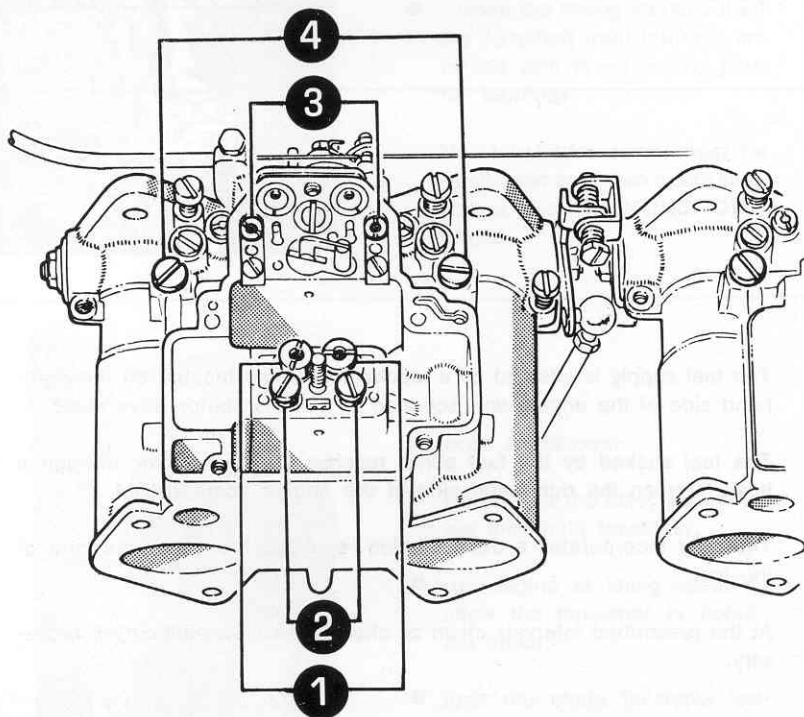

- F** Adjusting screw for minimum opening of throttle
- M** Idling mixture adjusting screw
- S** Screw for synchronizing throttles of the two carburetors
- T** Joint for control linkage (to pedal)

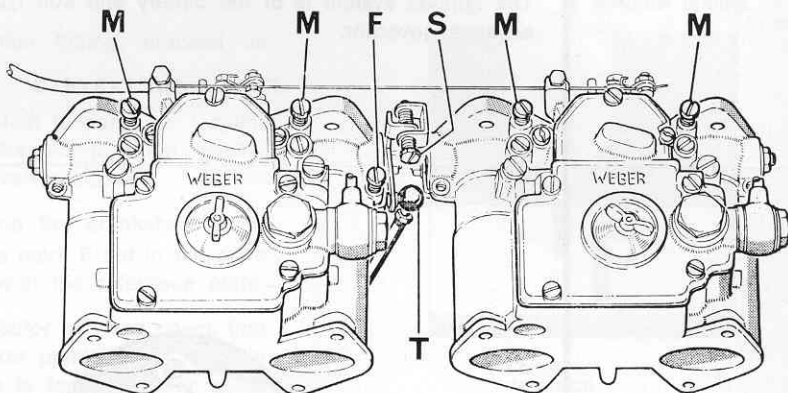

Check the ignition timing and inspect the electric system (spark plugs, distributor, coil etc.) for proper operation. Remove the air filter element and clean thoroughly. Check the flexible mounts between carburetors and intake manifold for tightness.

Preparatory steps

Detach the control linkage **T** from carburetors. Slacken the screws **F** and **S** almost fully. Operate the throttles a few times, making sure that there is no binding. Fully depress the throttle control lever of rear carburettor so that the throttles are fully closed; then screw in the screw **S** until contact is made.

Aligning the throttle valves

Back off the screws **M** **two turns** from closed position. Tighten the screw **F** to contact, then screw it in **one more turn** to ensure feeding to engine. Connect the control linkage **T** to carburetors. Start the engine and warm it up. If necessary, back off the screw **F** very slowly until the engine runs at about 600-700 r.p.m.

Idle

The ignition system is of the battery and coil type with a centrifugal advance governor.

Firing order: 1-3-4-2

Distributor

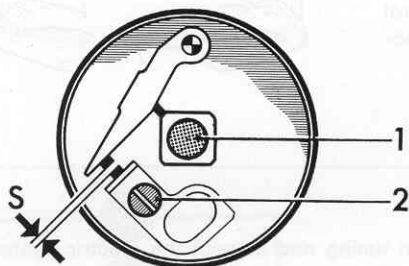

At the prescribed intervals:

Check with a feeler gauge the contact-breaker point gap:

S = .0138 to .0157 in. (.35-40 mm)

Adjust by means of screw **2** if necessary.

If contacts are burnt or pitted, they may be smoothed with a very fine file and then cleaned with petrol.

Soak the felt **1** with oil.

Check the inside of the distributor cap for any sign of moisture, carbon deposits or cracks. Check also the central power electrode for free movement in its seat, and that spring action is effective. At last, check the rotor arm for proper insulation and terminals on cap for good operating conditions.

Checking the ignition timing

To check the ignition timing, proceed as follows:

- 1 rotate the crankshaft to bring no. 1 cylinder piston to the compression stroke, that is with both valves closed;
- 2 by slightly rotating the crankshaft, bring the fixed advance mark **F** cut in the drive pulley into line with the reference plate;
- 3 remove the distributor cap and check that the contact-breaker points begin to open when the engine is turned further in its normal direction of rotation.

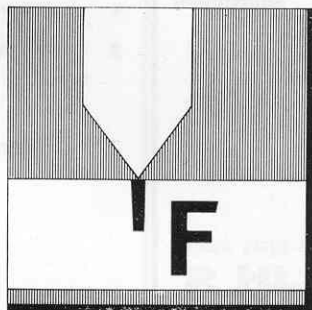

FIXED
ADVANCE
 $2^{\circ}/4^{\circ}$ BTDC

A more accurate check can be made with a **stroboscopic gun** as follows:

- run the engine at about 4,600 rpm and direct the light from the stroboscopic gun onto the pulley;
- if the timing is correct, the **M** (max. advance) stamped on the pulley will be seen in line with the reference plate;
- if it is found that the max. advance is greater or less than the prescribed value, adjust the fixed advance accordingly, as it is better to have correct timing at high speeds.

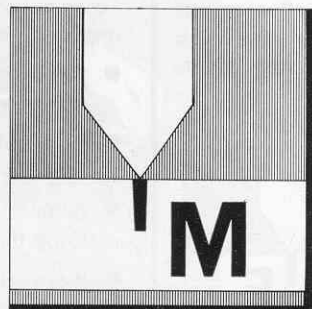

MAX.
ADVANCE
 $37^{\circ}/40^{\circ}$ BTDC
at 4600 rpm

Timing adjustment

If the timing requires adjustment proceed as follows:

- 1 unscrew the nut on the bolt securing the distributor body;
- 2 rotate the distributor body anti-clockwise or clockwise according to whether it is necessary to advance (**A**) or to retard (**P**) the ignition setting;
- 3 retighten the nut, taking care not to move the distributor body.

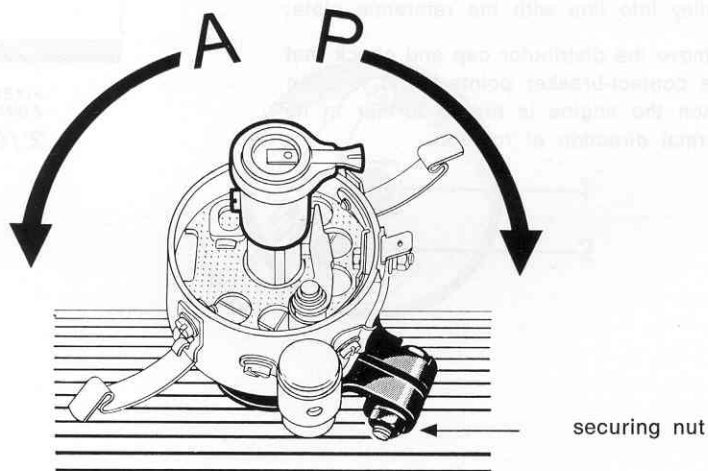

Timing after removal of distributor from engine

To re-set the timing after the distributor has been removed from the engine proceed as follows:

- rotate the crankshaft to bring No. 1 piston to the compression stroke, that is with both valves closed;
- by slightly rotating the crankshaft, bring the fixed advance mark **F** into line with the reference plate;
- remove the distributor cap and rotate the drive shaft by hand to bring the rotor arm in line with the contact for No. 1 cylinder.
- make sure that in this position the contact-breaker points are about to open;
- then without disturbing the drive shaft, mount the distributor on its bracket and tighten the distributor bracket bolt.
- check the ignition timing as described in the previous page.

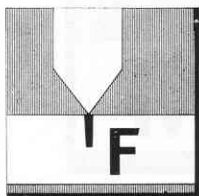

The spark plugs are of the type with four points and a central electrode. The only maintenance required is occasional cleaning with a brush of the central and earth electrodes.

No routine adjustment is necessary of the gap between the electrode and points.

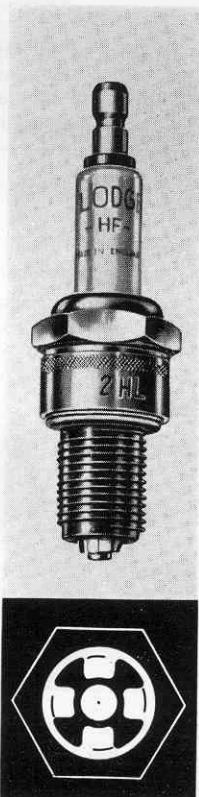

Spark plugs LODGE
2 HL

The spark plugs should be tightened when cold to a torque of **18-25.3 lb-ft** (2.5-3.5 kgm); lubricate the threads with graphite grease before fitting.

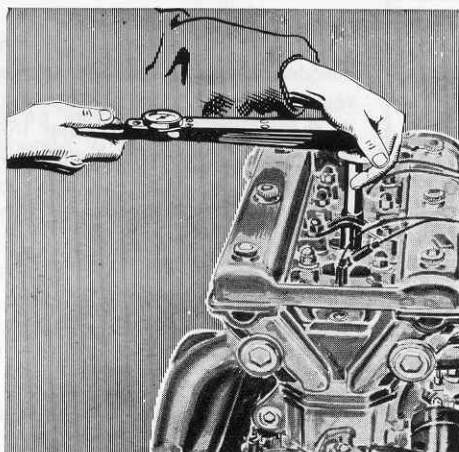

Water pump

Engine cooling is assured by forced water circulation, by means of a centrifugal pump.

The water pump built into the fan bracket is driven by the belt which drives both the fan and the generator.

Cooling circuit

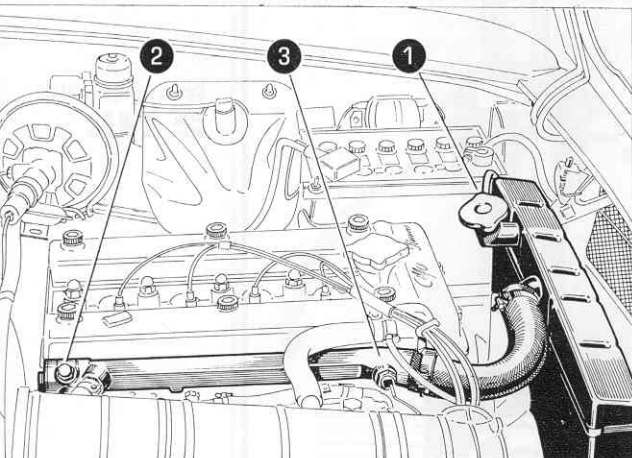

- 1 Radiator cap
- 2 Air bleed screw
- 3 Thermostat

The thermostat is fitted in the water outlet hose between the cylinder head and the radiator.

To ensure the rapid warming-up of the engine, the thermostat must not open until the water has reached the prescribed temperature of **180°-189 °F (82°-87 °C)**.

As it is possible for the water to reach a temperature of **212°-221 °F (100°-105 °C)** the cooling system including the radiator is under pressure.

Should excessive water consumption occur, make sure that there are no leaks from the rubber hoses: also check the radiator cap, and make sure that the spring, the rubber seal and the valve are in good order. In case of doubt replace the cap.

Cleaning the system

To ensure the efficient operation of the cooling system, it is recommended that the radiator and engine be flushed out periodically to remove scale and other deposits. Proceed as follows:

- thoroughly drain off water from the engine and radiator;
- fill the engine and radiator with a solution of about 1.8 Imp. gals (8 litres) of water and 10.6 ozs (300 gr.) of sodium bicarbonate;
- run the engine slowly for 10-15 minutes;
- drain off the solution;
- allow the engine to cool down and then circulate running water while leaving the drain plug and cock open;
- refill the engine and radiator with water and run the engine slowly for a few minutes;
- drain the circuit once more.

It is advisable to flush the cooling circuit as described above before adding antifreeze.

When refilling the cooling system after draining it thoroughly, the following procedure should be observed to ensure that the circuit is completely filled:

- loosen the air bleed screw in the cooling circuit (14 mm - 9/16" hex. wrench);
- check that the heating system is in operation making sure that the TEMPERATURE control lever is in the 3A position (see page 16);
- fill the cooling system with water, making sure that all the air is bled from the bleed screw from which water should appear;
- retighten the bleed screw;
- return the TEMPERATURE control lever to the 3C position.

Refilling the system

If the tension is insufficient, the belt will slip and wear prematurely; furthermore:

the cooling action will be affected because of the reduced speed of the fan and water pump;

the battery charging current will be reduced owing to the slower generator speed.

If the tension is excessive, the generator and water pump bearings will be overloaded with the consequent risk of damage.

Therefore it is necessary to check the belt tension at the prescribed intervals.

Adjusting the tension of fan, water pump and generator driving belt

The tension is correct when on pressing the belt down the amount of play is approximately $\frac{1}{2}$ in.

To tighten the belt unscrew the nut on the adjusting arm pivot pin, the nut of the securing bolt and move the generator outwards.

Carefully retighten the nuts after adjusting the belt tension.

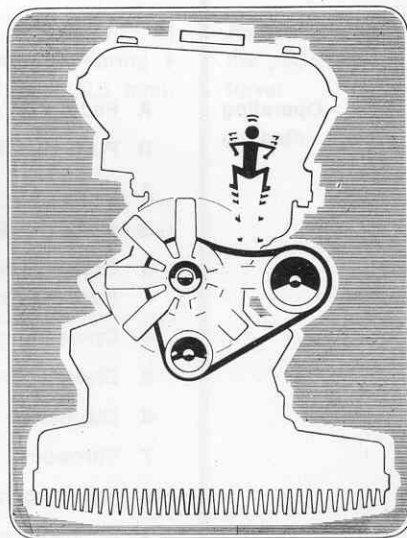

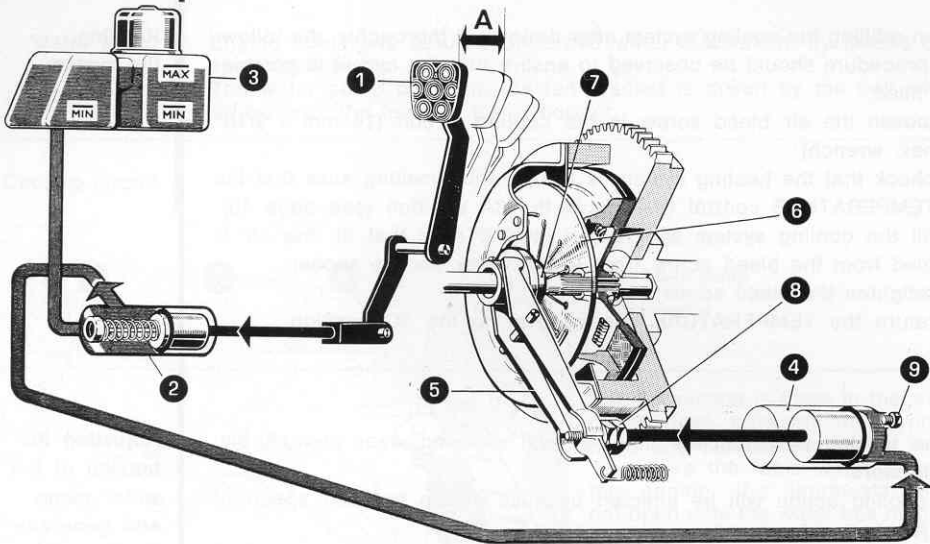

Operating diagram

- A Pedal free travel
- B Push rod free travel
- 1 Pedal
- 2 Master cylinder
- 3 Clutch & brake fluid reservoir
- 4 Operating cylinder
- 5 Disengagement lever
- 6 Diaphragm spring
- 7 Throwout bearing
- 8 Adjusting nuts
- 9 Air bleed screw.

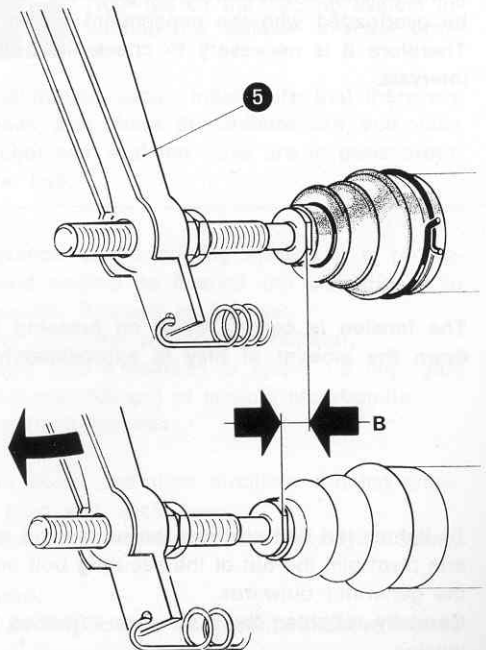

The clutch is of the hydraulically-operated single-plate dry type. The clutch pedal acts on a master cylinder supplied with the same type of fluid as the brake system.

When the clutch pedal is depressed the fluid under pressure actuates the piston in the cylinder **4** connected to the clutch disengagement lever **5**.

The pressure plate is controlled by means of diaphragm spring **6**.

The clutch pedal free travel A should be about 1 $\frac{1}{4}$ in. (30-32 mm.).

When, owing to wear on the clutch disc facing, the pedal free travel is reduced to $\frac{3}{4}$ in. (17-19 mm) the free travel must be restored.

Measure with a rule the free travel **B** at the end of push rod of cylinder **4**, depressing the clutch pedal until the throwout bearing **7** contacts the spring **6**; the travel **B** should be **.08-.10 in.** (2-2.5 mm).

If the travel is shorter, act on adjusting nuts **8**.

At the same time make sure that, by pressing the pedal as far as it will go, the push rod of cylinder **4** can move through a total travel of **.53-.56 in.** (13.5 - 14.2 mm).

If any component of the system has been removed, thoroughly bleed the circuit.

**Adjusting
the pedal free
travel**

Transmission ratios

1st	3.30 : 1
2nd	1.99 : 1
3rd	1.35 : 1
4th	1.00 : 1
5th	.86 : 1
Rev.	3.01 : 1

The gearbox has 5 synchromesh forward gears and one reverse.
The gear lever is floor mounted.

RM = Reverse
S = Synchromesh
F = Neutral

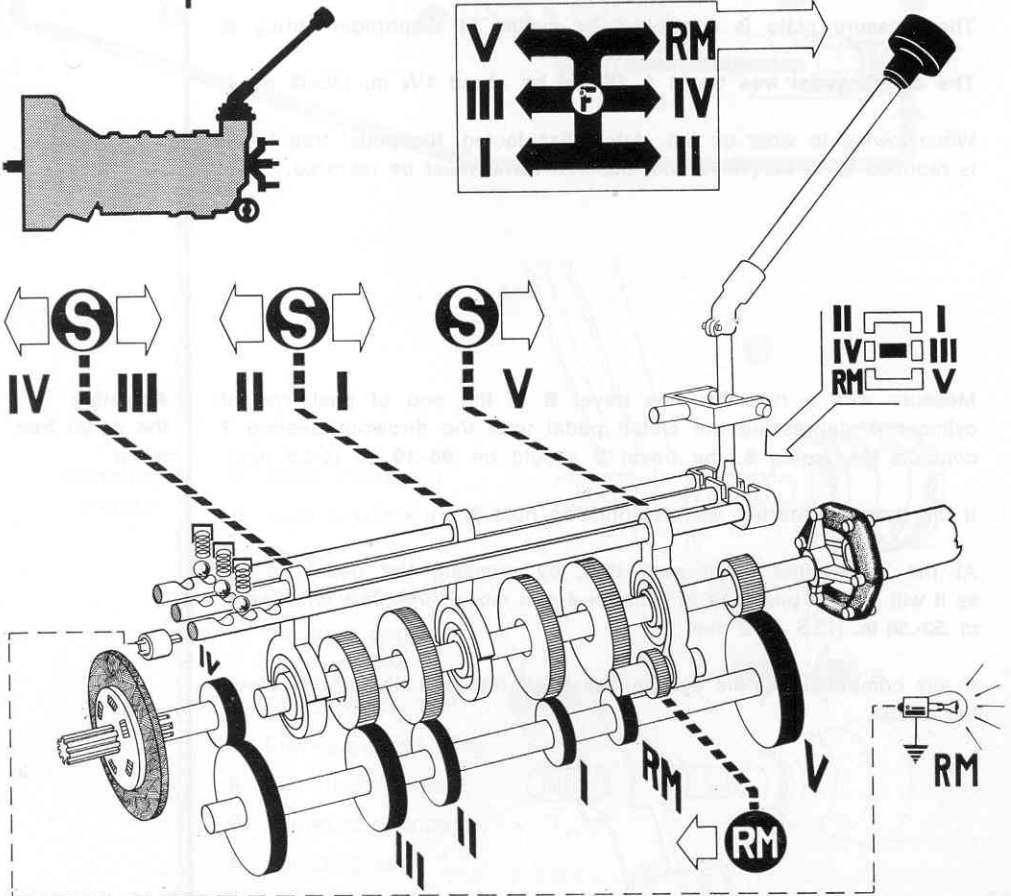

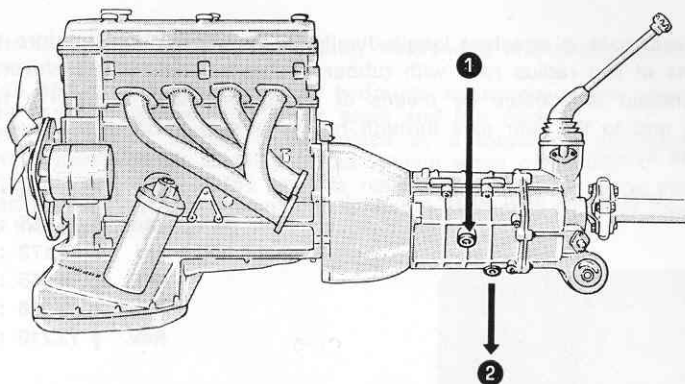

Any inspection or adjustment of the gearbox must be done only by an **authorized Alfa Romeo Service Station**.

1 Filler plug.

Check that gearbox is full of oil to the bottom edge of the filler orifice.

2 Drain plug.

The propeller shaft is in two sections and has an intermediate flexible support attached to the body.

The front section is provided with a rubber coupling at the gearbox end; a universal joint is provided at each end of the rear section.

PROPELLER SHAFT

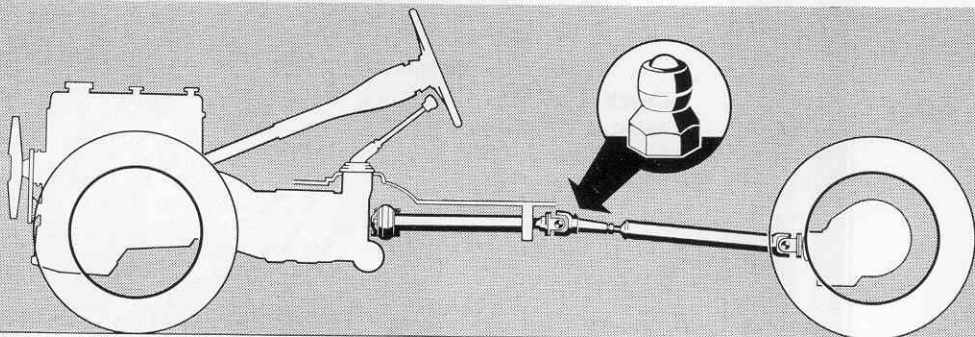

Grease the sliding yoke at the scheduled intervals.

The rear axle is attached longitudinally to the supporting structure by means of two radius rods with rubber bushes at the ends; transverse attachment is effected by means of an upper T-arm hinged to the body and to the rear axle through rubber bushes. The final drive is of the hypoid type.

Overall ratios

with 41 : 9 final drive

1st	15.049 : 1
2nd	9.055 : 1
3rd	6.172 : 1
4th	4.555 : 1
5th	3.918 : 1
Rev.	13.710 : 1

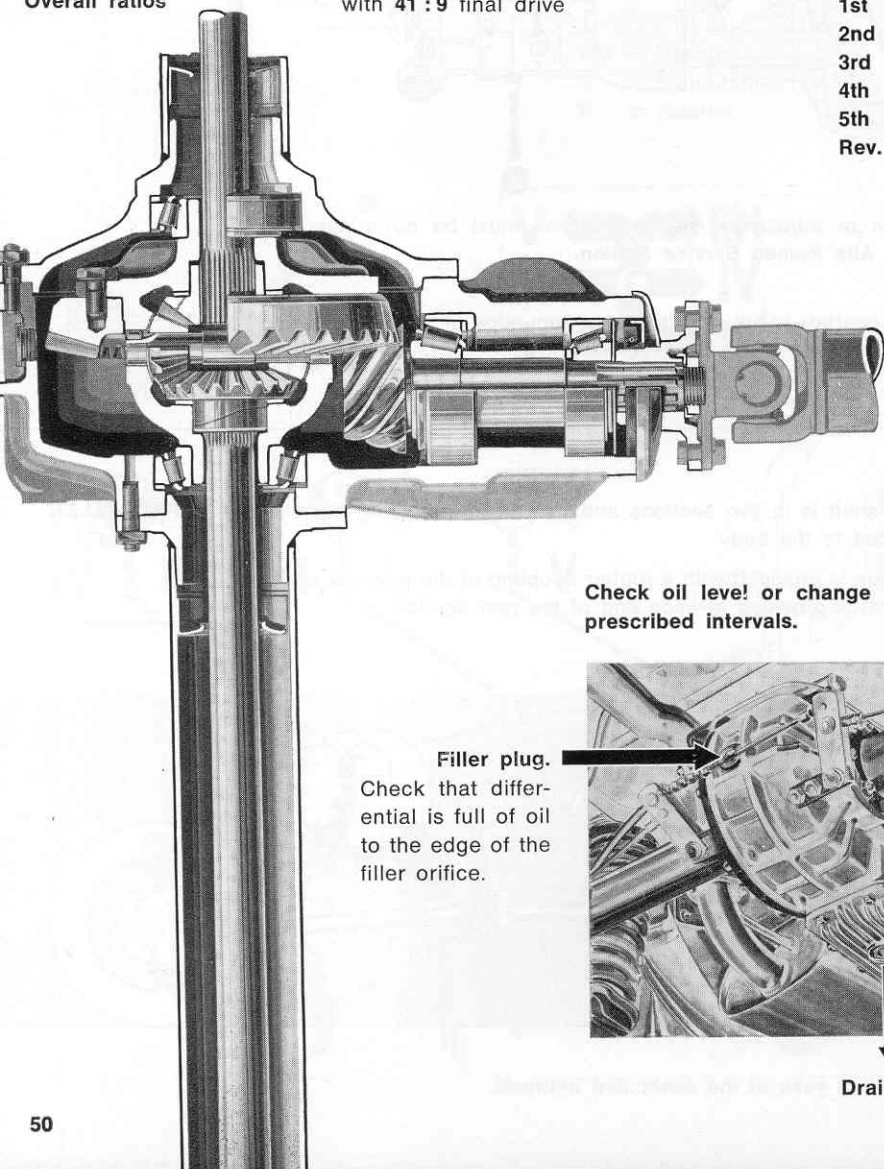

Check oil level! or change the oil at the prescribed intervals.

Filler plug.
Check that differential is full of oil to the edge of the filler orifice.

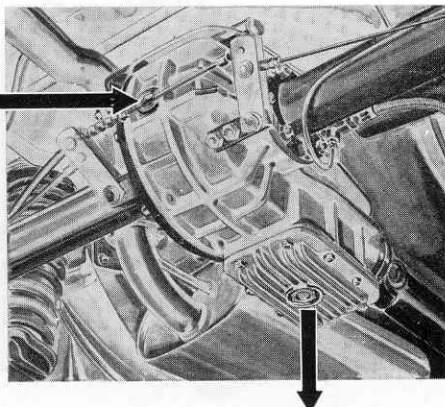

Drain plug

The front wheels are independently suspended and connected to the body by transverse arms. Coil springs and double-acting hydraulic telescopic shock absorbers are located between the lower arms and the body. The suspension system is completed by a transverse stabilizer rod which improves the stability of the vehicle when cornering. Upward movement of the arms is restricted by bumper pads situated near the springs. Downward movement is restricted by pads attached to the cross member.

Suspension components require no regular lubrication. Whenever the damping action of the shock absorbers is uneven, have them checked by an authorized Service Station.

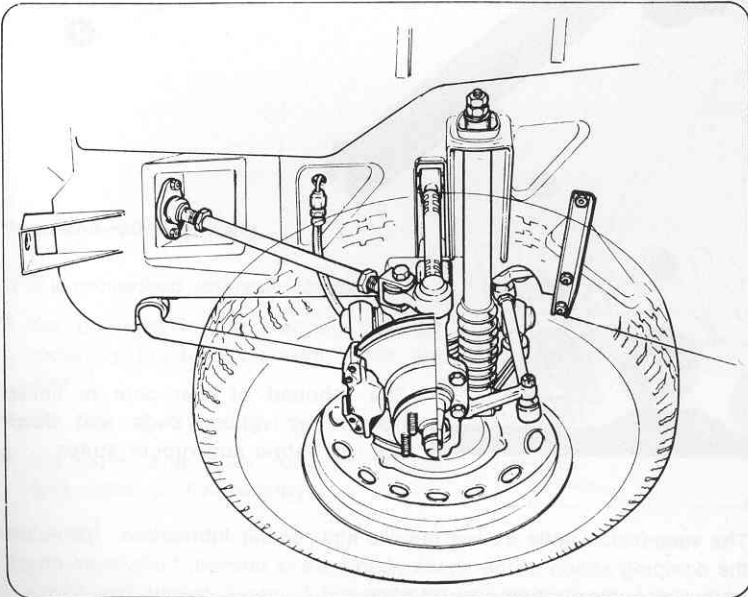
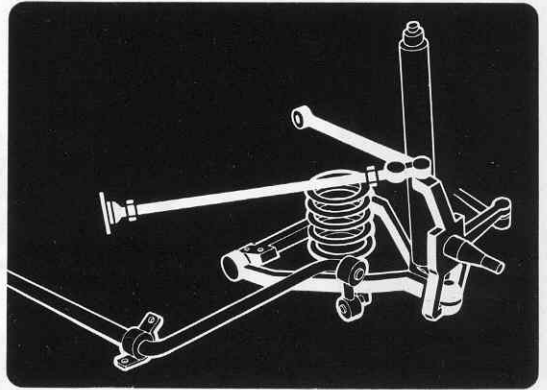

The rear suspension consists of coil springs and large diameter telescopic shock absorbers coaxial with the springs. The suspension system is completed by a transverse stabilizer rod linked to the radius rods and the body.

- 1 Radius rod
- 2 T-arm
- 3 Stabilizer rod
- 4 Shock absorber
- 5 Rubber buffer and rebound strap

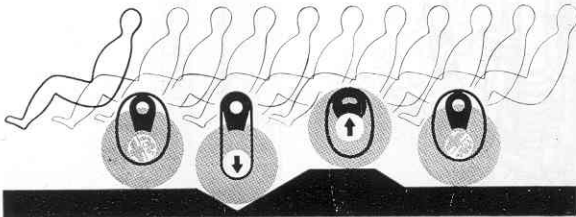
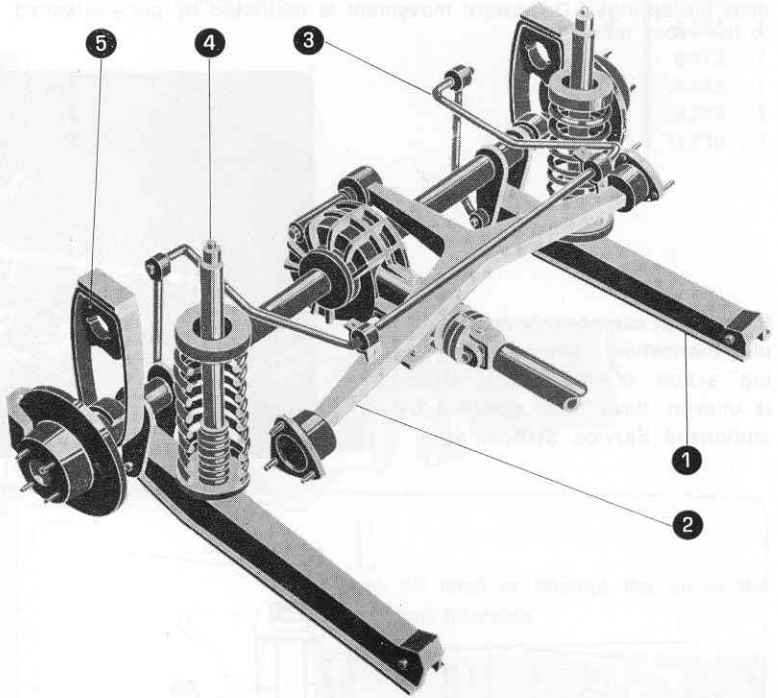

The rebound of rear axle is limited upward by rubber pads and downward by fabric and rubber straps.

The suspension units do not require any regular lubrication. Whenever the damping action of the shock absorbers is uneven, have them checked by an authorized Service Station.

This model is produced alternatively with steering of the worm and roller or recirculating ball type.

Recirculating ball steering.

At the prescribed intervals check:

- the oil level in the steering box (by removing the plug 1 shown in the figure);
- the steering linkage joints for play.

The steering of the recirculating ball type does not require any regular adjustment.

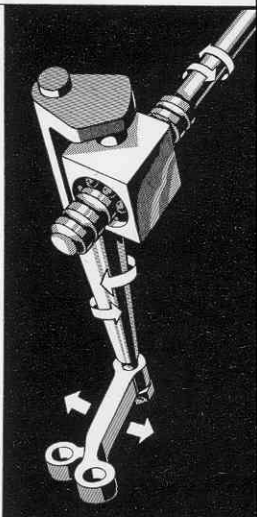
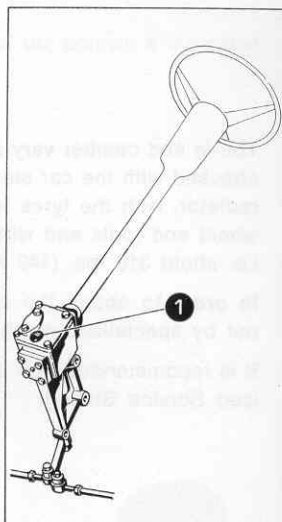

Worm-and-roller steering.

At the prescribed intervals check:

- the oil level in the steering box (by removing the plug 1 shown in the figure);
- the steering linkage joints for play;
- the worm and roller for play (adjust with screw 2, if necessary).

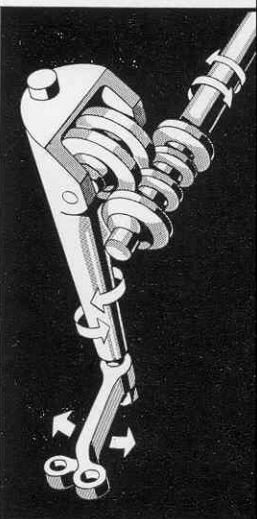
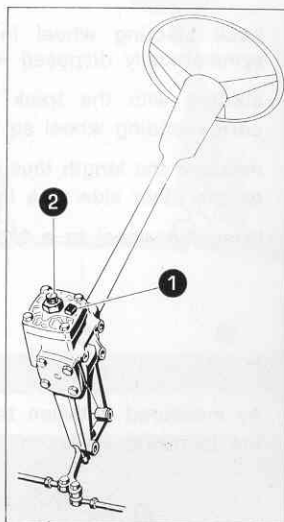

The ball and socket joints of the rods do not require any lubrication.

Toe-in
and camber

To avoid uneven and premature tyre wear, and to ensure positive and stable steering, front wheel toe-in and camber must be set to the prescribed values.

Toe-in and camber vary according to the car load: the values should be checked with the car standing on level ground, with full sump, tank and radiator, with the tyres inflated to the prescribed pressures, with spare wheel and tools and with a load corresponding to that of two persons, i.e. about 310 lbs. (140 Kg.).

In order to obtain the correct results these checks should be carried out by specialized mechanics using suitable equipment.

It is recommended that this operation should be entrusted to an authorized Service Station.

Toe-in
adjustment

Lock steering wheel in the central position, i.e. with the spokes symmetrically disposed in relation to the vertical;

starting with the track rod **1** on the steering box side, place the corresponding wheel so that the toe-in is $1/16''$ (1.5 mm);

measure the length thus obtained of the track rod and adjust the rod **2** on the other side to a length $3/16''$ (5 mm) shorter;

bring the wheel to a $1/16''$ toe-in by adjusting the centre track rod **3**.

Length of
track rods

As measured between ball joint centres, the length should fall within the following limits:

1 2 $10.71 \pm .3$ in.
(272 \pm 8 mm)

3 $21.26 \pm .4$ in.
(540 \pm 10 mm)

If these values cannot be restored, the cause will probably be attributable to distortion of the body resulting from a collision.

Chassis maintenance

FRONT WHEELS

Non-adjustable; check chassis and suspension arms for distortion, if necessary.

Camber

The turning circle may be adjusted by means of the screws 4 indicated in the diagram.

Turning circle

Camber B = A + .20" (+ 5 mm)
 - .04" (- 1 mm)

Toe-in C = D + .12" (+ 3 mm)

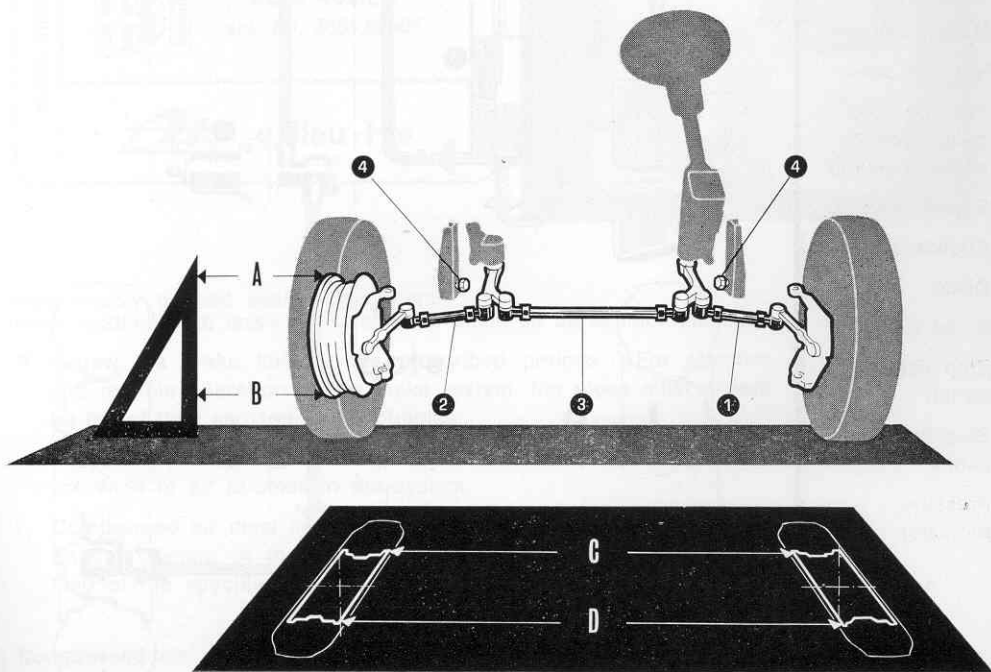



Chassis maintenance

Operating diagram

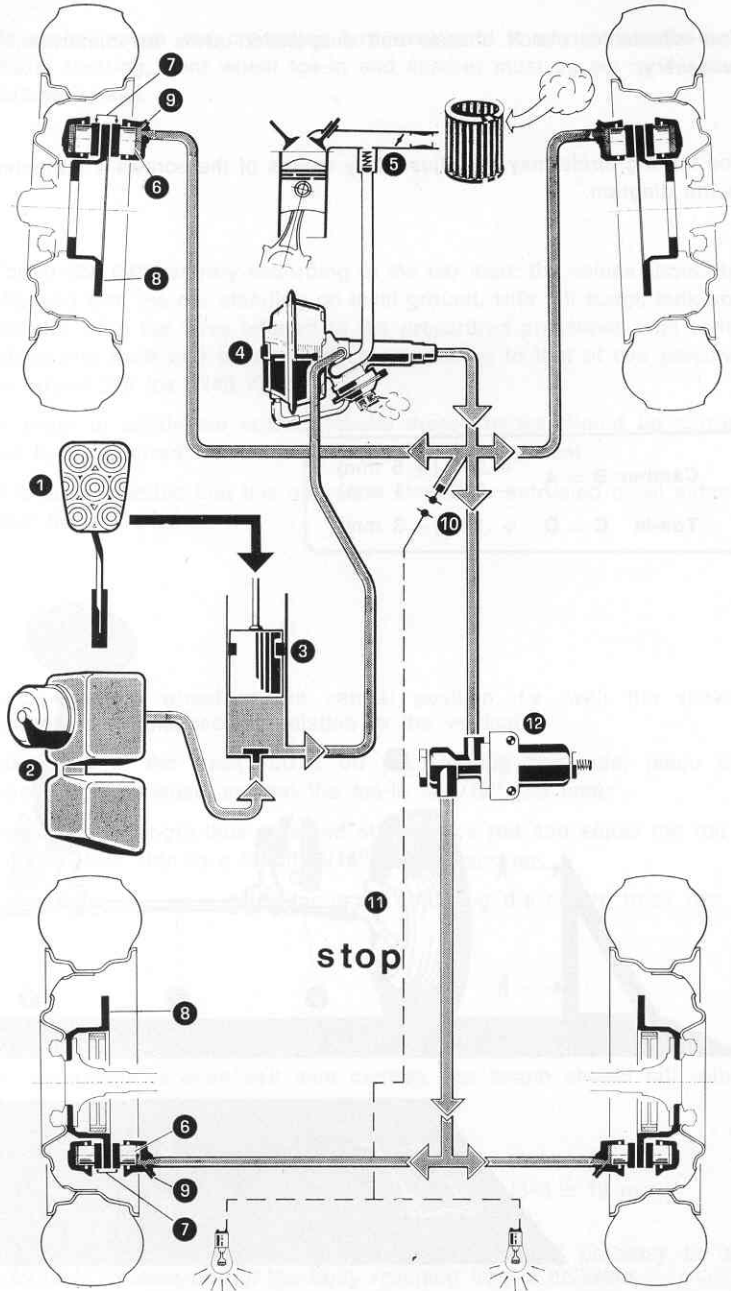

- 1 Brake pedal
- 2 Fluid reservoir
- 3 Master cylinder
- 4 Vacuum servo
- 5 Vacuum connection on intake manifold
- 6 Slave cylinders
- 7 Friction pads
- 8 Discs
- 9 Bleed screws
- 10 Stop light switch
- 11 Stop light cable
- 12 Pressure regulator

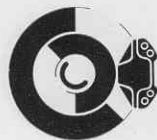

The **ATE** brake system consists of four caliper type disc brakes operated by a master cylinder. The friction pads of the front and rear brakes are directly actuated by the cylinders integral with the calipers.

The brakes are self-adjusting.

A pressure regulator controls the braking power to rear brakes.

Such a regulator shall not be tampered with; specifically, do not attempt to act on the adjusting nut as it is factory sealed.

To maintain the brakes in good operating condition, follow the servicing instructions given below:

- Take care to prevent the **minimum level** of fluid in the reservoir **from falling below** the **maximum level** by more than a quarter.
- For renewal or topping up, it is absolutely essential to use only

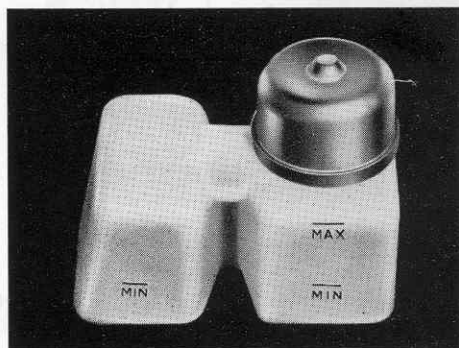

from freshly opened sealed containers.

When adding fluid, leave the strainer in place so as to filter the fluid.

- Renew the brake fluid at the prescribed periods. For effective and reliable operation of the brake system, the pipes must always be full of fluid and free of air bubbles.

Excessive and spongy brake pedal action is an indication of the presence of air bubbles in the system.

Compressed air must not be used for replenishing the system.

Should flushing of the brake circuit be required, use exclusively fluid of the specified type.

Compressed air or alcohol must on no account be used to dry a flushed system.

Hydraulic brake



Chassis maintenance

Rear

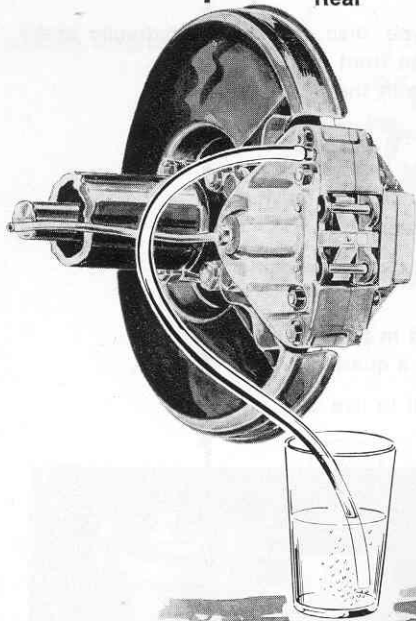

Front

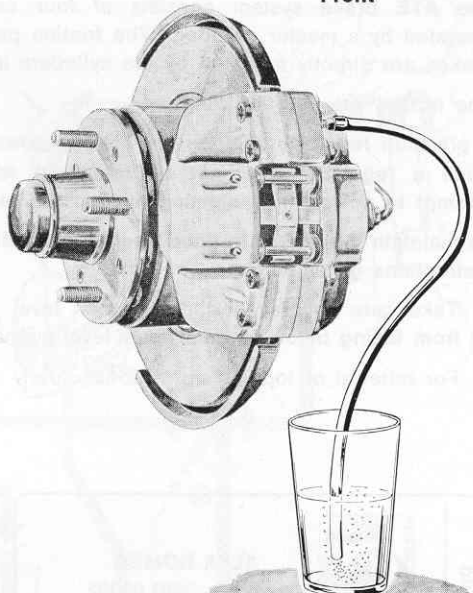

Air bleeding

Bleeding should be performed with the greatest care following these instructions:

- 1 Fill the reservoir, if necessary, with the genuine fluid freshly drawn from sealed containers; during bleeding operations pay attention that fluid level does not drop below the full by more than a quarter.
 - 2 Bleed starting from the rear calipers as follows:
Push a rubber pipe over the bleed screw; the other end will lead to a glass container half full of fluid.
Loosen the bleed screw.
Depress the brake pedal several times allowing it to return slowly until the pipe discharges fluid free from air bubbles.
Hold the pedal down and tighten the bleed screw.
- If the bleeding has been carefully performed, it will be found that when brake pedal is depressed, direct action on the fluid can be felt, free of resilience, immediately at the end of the free travel. If not, repeat the procedure.

Chassis maintenance



At the prescribed intervals check front & rear pads for wear. Proceed as follows:

- Jack up the car and remove the wheel
- drive the upper retaining pin out of caliper with a punch;
- remove the cross-shaped spring;
- drive out the lower retaining pin.

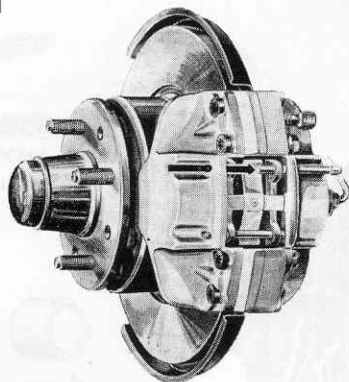

Friction pad inspection

Removal

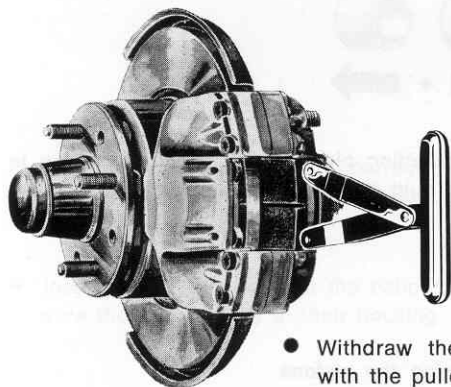
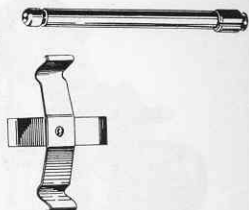

- Withdraw the pads with the puller A.2.0150

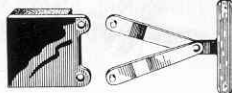

Thickness:
new
.6 in. (15 mm)

wear limit
.28 in. (7 mm)
REPLACE

- Check pad thickness.

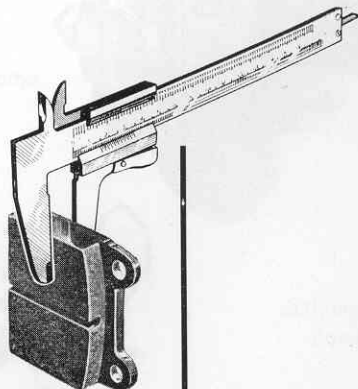

In case of uneven wear of pads, it is advisable to replace the whole set (front or rear).



Chassis maintenance

Pad reassembly

Clean the pad surface: never use mineral solvents or sharp-edged tools; check that dust excluder and retaining ring are sound; if not, replace them.

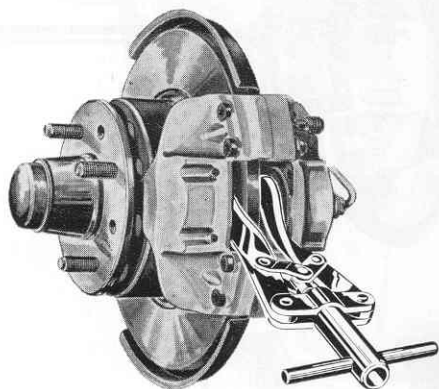

Press the pistons to the bottom of cylinders with the resetting tool **A.2.0147**; do not use chance tools which could damage the pistons or the disc.

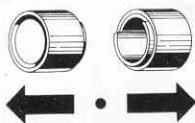

When resetting pistons care should be taken to prevent fluid overflow from the reservoir.

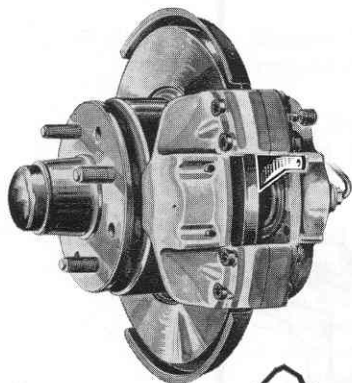

Positioning the pistons

Make sure the pistons are correctly positioned in the caliper by resting the template, **A.2.0149** for rear brakes and **A.2.0160** for front brakes, against the reference surface as shown.

- 1 Template
- 2 Piston

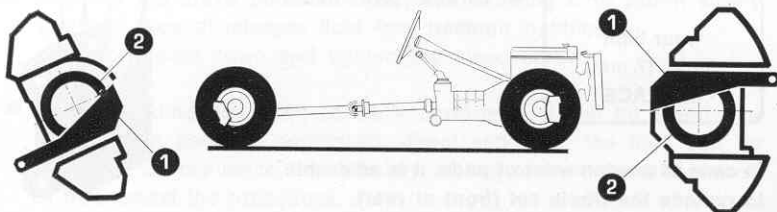



Pad reassembly (continued)

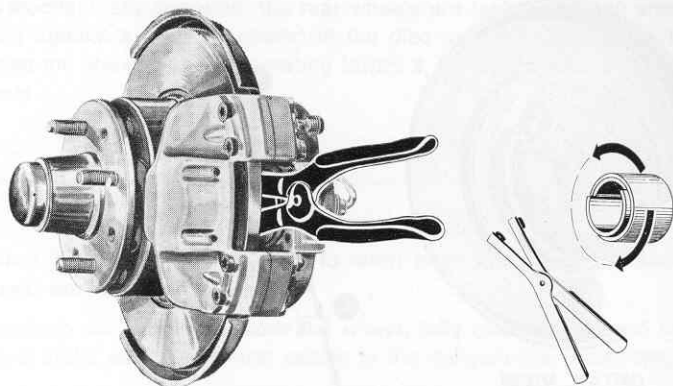

If the pistons are not in the correct position rotate them with the special pliers **A.2.0148/1** for rear brakes and **A.2.0159** for front brakes.

- Insert the friction pads in the caliper; if new pads are fitted, make sure they slide freely in their housing.
- Fit a retaining pin and then the cross-shaped spring; press down the free end of spring so that the other retaining pin can be fitted.
- With a suitable drift push the retaining pins fully home.

When refitting the pads, check the conditions of cross-shaped springs and upper & lower retaining pins and replace, if necessary; however, **these parts must be replaced whenever new pads are fitted.**



Chassis maintenance

Handbrake operating diagram

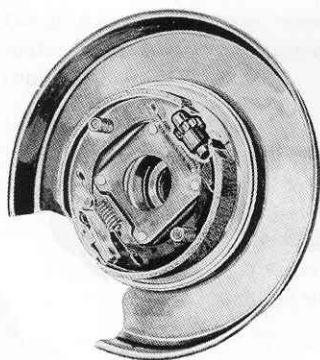

DETAIL VIEW
(drum removed)

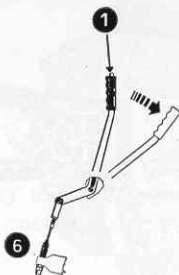

- 1 Control lever
- 2 Operating levers
- 3 Discs
- 4 Shoes
- 5 Running clearance adjuster
- 6 Slack adjuster

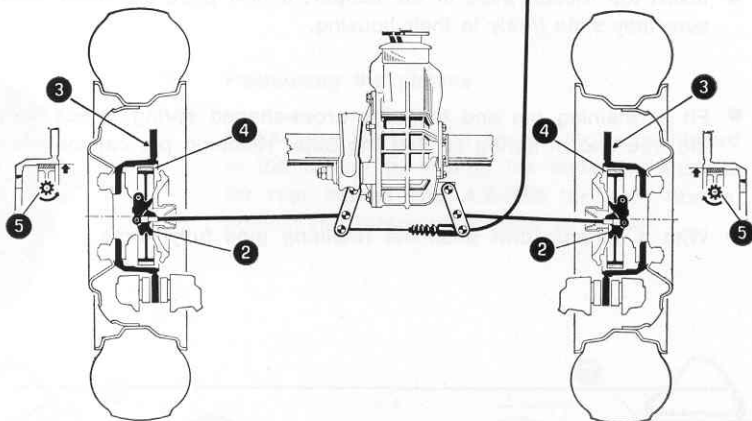

Chassis maintenance

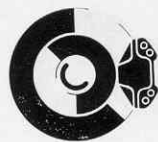

It is mechanically-operated: the rear wheels are locked through shoes 4 acting against a drum machined in the disc casting. Pulling the lever causes the shoes, via the operating levers 2, to expand thus locking the wheels.

Handbrake system

A slack handbrake linkage, due to worn shoe linings, is adjusted as follows, one wheel at a time:

- jack up the car and remove the wheel; fully release the hand brake and make sure the control cables to the calipers are slackened;
- act on the running clearance adjuster 5 one notch at a time in the direction shown in the figure until shoes just contact the drum, then back up the adjuster by two-three notches.

Handbrake linkage adjustment

Gain access to the adjuster 5 with a screwdriver inserted through one of the holes in the disc casting: if hole and adjuster are not aligned rotate the disc.

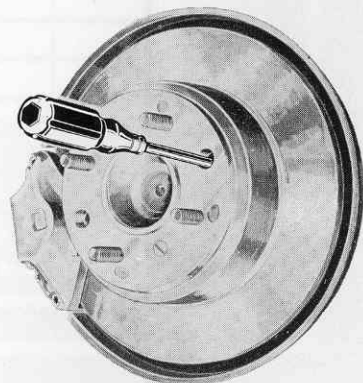

The handbrake is correctly adjusted when the wheels become locked as the lever is drawn through half its total travel. If, after this adjustment, the linkage is yet slackened proceed as follows:

- rotate the adjuster 5 until shoes contact the drum and lock it;
- take up any slackening in the linkage by means of the slack adjuster 6;
- back up the adjuster 5 by two-three notches; in this condition the handbrake linkage will be correctly adjusted.



Chassis maintenance

Cleaning instructions

To clean the outside of brake assemblies use suitable detergents mixed with hot water; then thoroughly dry all components with compressed air.

Never use gasoline, trichloroethylene or similar solvents to clean the outside of brakes as these substances are detrimental to the rubber seals.

While servicing the car, be careful not to let lubricants come in contact with the discs and friction pads.

When cleaning the underside of the car, it is advisable to mask off the brakes to avoid damaging the brake components with jets of water.

Important warning

In case of accident or damage to the chassis check that the brake vacuum servo is undamaged, since even slight superficial body damage may seriously impair the functioning of the brakes.

Do not coast downhill with the engine stopped; there will be no suction in the brake vacuum servo and a greater pressure will be needed with the brake pedal to obtain comparable braking effect.

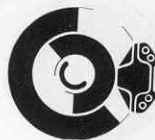

STOPPING DISTANCES!

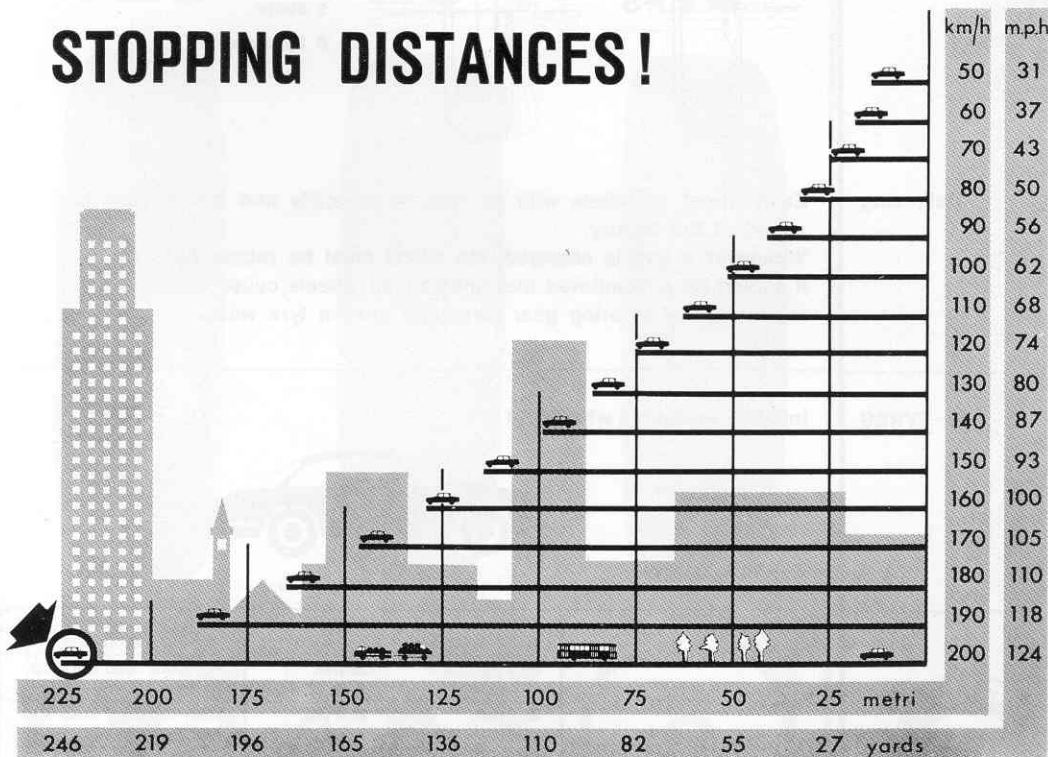

The distance in which the car can be brought to a stop after application of the brakes increases considerably as the speed increases; the distance also varies according to the road surface, and it is much greater when the road is wet or slippery.

The diagram shows stopping distance for various speeds based on ideal conditions, i.e. flat, dry, asphalt roads, good tyres, well adjusted brakes and loads properly distributed over the car.

For safety's sake always bear these stopping distances in mind at all times.



Chassis maintenance

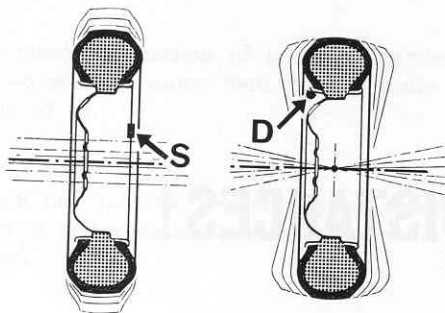

Balance weight location

S Static

D Dynamic

Balancing

Each wheel, complete with its tyre, is statically and dynamically balanced at the factory.

Whenever a tyre is changed, the wheel must be rebalanced.

It should be remembered that unbalanced wheels cause unstable steering, abnormal steering gear wear and uneven tyre wear.

TYRES

Inflation pressures when cold



front

rear



PIRELLI cinturato S

24.2 psi.
(1.7 Kg/cm²)

25.6 psi.
(1.8 Kg/cm²)

With reduced load and touring riding.

KLÉBER Colombes V10GT

25.6 psi.
(1.8 Kg/cm²)

30 psi.
(2.1 Kg/cm²)

With full load and top range of speed.

22.7 psi.
(1.6 Kg/cm²)

24.2 psi.
(1.7 Kg/cm²)

With reduced load and touring riding.

MICHELIN ZX

27 psi.
(1.9 Kg/cm²)

31.3 psi.
(2.2 Kg/cm²)

With full load and top range of speed.

22.7 psi.
(1.6 Kg/cm²)

24.2 psi.
(1.7 Kg/cm²)

With reduced load and touring riding.

24.2 psi.
(1.7 Kg/cm²)

27 psi.
(1.9 Kg/cm²)

With full load and top range of speed.



CEAT | Drive D2

CONTINENTAL

GOOD YEAR - G 800

PIRELLI | cinturato S

MICHELIN | ZX

KLEBER Colombes V 10

24.2 psi.
(1.7 Kg/cm²)

25.6 psi.
(1.8 Kg/cm²)

in all conditions



YES

NO

NO

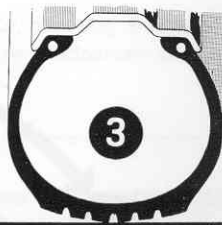
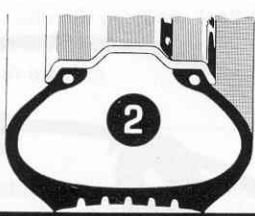
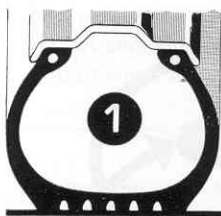
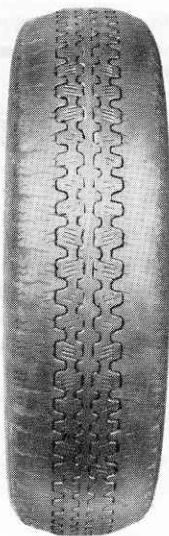
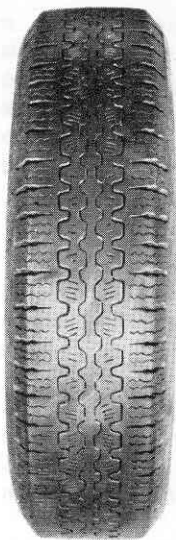

- 1 The tyre gives optimum performance, the tread works over its entire width, thus ensuring **uniform tyre wear and long life.**
- 2 The tyre will overheat: **the sides of the tread will wear quickly** and the tyre plies will tend to separate.
- 3 Riding comfort will be reduced, and the tyre will suffer **from excessive wear in the centre of the tread and vulnerability to knocks.**

Pressure

Correct

Too low

Too high



Chassis maintenance

Changing over

To ensure even and uniform tyre wear and long tyre life, front and rear wheels and the spare should be changed over **at the prescribed intervals.**

MICHELIN diagram

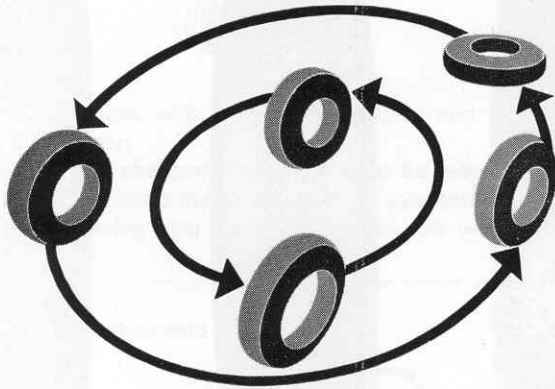

PIRELLI diagram

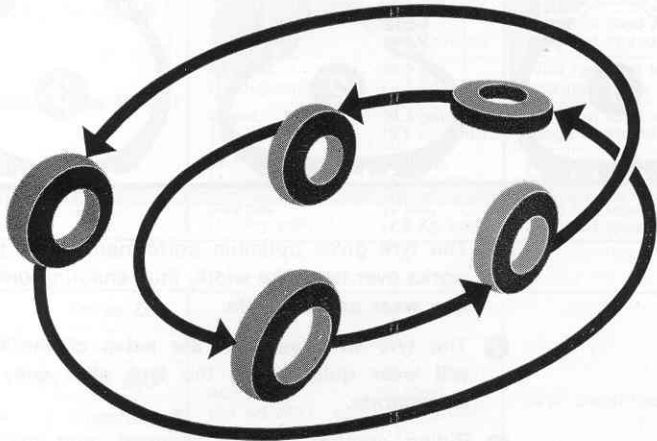

Body maintenance

EXTERNALLY
& INTERNALLY

The body should be washed frequently, depending on the use of the car, the environmental conditions and the state of the roads. Moreover the lighter is the finish paint shade the more frequent the car should be washed.

Avoid washing the car in the sun and proceed as follows:

- first flush the car all over with jets of water to remove the dust;
- prepare a solution of suitable detergent in water (.2% in weight);
- with the solution and a sponge wipe down the whole body;
- rinse thoroughly with plenty of water;
- dry with compressed air, if possible, then with chamois leather.

Note: for cleaning the outside of brakes refer to page 64.

Washing the car

To put fresh gloss on the paintwork, polish once or twice a year with a polish suitable for synthetic or nitrocellulose paint, according to the type of paintwork on the car.

On the chromework use petrol to remove grease and a suitable compound to take out any scratches.

Use only woollen cloth for polishing.

Do not use petrol or solvents on rubber mouldings and weatherstrips. When refuelling or lubricating, be careful not to splash petrol or brake fluid on the paintwork.

Polishing

Use only a very soft cloth or chamois leather for cleaning the windscreen and windows. If the panes are very dirty, use windscreen washer fluid or water mixed with alcohol.

Cleaning the windows

Grease, oil and tar stains may be removed from the paintwork by applying petrol to the stained area, and then rubbing it with a dry cloth. If the tar deposits have hardened, use one of the many preparations available on the market.

Removing stains

Periodically dust the inside upholstery using a vacuum cleaner if possible.

To remove oil and grease stains, use diluted ammonia on the cloth parts and vaseline on the leather.

Use trichloroethylene or neutral soap to remove stains from the carpets. The steering wheel and control knobs may be cleaned with petrol.

Upholstery

If the car will be left unused for any length of time the following protective steps should be taken:

- drain all water from the engine and radiator, preferably while the engine is hot;
- empty the fuel tank, the fuel pump and the carburettor float chamber;
- clean the oil filter and the fuel filter;
- inject a little engine oil into the cylinders through the spark plug holes and rotate the crankshaft by hand several times in order to spread a film of oil over the cylinder walls;
- remove the battery, store it away from frost, and recharge it once a month; never allow it to become fully discharged or plate sulfation will result;
- jack up the car, clean the tyres and slightly deflate them; if tyres are removed, dust them internally (and their tubes) with talcum powder; store them in a dark and airy but dry place;
- dust the seats and upholstery with moth preventive;
- cover the car with a dust sheet. To avoid serious damage to the paintwork, do not use polyvinyl-type tarpaulins.

The 12-volt electrical system is wired with protected and insulated cable in order to reduce to a minimum the risk of short circuiting. The negative battery terminal is grounded.

If any instrument fails to operate or any lamp fails to light up, first check the corresponding fuses; if the fuse is sound check to ensure that the cable terminals are tight and that the bulbs are not loose or burned out. If the trouble persists, the electrical system should be checked by a competent auto-electrician.

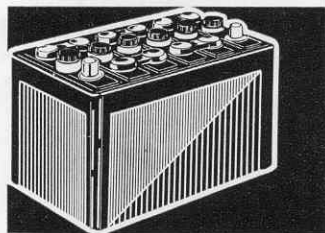

Water level

The battery water level should never be more than 3/16" (4-5 mm) above the plates and must never leave them uncovered.

When filling up the battery, use only distilled water; never add acid.

Terminals

Make sure that terminals are tight and are sufficiently coated with pure vaseline.

State of charge

The state of charge can be checked by measuring the specific gravity of the electrolyte with a suitable hydrometer.

The specific gravity/charge ratio is as follows:

specific gravity	{	1.28 (32° Bé) = charged
		1.23 (27° Bé) = half charged
		1.11 - 1.14 (15° - 18° Bé) = discharged

If distilled water has been added to a battery, the specific gravity should not be measured until mixing is complete; to facilitate mixing, charge the battery for 30 minutes.

In tropical climates where the temperature is nearly always above 30°C (85°F), the specific gravity of the electrolyte, when the battery is fully charged, must be lower than the normal figure, viz 1.21 (25°Bé).

BATTERY

Starting motor and generator

Regularly:

Inspect commutator and brushes of generator and starting motor. The brushes must be clean and must slide freely in their holders; brush working face must be cleaned with a cloth soaked with gasoline; the brush spring must apply effective pressure.

When one brush has to be replaced, it is a good rule to replace the other at the same time. Always fit new original brushes of the prescribed type.

After replacing the brushes, run the generator (or starting motor) with no load and for such time as is necessary to bed the brush working face to the commutator.

If the commutator is burned or elongated, it must be reworked on a lathe taking care to decrease the diameter of the minimum required only; after machining, undercut the mica between the segments.



The headlamp beam setting should be checked against the figures indicated in the diagram, with the car unladen on a level surface, and an absolutely vertical screen. To correct any discrepancy in the setting, remove the outer rim and rubber seal and turn the adjusting screws as required.

V = screw for vertical adjustment

O = screw for horizontal adjustment

The outer rim is fixed by a screw through a locating tab.

When replacing, be careful to put on the rubber seal the right way, one side is marked «RE-TRO» (rear), with the cutaway edge positioned to correspond with the screw fixing the rim.

The pattern shown refers to cars for export to R.H. rule or road countries; for L.H. rule of road, the pattern is exactly opposite, i.e. upper area slanting from left to right.

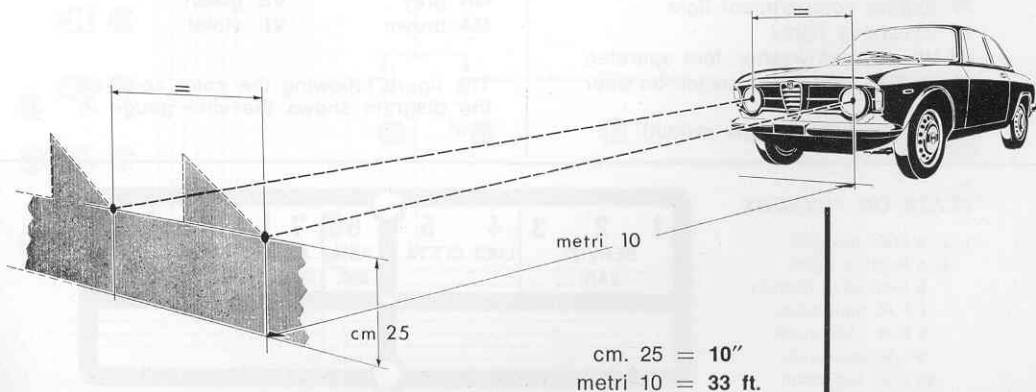
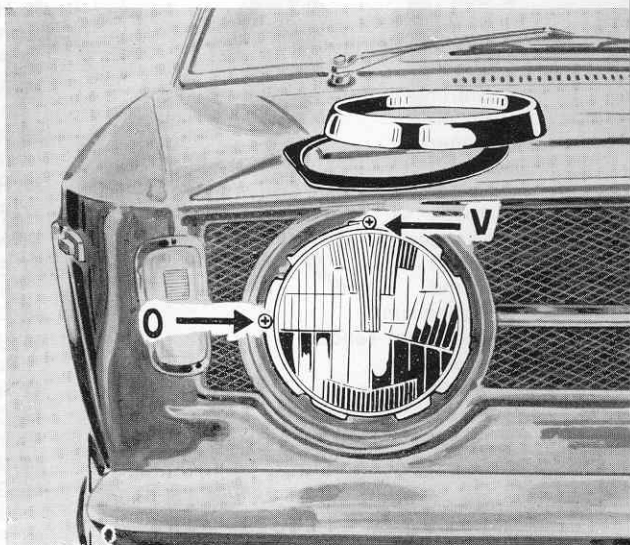

WIRING DIAGRAM

- 1 Battery 12 V-60 Ah
- 2 Coil
Bosch K 12 V
- 3 Ignition distributor
Bosch JF 4
- 4 Starting motor
Bosch EF(R) 12 V 0,7 PS
- 5 Generator
Bosch EG(R) 14V 25A 29
- 6 Voltage regulator
Bosch VA 14 V 25 A
- 7 Windscreen wiper
Bosch WS 4903 AR2A (0)
- 8 Horns
- 9 Flasher unit
- 10 Fuel level sender
- 11 Fusebox
- 12 Junction box
- 13 Relay
- 14 Coolant temperature gauge bulb
- 15 Pressure switch for oil warning light
- 16 Oil pressure gauge sender
- 17 Pressure switch for stop lights
- 18 Blower motor
- 19 Cigar lighter

SWITCHES

- 20 Parking lights, headlamps and flashing
- 21 Direction indicator
- 22 Horn control
- 23 Stop lights
- 24 Blower motor
- 25 Dashboard lights
- 26 Windscreen wiper motor
- 27 Engine compartment light
- 28 Reversing lights
- 29 Windscreen washer, foot operated
- 30 Ceiling light (microswitch on door jams)
- 31 Ceiling light (toggle switch)

BULBS

- 32 High/low beam (headlamps) 40/45 watts asymmetric
- 33 Parking & Stop lights 5/21 watts
- 34 Front direction indicators)
- 35 Rear direction indicators) 21 watts
- 36 Reversing lights)
- 37 Front parking lights 5 watts
- 38 Number plate light globular
- 39 Engine compartment light 5 watts
- 40 Ceiling light cylindrical
- 41 Side direction indicators)
- 42 Instrument light)
- 43 Oil pressure warning light 3 watts tubular
- 44 Blower warning light)
- 45 Generator warning light)
- 46 Fuel reserve warning light)
- 47 Direction indicator warning lights) 1.2 watt tubular
- 48 Parking light warning)
- 49 High beam warning light)

CABLE COLOR CODE

- | | |
|------------------|------------------|
| AZ blue | NE black |
| BI white | RO pink |
| GI yellow | RS red |
| GR grey | VE green |
| MA brown | VI violet |

The figure following the color code on the diagram shows the wire gauge in mm².

PLATE ON FUSEBOX

- 1, 2, 3 Main devices
- 4, 5 Parking lights
- 6 Indicating devices
- 7 L.H. high beam
- 8 R.H. high beam
- 9 L.H. low beam
- 10 R.H. low beam



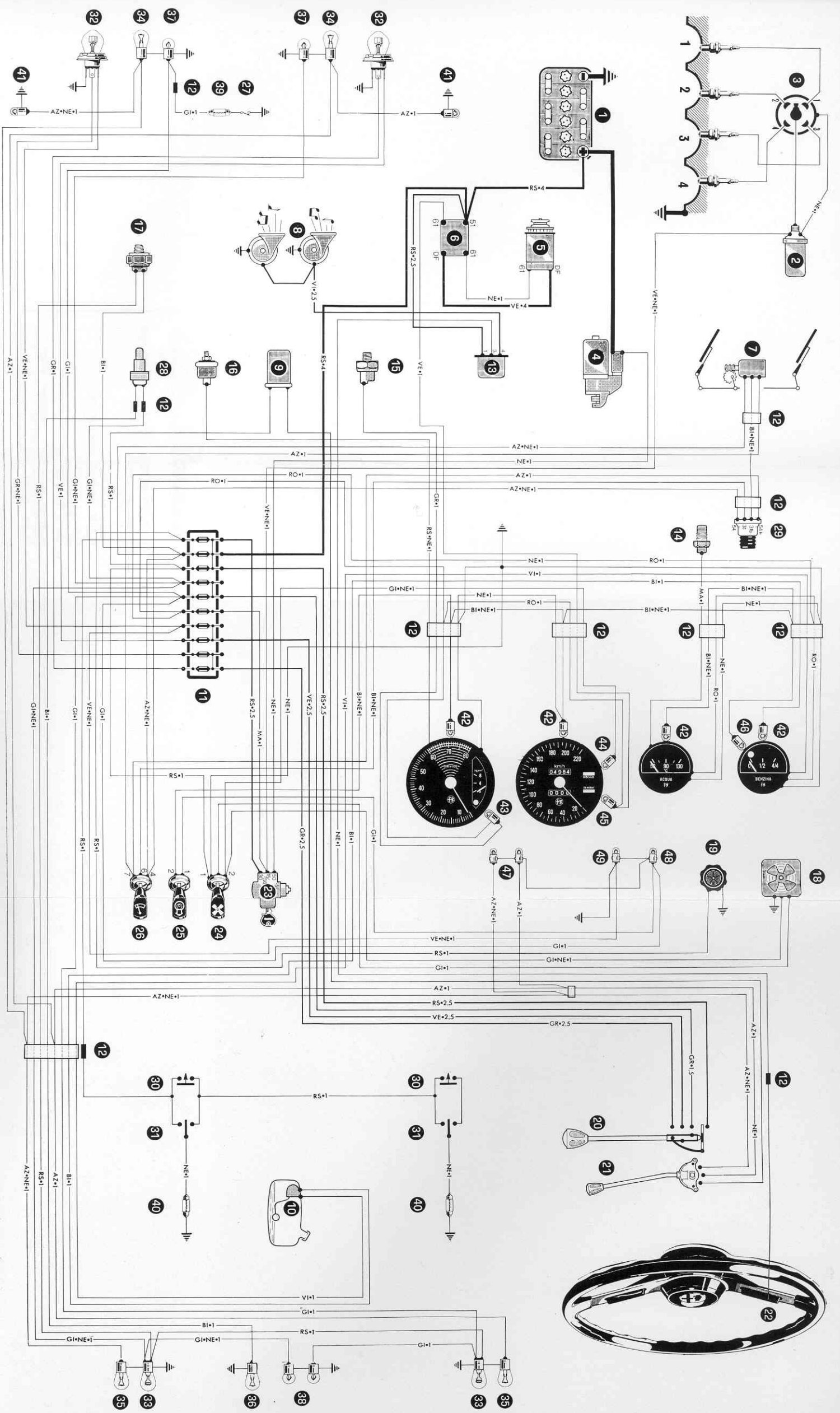

Alfa Romeo

Via Gattamelata, 45 - 20149 MILANO

DIASS - Pubblic. N. 1490-R1
5/71 - 1.500

Printed in Italy
Arti Grafiche Milanesi - Milano

Stampato su carta
patinata Sterzi da
gr. 200 e 100 al mq.

All rights reserved. This book, or parts thereof, may not be reproduced in any form without permission of Alfa Romeo S.p.A.