

■ GIULIA AND 1750 MODELS ■

■ BODY ■

Alfa Romeo

SHOP MANUAL



THIS PUBLICATION IS DESIGNED TO GIVE THE ALFA ROMEO SERVICE NETWORK A COMPLETE BACKGROUND OF INFORMATION ABOUT CHECKING, REPAIRING AND REFINISHING THE BODY; FURTHER, THE REPAIR, REMOVAL AND INSTALLATION, INSPECTION AND ADJUSTMENT OF MAJOR ITEMS, ESPECIALLY THOSE OF THE 1750 SALOON, ARE COVERED IN DETAILS.

BEST RESULTS CAN BE OBTAINED ONLY WHEN CHECKING AND RECONDITIONING WORK IS PERFORMED WITH THE AID OF THE SUITABLY PROVIDED SPECIAL TOOLS AND WHEN ONLY GENUINE ALFA ROMEO REPLACEMENT PARTS ARE USED.

THIS MANUAL SHOULD BE KEPT CONTINUOUSLY UP-TO-DATE BY THE ADDITION OF NEW SPECIFICATIONS AND INSTRUCTIONS ISSUED AT INTERVALS BY THE TECHNICAL SERVICE DIVISION IN THE REGULAR "INFORMATION SHEETS" AND "MODIFICATION INSTRUCTIONS"

Direzione Assistenza *Alfa Romeo*

CONTENTS

- 3 General notes on body repairing

BODY ALIGNMENT CHECKING BENCH

- 5 General
- 6 Positioning the jigs
- 7 Component parts
- 8 Preparing the bench and the body
- 12 Alignment checking
- 14 Diagram of dimensions of main unit attachments

BODY REPAIR

- 15 Front cross member replacement
- 22 Replacing the fender and front panels
- 28 Replacing the tail panel
- 29 Replacing the rear wing assembly
- 30 Bringing windscreen frame back into shape

REMOVAL AND INSTALLATION

- 31 Windscreen and rear window glass
- 36 Doors
- 37 Door trim panels
- 38 Door glass frames
- 39 Door locks
- 43 Window regulators
- 44 Door glasses
- 45 Front vent windows
- 47 Door weatherstrips
- 49 Front seats
- 50 Facia board
- 54 Console
- 57 Roof trimming
- 65 Insulation padding

CHECKING AND ADJUSTING

- 66 Door locks
- 69 Engine hood
- 72 Luggage compartment lid
- 73 Door weatherstrip leakage
- 74 Luggage compartment sealing
- 75 Water test
- 76 Sealing
- 84 Sound deadener

REFINISHING

- 85 General
- 86 Finish identification
- 87 How to order finish material
- 87 Colour matching
- 88 Painting process
- 95 Painting troubles
- 96 Painting trouble shooting

SPECIAL TOOLS

- 103 List of special tools

GENERAL NOTES ON BODY REPAIRING

When undertaking any body repair operation, it is advisable to follow a standard technique as detailed in the following notes. If the body shows deep distortions resulting from a collision or an accident, the damaged parts must be replaced with new ones; this will ultimately save money and will ensure that both car's styling and structure are restored.

All body component parts are available as spares and are also entered in the spare parts catalogue of the model concerned.

- For replacing, the damaged parts must be cut off along the joining lines, suitably designed for this purpose, with the aid of tin snips, trimming shears, hack saws or similar means suitable for straight cutting the sheet metal without warping it. To drill through the spot welds, use drills slightly larger in diameter than spots (drill O.D. from 3 to 4 mm) so as to avoid stressing the parts to be left in while attempting to tear off spot welds. To separate arc welded parts, use chisel to chip off the beads or grind the beads down in order to prevent putting structural components under undue strains; with the chisel, part then sheet metal panels from each other.
- Trim and smooth out the edges of cut off panels. Properly fill all holes, left after drilling the spot welds, by welding with a filler rod. Carefully trim with a file the edges to be joined together both of body sheet metal and replacement panel and get rid of any sign of finish material from areas to be welded.
- To prevent the spot welds from oxidizing, especially those particularly exposed to atmospheric agents, coat the affected parts with a suitable rust inhibiting compound before welding.

WARNING – On models featuring A.C. generators, disconnect terminals before welding to prevent damaging the diodes.

- Keep parts properly positioned by clamping them in place; where this is not practicable, make some spot welds to hold the parts together.

GENERAL NOTES ON BODY REPAIRING

- After ensuring that all parts are in proper alignment, weld the components together following, as to spot weld diameter and spacing or arc welding beads, the factory's technique. Remove welding scales by peening and smooth out any roughness. Slight dents or bulges in body panels can be corrected by hammering.

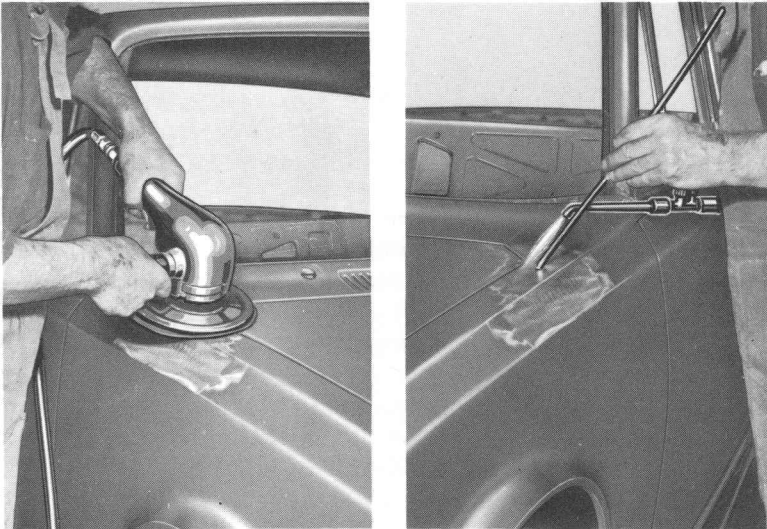

- If imperfections persist, smooth out the affected areas with a body grinder, taking care not to reduce excessively the thickness of sheet metal, especially along the edges or the stiffening ribs. If the surfaces are not perfectly flush, fill low spots with body solder.

- If suitable templates are not available, doors and lids can be checked for proper fit with their openings by means either of new replacement parts or doors and lids themselves of the car being repaired provided that not warped out of shape.

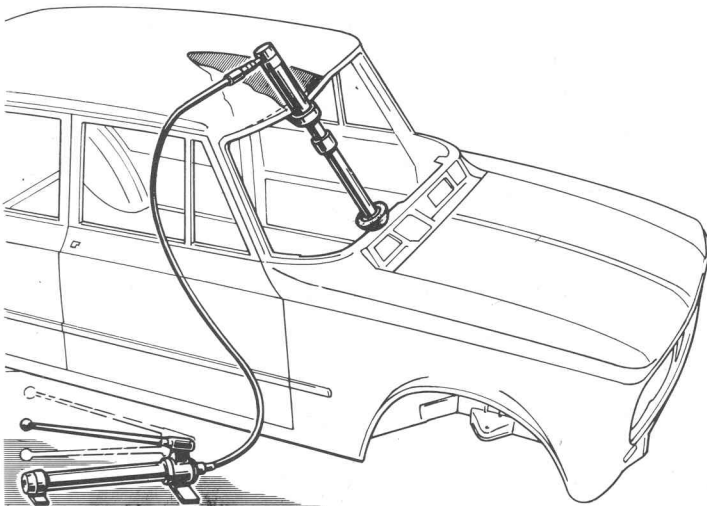

- Should an opening require to be brought back into alignment with the use of hydraulically-controlled straightening jacks, special care must be taken to avoid stressing out of line other parts of body that previously checked within alignment limits.

Performing the repair operations in workmanlike manner, as a guarantee that the structural strength has not been impaired, rests on the operator's skill and responsibility.

CAUTION – When accomplishing repair works, always use suitable clothing and observe all safety precautions as prescribed by safety regulations.

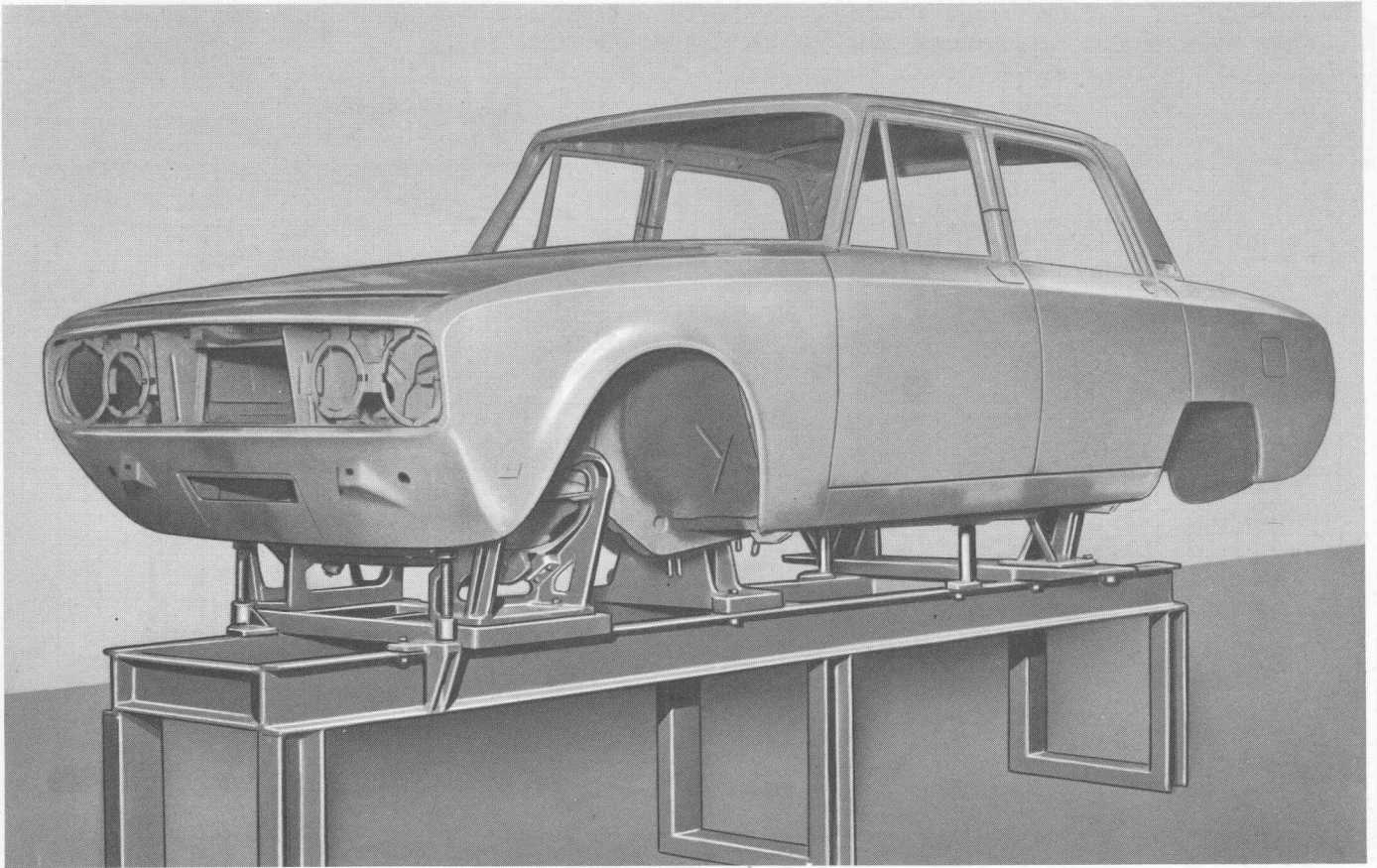

If the body shows sign of warping it must undergo a bench check.

To this purpose, remove the engine compartment lid and all mechanical units: engine, clutch, gearbox, rear axle, front and rear suspension, steering gear, radiator, exhaust pipe.

An overhead crane is the most convenient means for hoisting the body and placing it over the bench.

If the body does not fit or fits improperly to the alignment checking jigs, it must be brought back into line or the distorted components replaced with new ones.

As an aid for the bodyman, further details on this matter are given in the following pages together with the procedures for carrying out the checks and some repairs.

BODY ALIGNMENT CHECKING BENCH

POSITIONING THE JIGS

The position of the jigs varies according to the car model. The dimensions specified below should therefore be adhered to as applicable.

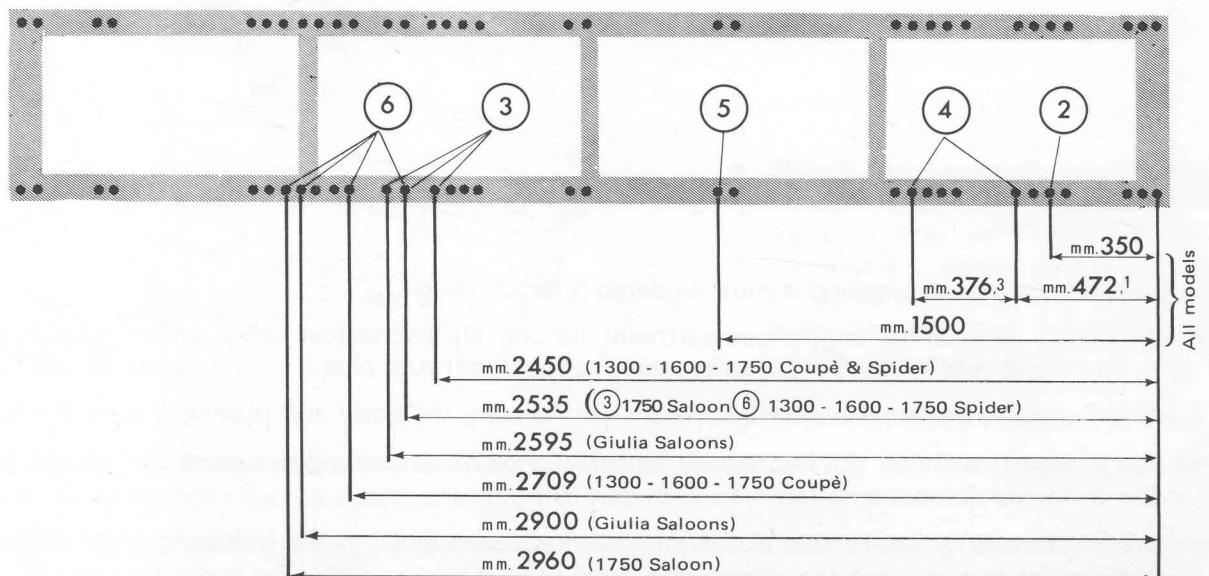
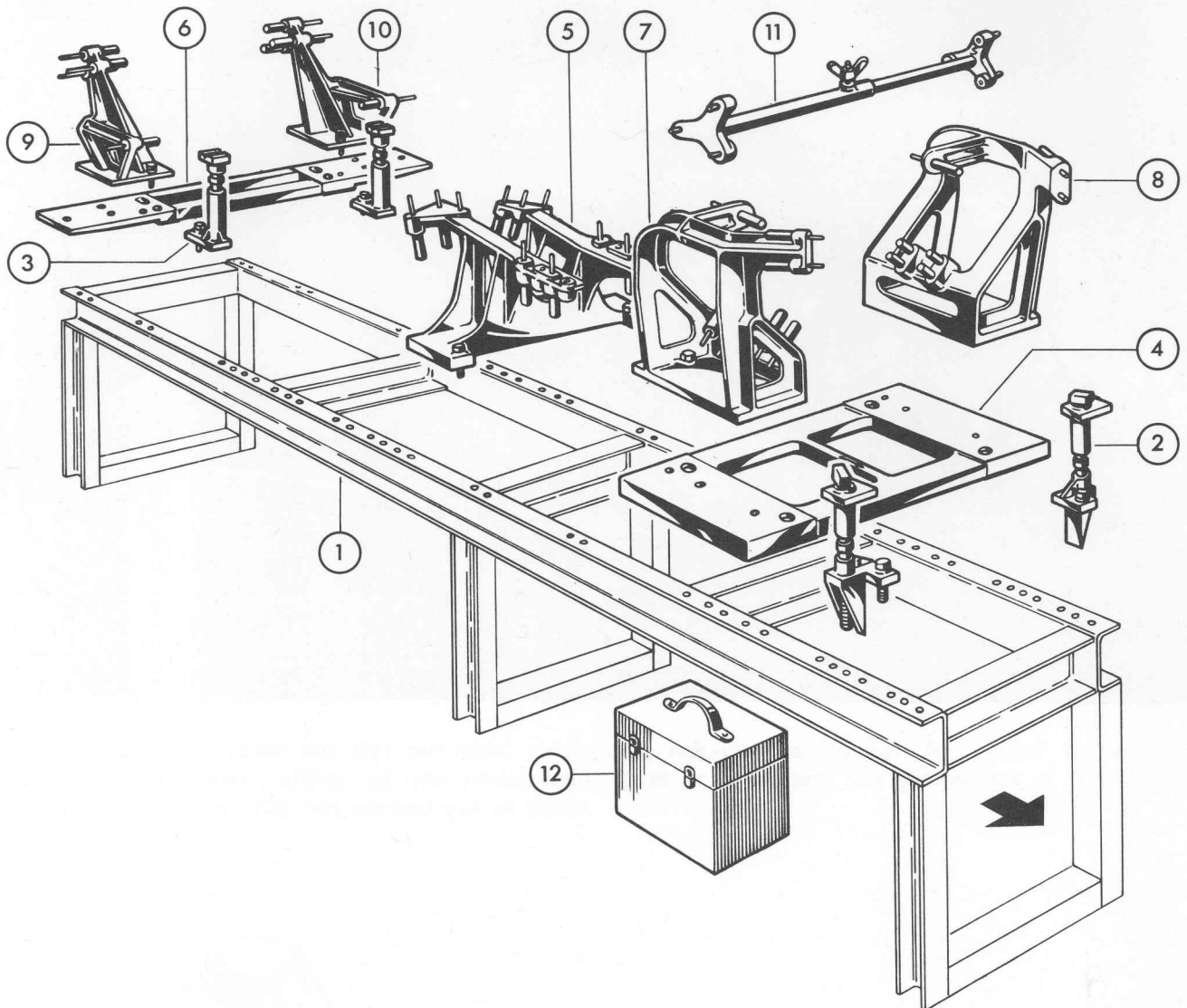

COMPONENT PARTS

LIST OF COMPONENTS OF BENCH A.8.0901				
Item no.	Part no.	Quantity	Nomenclature	Car model
1	A.8.0007	1	Bench with jig positioning holes	All models
2	A.8.0016	2	Screw jack for front support of frame	
3	A.8.0017	2	Screw jack for rear support of frame	
4	A.8.0068	1	Front plate for resting of front suspension jig	
5	A.8.0083	1	Jig for checking gearbox support cross-member and center cross-member attachments	All models less 1750 Saloon
	A.8.0073	1	Jig for checking gearbox support cross-member and center cross-member attachments	Only 1750 Saloon
6	A.8.0013	1	Cross member for resting of rear suspension jigs	All models
7	A.8.0072	1	Jig for checking R.H. front suspension attachments	
8	A.8.0071	1	Jig for checking L.H. front suspension attachments	
9	A.8.0054	1	Jig for checking R.H. rear suspension attachments	
10	A.8.0055	1	Jig for checking L.H. rear suspension attachments	
11	A.8.0056	1	Extension gauge for checking steering box & relay crank attachments	
12	A.8.0801	1	Box containing 36 steel dowels as detailed below	

DOWEL SET				
Item no.	Part no.	Quantity	Nomenclature	Car model
12	A.8.0057	4	Parallel dowels for holes of lower arm of front suspension	All models up to model year 68
	A.8.0064	8	Parallel dowels for holes of lower arm of front suspension	All models from model year 68
	A.8.0060	8	Threaded dowels – 4 of which for gearbox attachment holes – 4 of which for the holes in slanting rods of front suspension upper arms	All models
	A.8.0061	6	Threaded dowels for center cross-member attachment holes	
	A.8.0062	2	Parallel dowels for radius rod attachment holes	
	A.8.0063	6	Parallel dowels for T-arm attachment holes	
	A.8.0059	2	Parallel dowels for hole of transverse rod of front suspension upper arm	
NOTE – Dowels are not supplied separately, but as a set.				

BODY ALIGNMENT CHECKING BENCH

PREPARING THE BENCH AND THE BODY

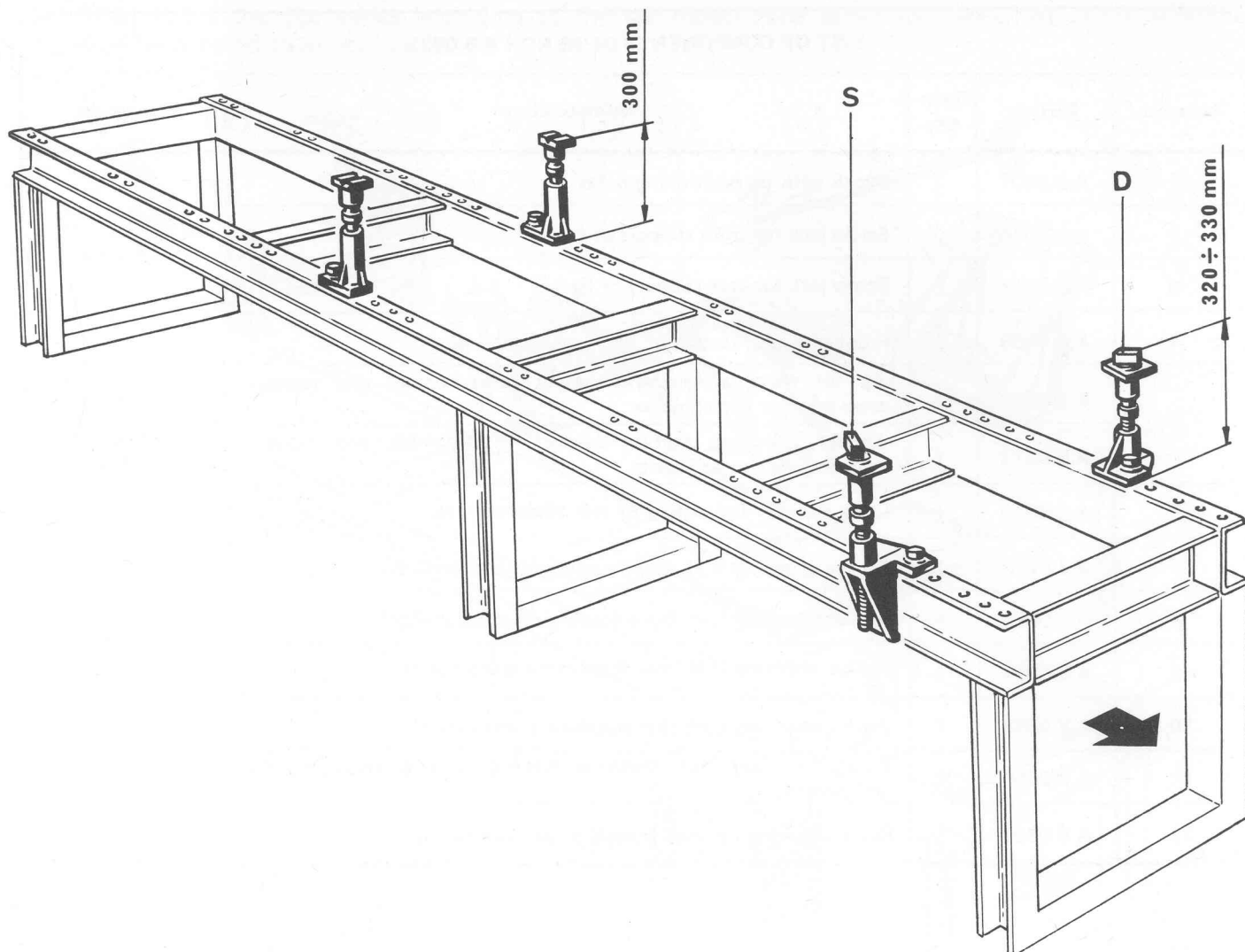

- Place the bench on a level floor.
- Fit the front and rear screw jacks (do not lock in place those at the rear) and adjust them to the following height from the bench top:
 - Front: 320 to 330 mm
 - Rear: 300 mmIt is essential that each pair of jacks is set to the same height.

CAUTION – Make sure the front jack with the S marking is placed at the right side while that with the D marking is at the left side.

PREPARING THE BENCH AND THE BODY

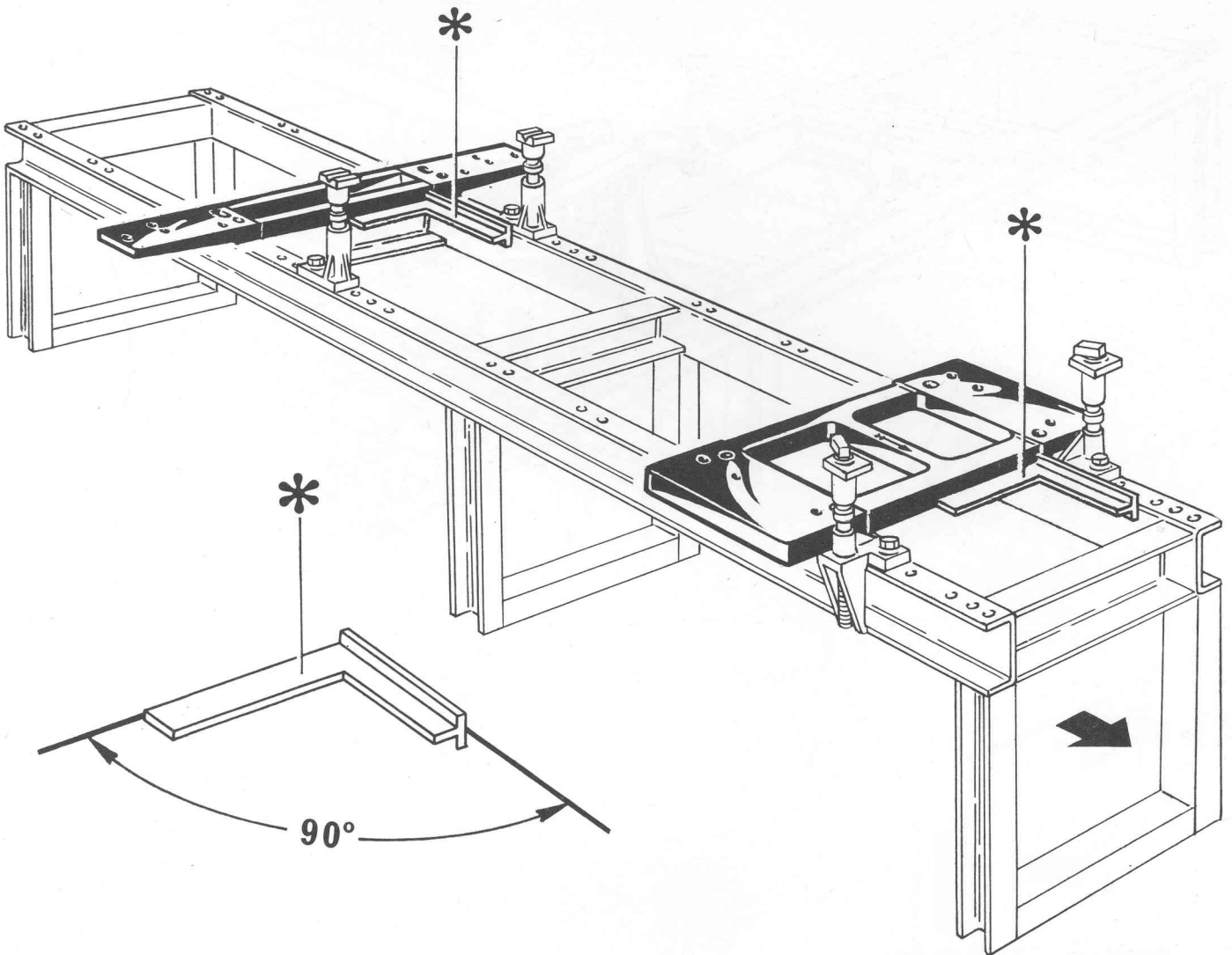

- Secure in place the front plate and the rear cross-member making certain they are exactly at right angle with the rails.

WARNING – The accuracy of results depends closely upon the correct setting of plate and cross-member.

BODY ALIGNMENT CHECKING BENCH

PREPARING THE BENCH AND THE BODY

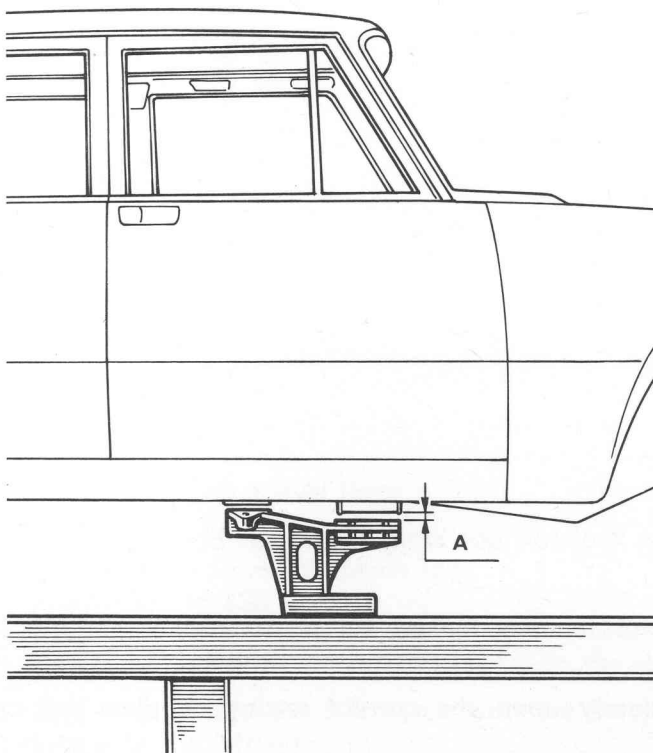
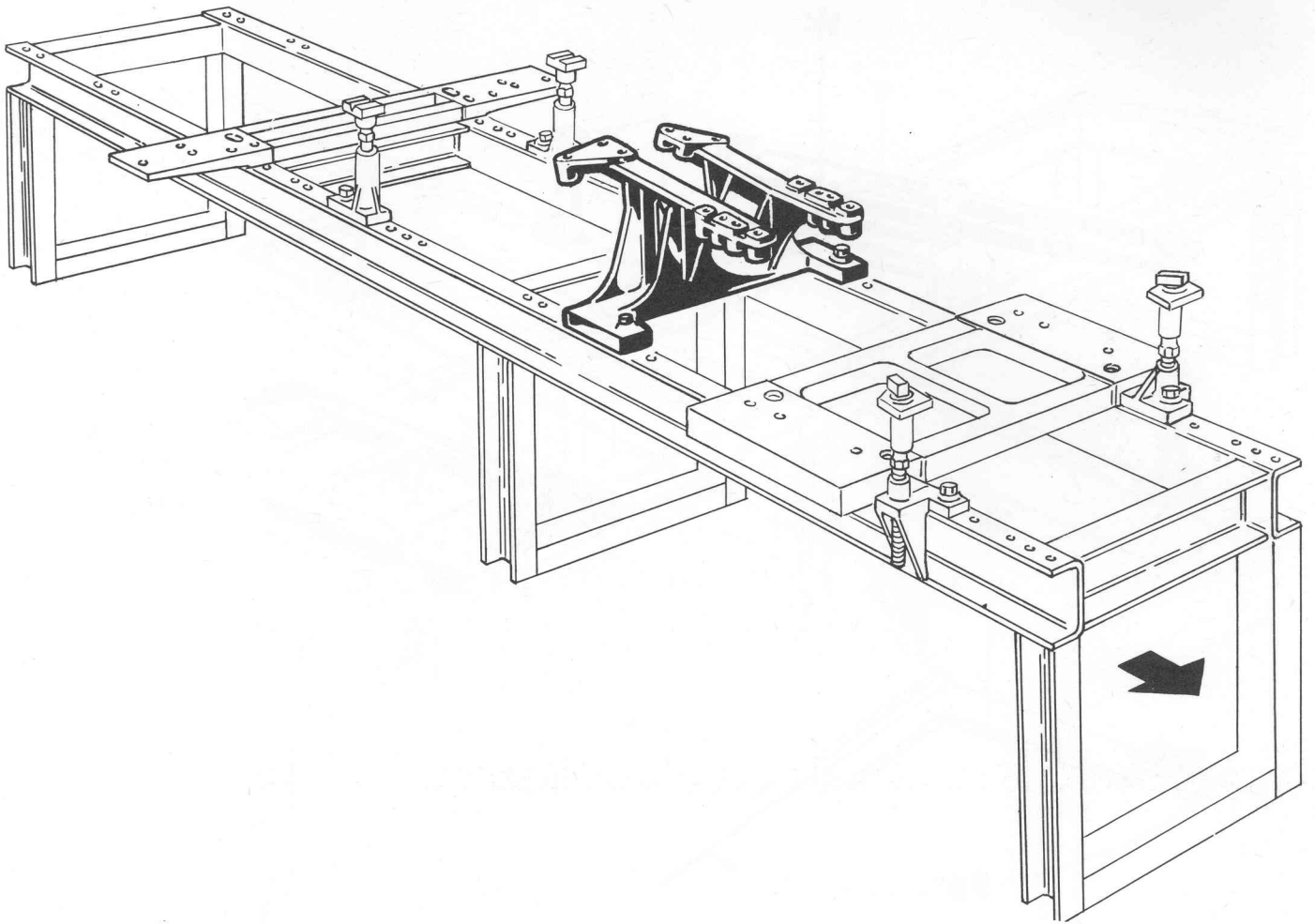

- Secure in place the centre jig for checking the gearbox support cross member and centre cross member attachments.
- Hang the body over the bench then lower it slowly on the rear jacks. Adjust the position of the rear jacks lengthwise and secure them in place. Lower the body further so that it rests on the four jacks.
- Act on the adjusting screws of jacks until there is a clearance A of 4 to 5 mm between the body and the centre jig.

PREPARING THE BENCH AND THE BODY

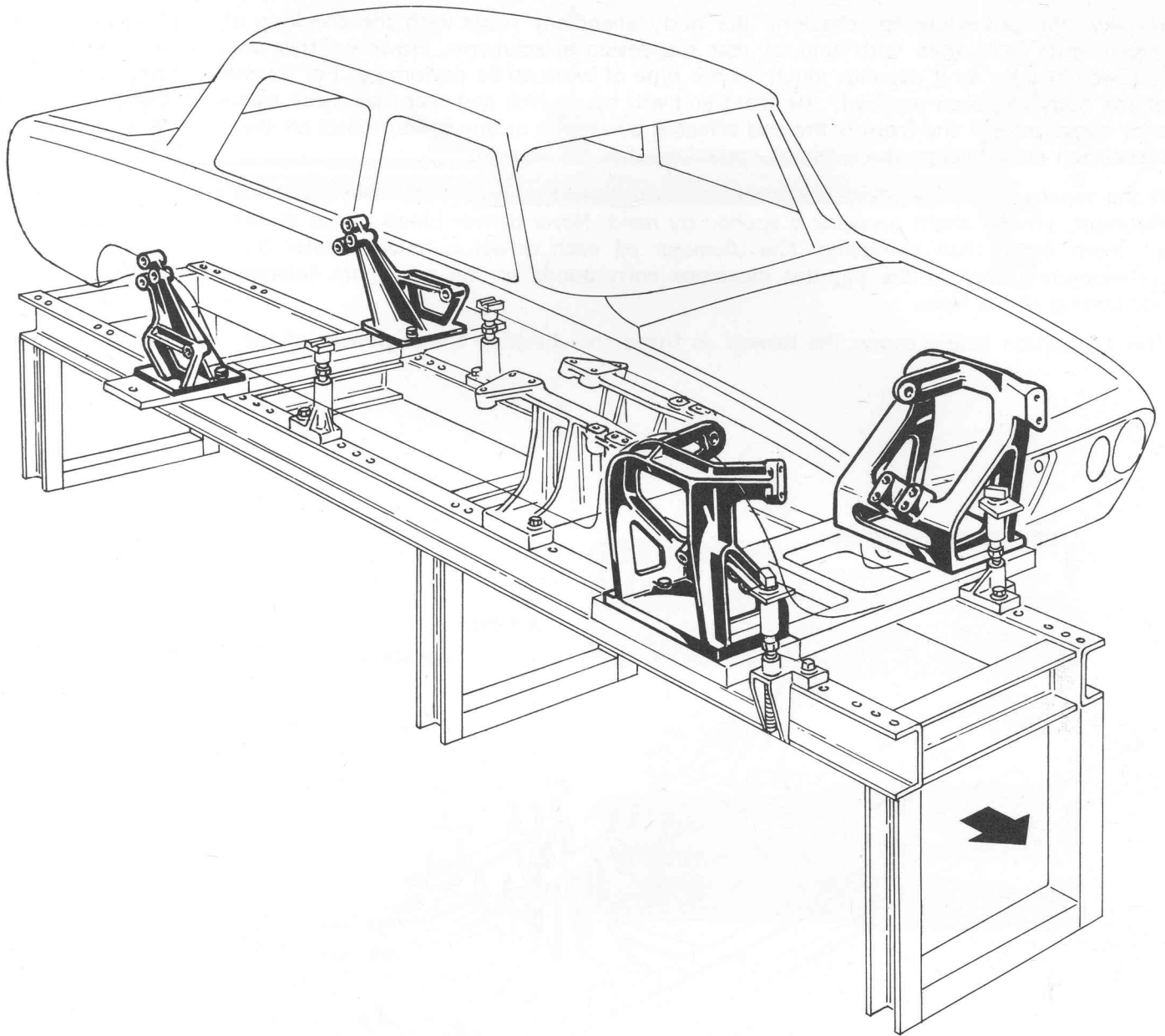

- Bring the suspension attachment checking jigs close to the body after having placed them on the suitable surfaces of the bench cross members. Secure in place only after the body has been definitively positioned.

CAUTION – Should any difficulty arise in mounting the rear jigs, slightly raise the body.

- Lower the four jigs until there is a clearance A of 1 to 2 mm between the body and the centre jig. The body is definitively positioned when the attaching holes are in line with those in the jigs.
- Firmly secure the jigs to the supporting cross members.

BODY ALIGNMENT CHECKING BENCH

ALIGNMENT CHECKING

Usually, the procedure for checking the body alignment starts with the checking of front suspension attachments first, then with that of rear suspension attachments. However, this sequence may not be followed strictly as it depends much on the type of work to be performed. For example, if the rear end of the body has been repaired, the front end will be set first and then the check carried out on the rear end; conversely, if the front is the end affected by repairs or any doubt exists on the alignment of front suspension attachments, the order of operations shall be reversed.

If the repairs have been skillfully carried out, all dowels should match freely the respective holes or, at the most, after a slight pressure is applied by hand. Never deliver blows to the dowels or apply pressure on them other than manually. The diameter of each dowel is much smaller than the bore of the corresponding hole in the jig; this clearance corresponds to the maximum tolerance allowed for the positioning of the hole.

The illustration below shows the dowels as fitted for checking the alignment of the 1750 Saloon body.

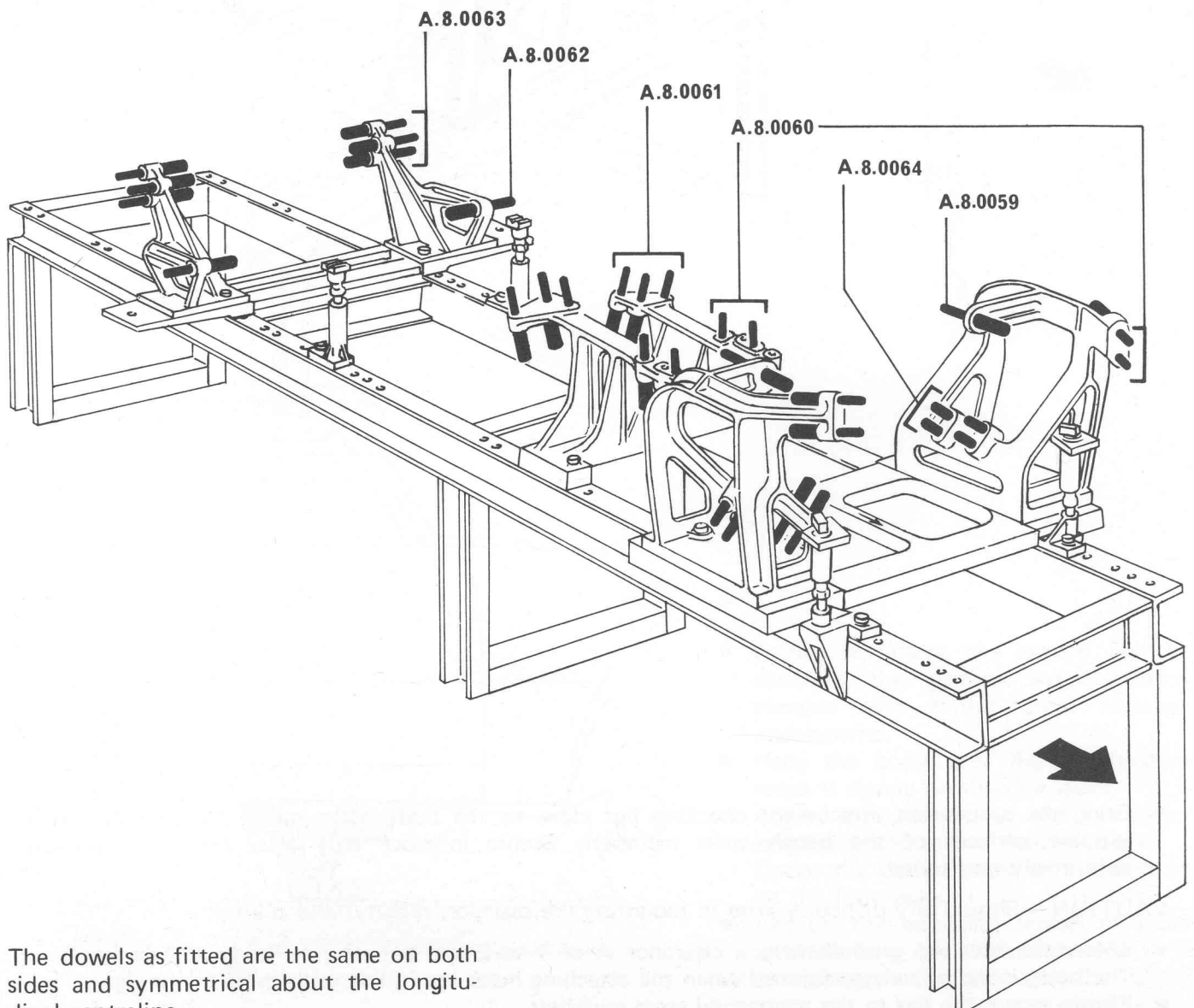

The dowels as fitted are the same on both sides and symmetrical about the longitudinal centreline.

ALIGNMENT CHECKING

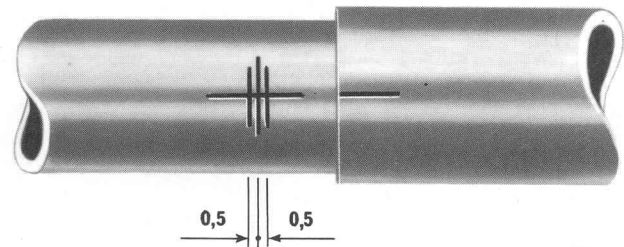
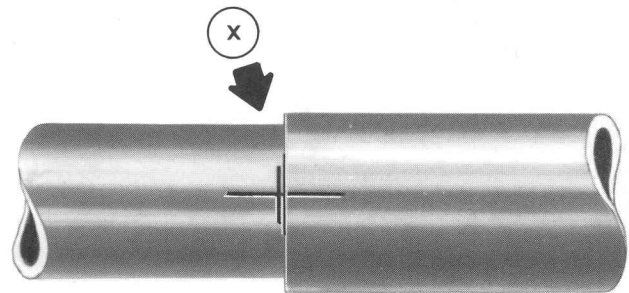
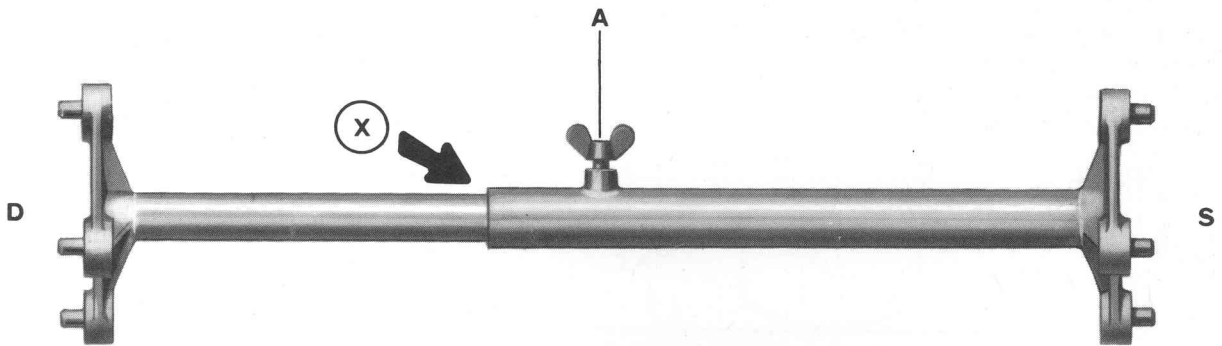

For checking the steering box and the relay crank attachments, use the extension gauge, special tool P.N. A.8.0056, and, acting from inside the engine compartment, proceed as follows:

- Hold the extension gauge in such a way that the wing nut A is pointing upward and make sure that the end flanges bearing the markings S and D are positioned respectively at the left and at the right skirt.
- Slacken the wingnut A and extend the gauge so that the dowels on the end flanges can be inserted in the holes in the skirts.
- Check that the reference marks on the two gauge tubes are aligned perfectly or within a maximum tolerance of ± 0.5 mm.

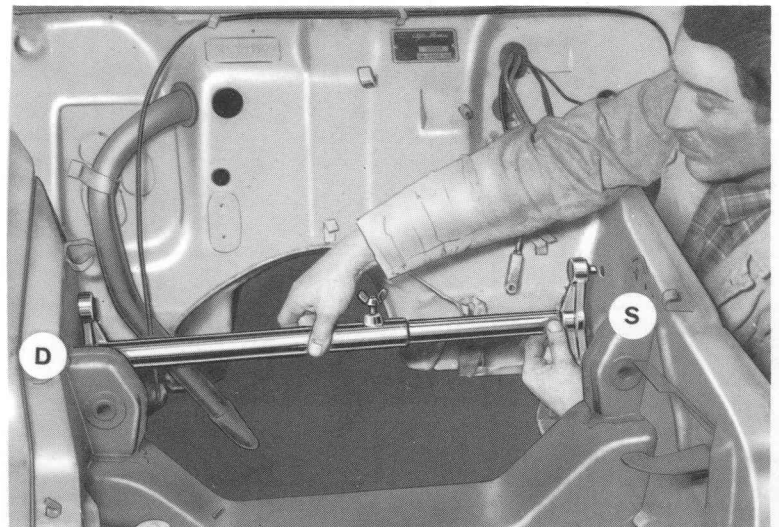

DIAGRAM OF DIMENSIONS OF MAIN UNIT ATTACHMENTS

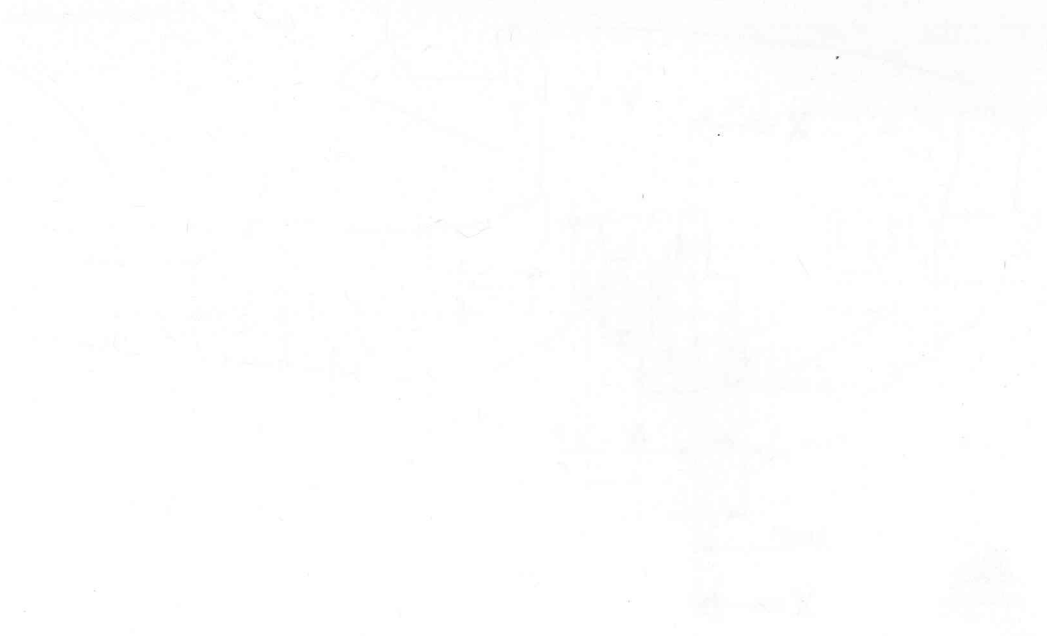
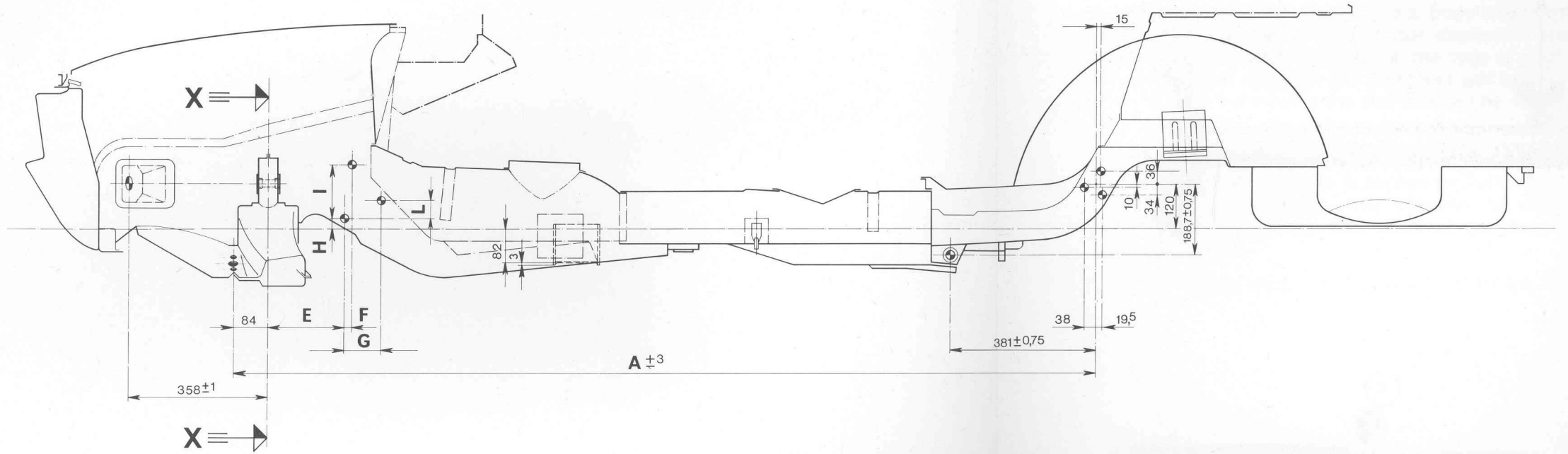
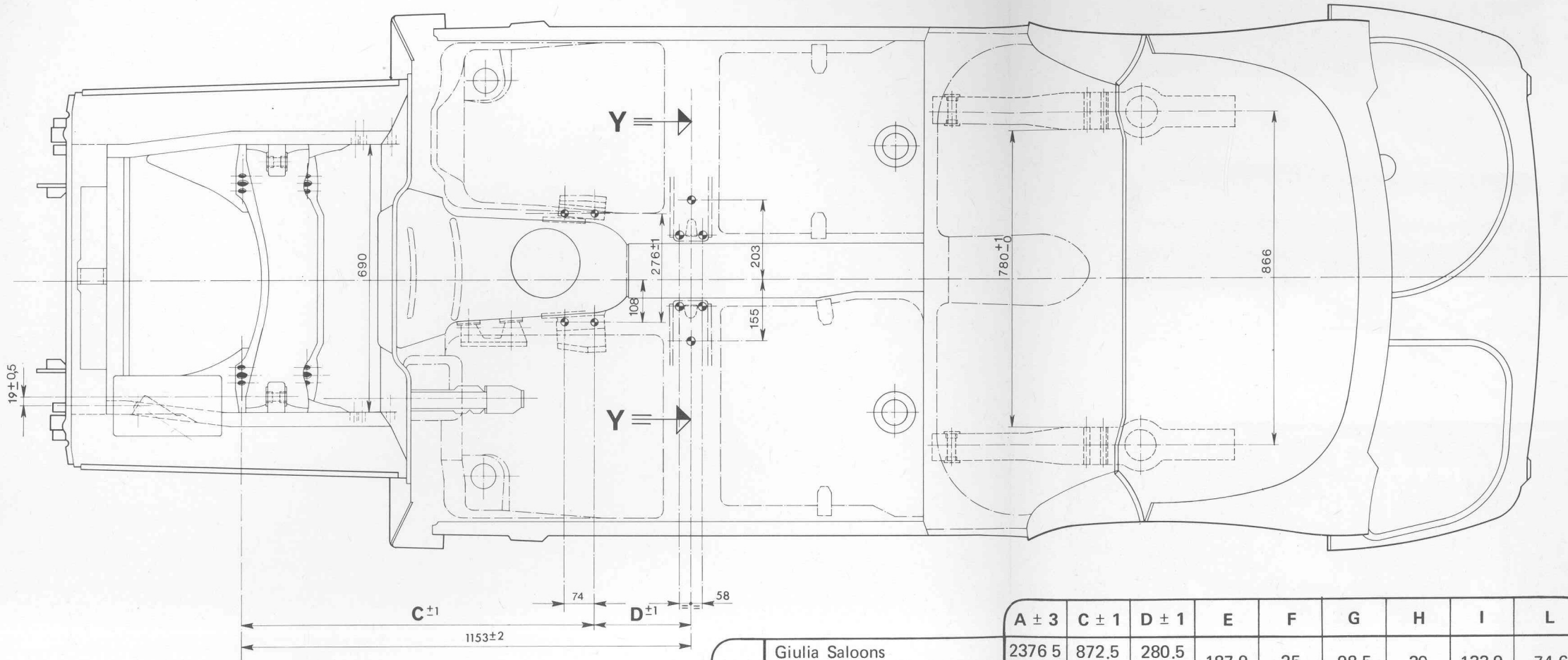

DIAGRAM OF DIMENSIONS OF MAIN UNIT ATTACHMENTS



DIAGRAM OF DIMENSIONS OF MAIN UNIT ATTACHMENTS





	A ± 3	C ± 1	D ± 1	E	F	G	H	I	L	
MODEL	Giulia Saloons	2376.5	872.5	280.5	187.9	25	98.5	30	133.9	74.6
	1750 Saloon	2436.5	870	283						
	Coupé 1300-1600	2216.5	872.5	280.5	190.5	34.2	101.25	33.25	131.75	70.5
	Coupé 1750		909	244						
	Spider 1300-1600	2116.5	872.5	280.5						
	Spider 1750		909	244						

Dimensions in millimetres

Y-Y

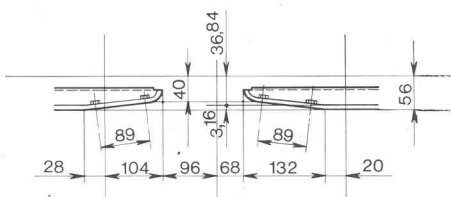

X-X

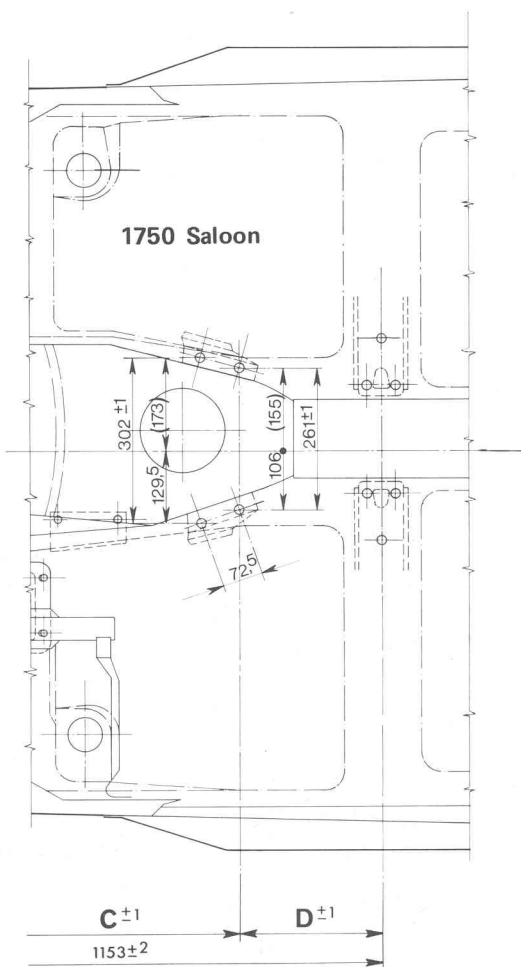
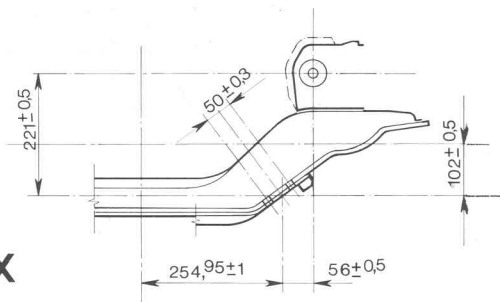
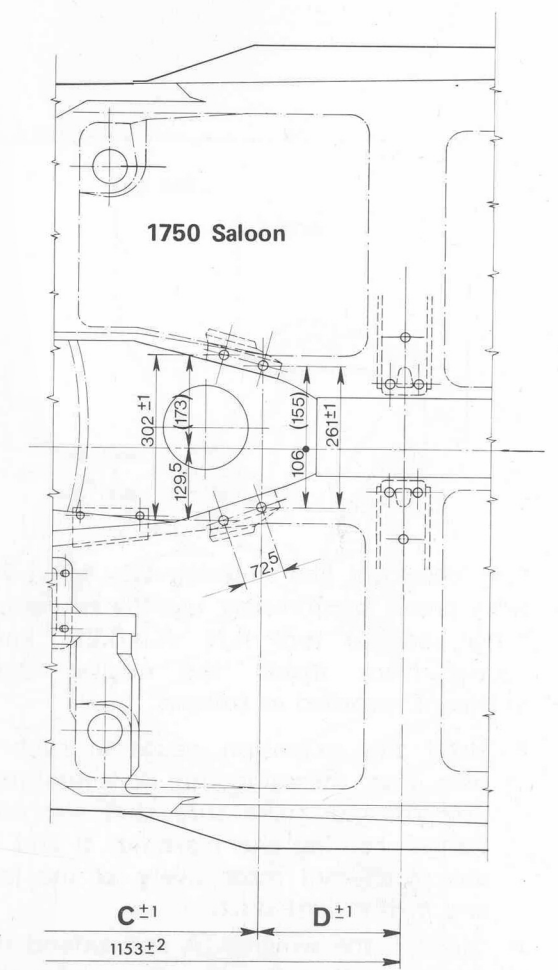
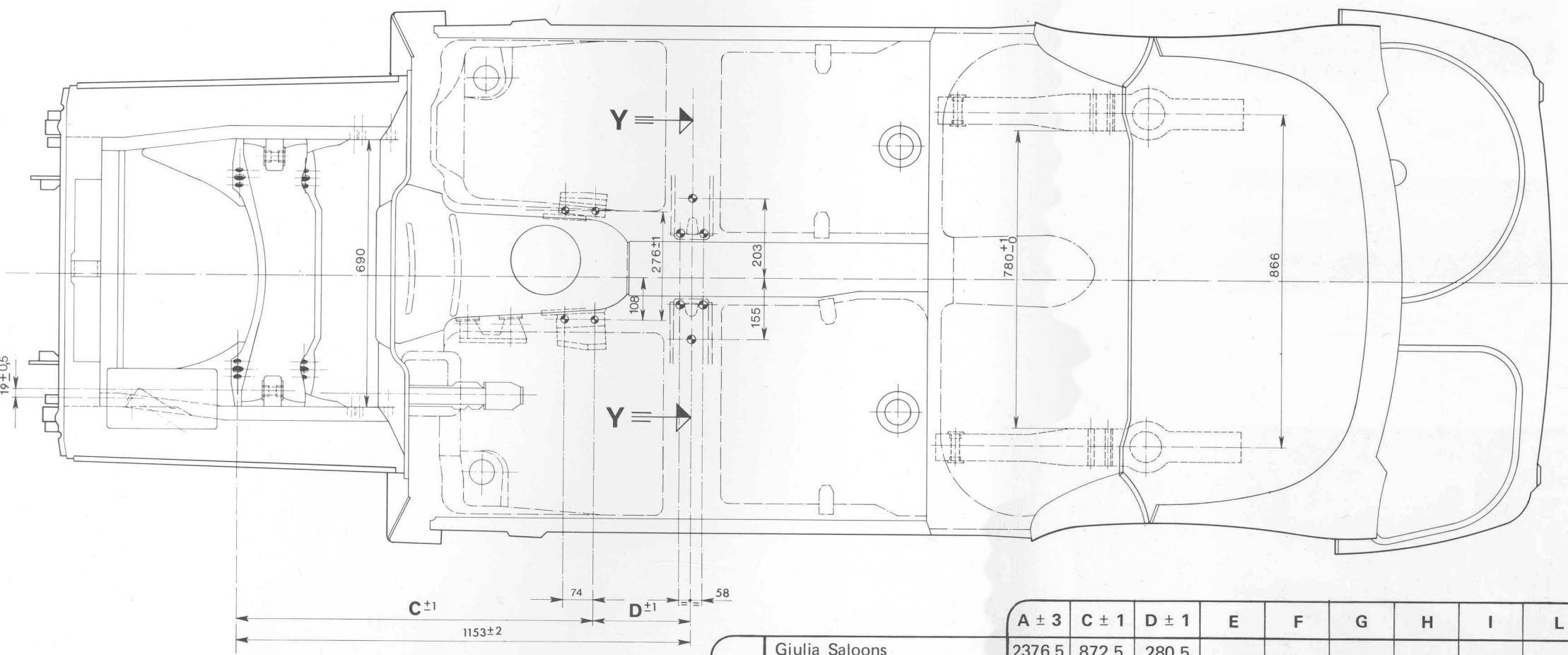
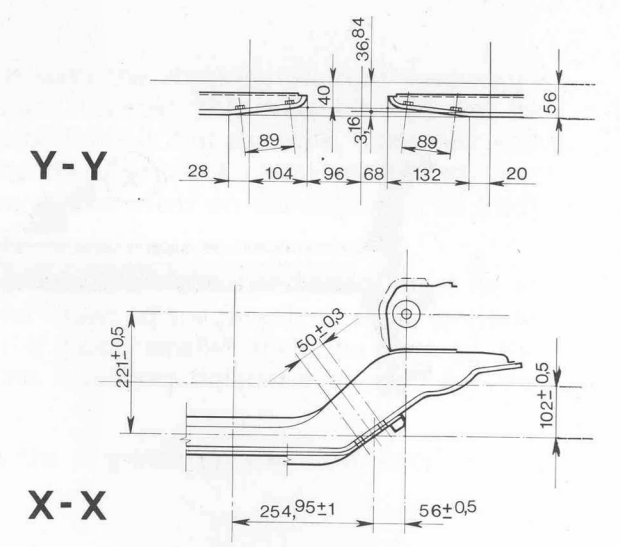
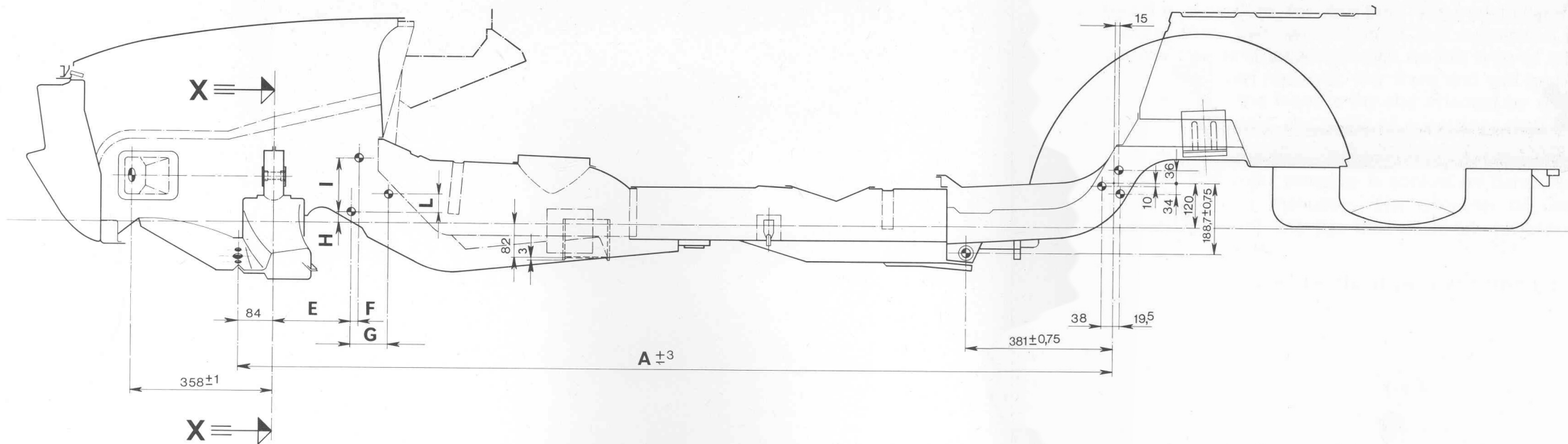

DIAGRAM OF DIMENSIONS OF MAIN UNIT ATTACHMENTS



MODEL	A ± 3	C ± 1	D ± 1	E	F	G	H	I	L
Giulia Saloons	2376.5	872.5	280.5	187.9	25	98.5	30	133.9	74.6
1750 Saloon	2436.5	870	283						
Coupé 1300-1600	2216.5	872.5	280.5	190.5	34.2	101.25	33.25	131.75	70.5
Coupé 1750		909	244						
Spider 1300-1600	2116.5	872.5	280.5	190.5	34.2	101.25	33.25	131.75	70.5
Spider 1750		909	244						

Dimensions in millimetres

FRONT CROSS MEMBER REPLACEMENT

The same procedure applies to all models in this range.
Giulia Saloon is shown for example purpose.

For chipping off the spot welds use a pneumatic chisel with a suitable tip and proceed in such a way as to avoid stressing the structure; therefore, the use of a welding torch should be positively avoided. Moreover, care should be taken not to true edges or smooth out parts of sheet metal so that, on reinstalling the new component, any difficulty in fitting is prevented.

REMOVAL

- Remove the affected main units (engine, suspension, steering gear) and position the body on the bench.

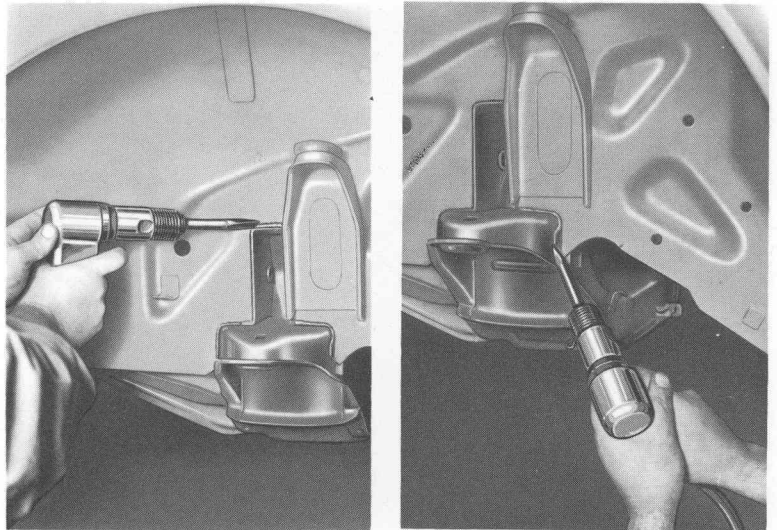

- Break off by chipping the spot welds joining the fender skirt outer panel and cross member.

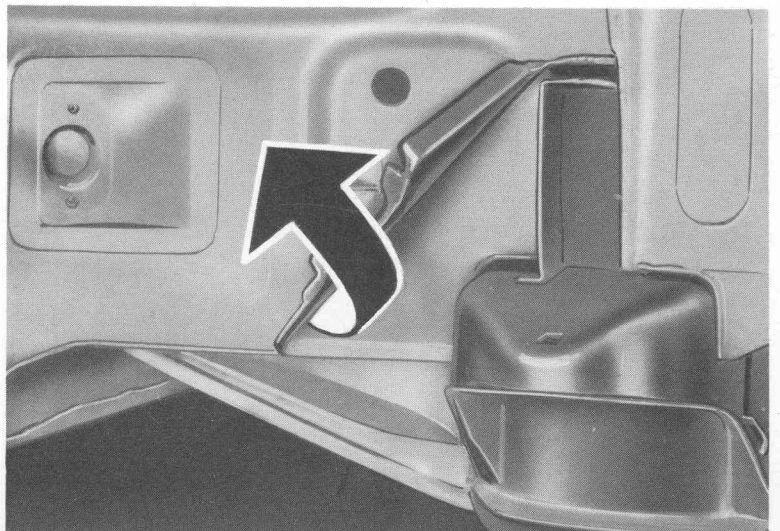

- With a suitable tool bend outward the skirt outer panel as shown.

FRONT CROSS MEMBER REPLACEMENT

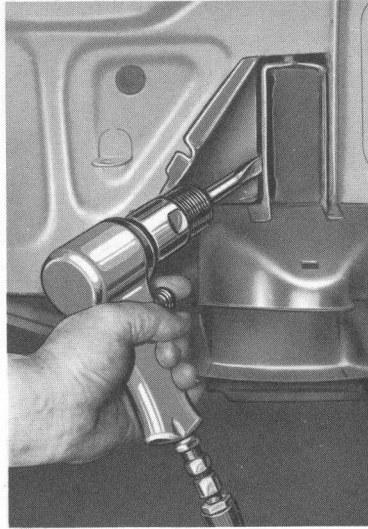

- Break off the seams between skirt inner panel and cross member through the opening so obtained.

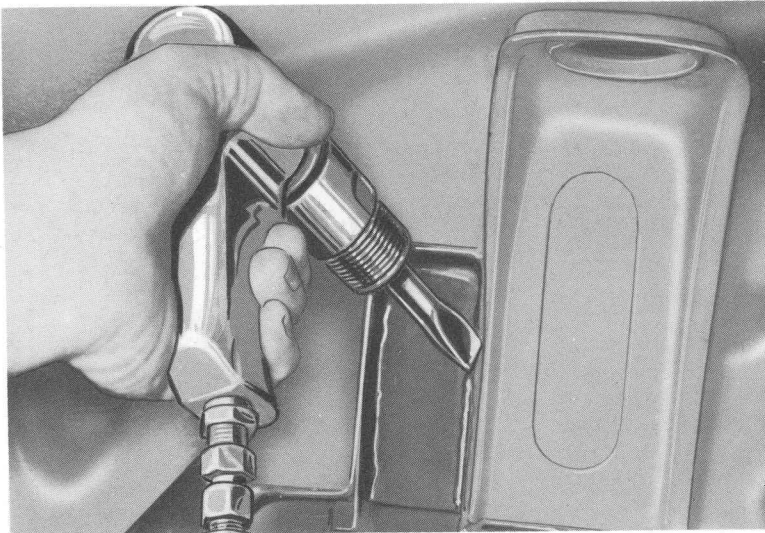

- Chip off the spot welds on skirt inner panel! (shock absorber mounting side).

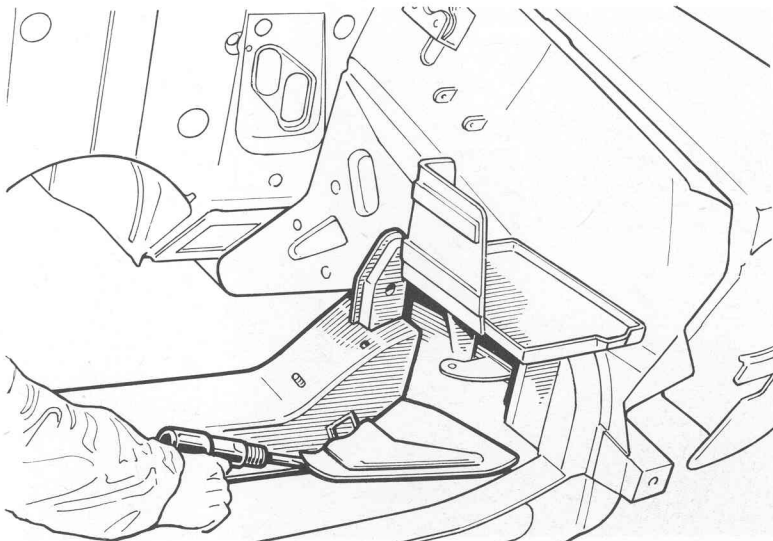

- From inside the engine compartment chip off the spot welds along the gusset.

FRONT CROSS MEMBER REPLACEMENT

- Start removing the cross member by tapping lightly with a mallet so as not to strain the adjoining structural components; then, take out the cross member by raising the body.

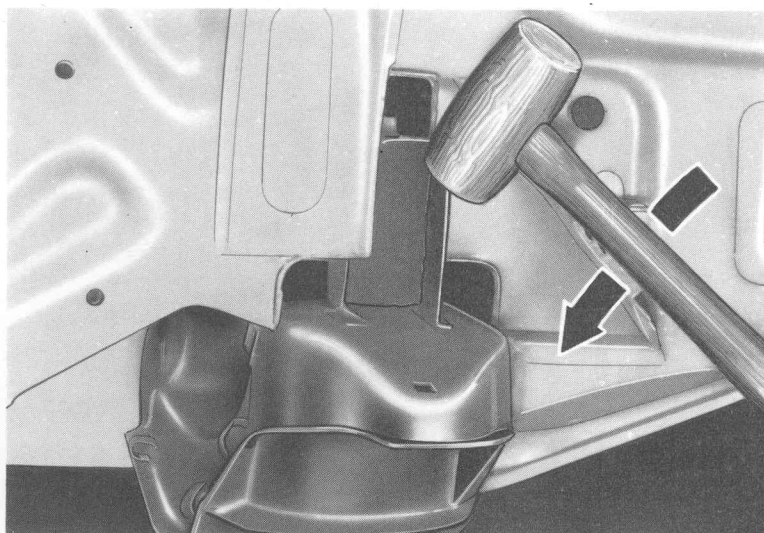

REINSTALLATION

- Cut the opening A in the shock absorber mounting.
- Place the new cross member on the positioning fixture and secure in place.
- Lower the body on the frame alignment checking bench.
- Check for the proper fitting of cross member with fender skirt panels.
- Secure the cross member to the body with clamps and spot welding; then, take away the positioning fixture.

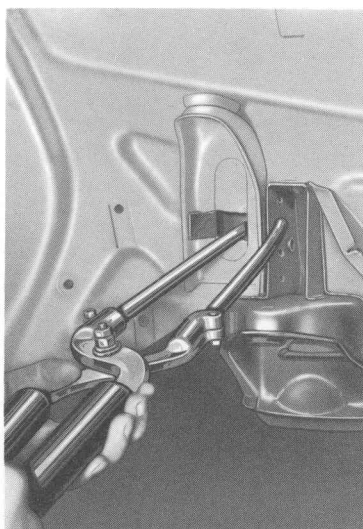
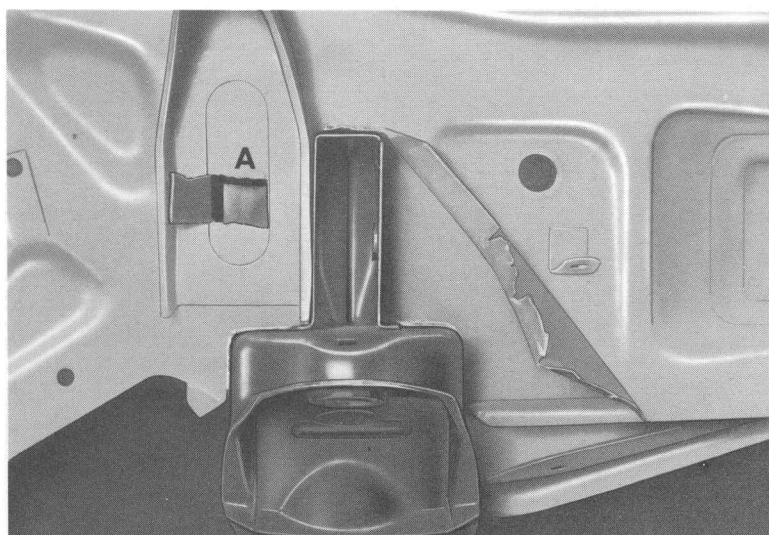

- Spot weld as shown through the opening A previously made.

FRONT CROSS MEMBER REPLACEMENT

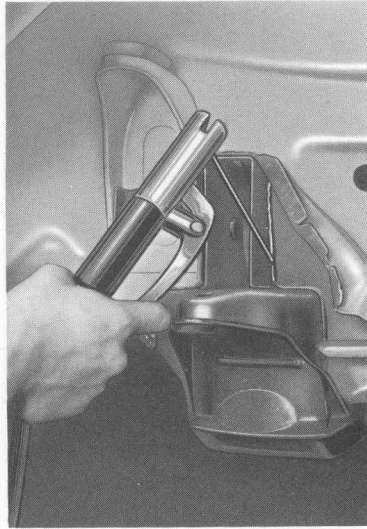

- Arc weld the bottom edges of skirt inner panel to the cross member.

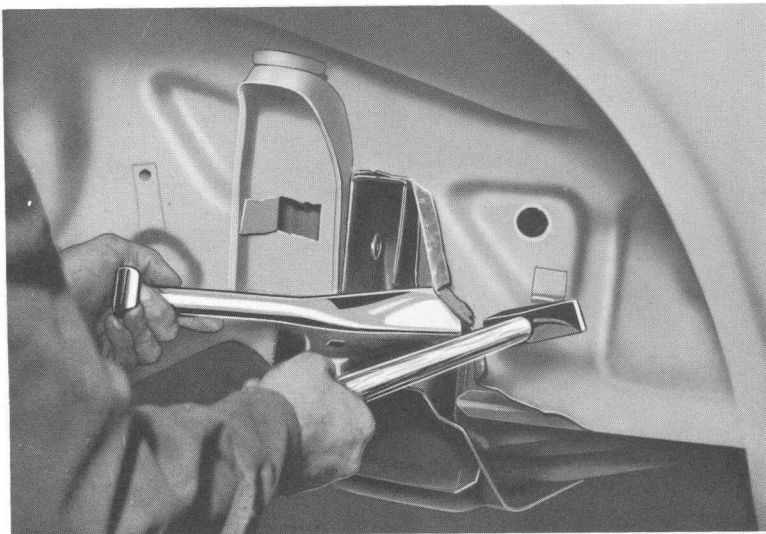

- With suitable tools, close the opening in skirt outer panel as shown.

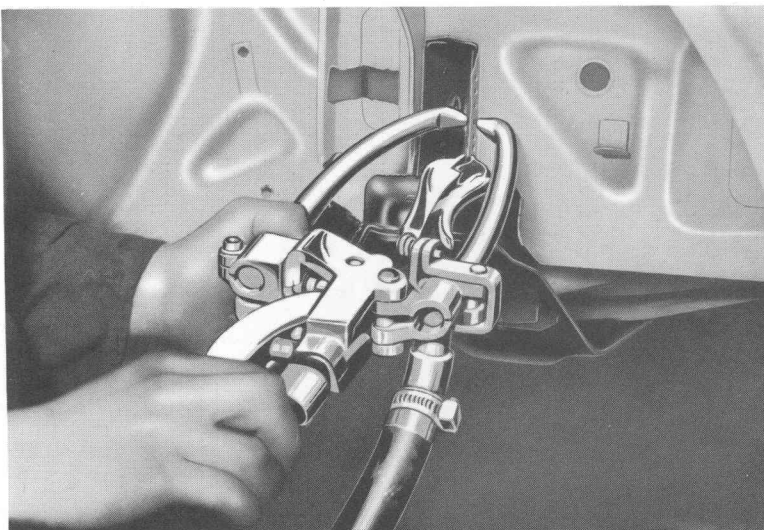

- Clamp properly the edges of skirt panel to the cross member.
- Spot weld the edge of skirt panel to the suspension arm attachment.

FRONT CROSS MEMBER REPLACEMENT

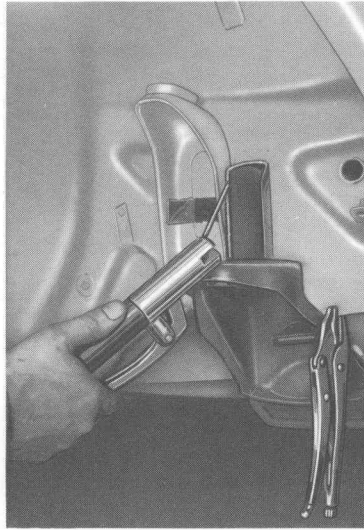

- Complete the arc welding of the remaining skirt panel edges.

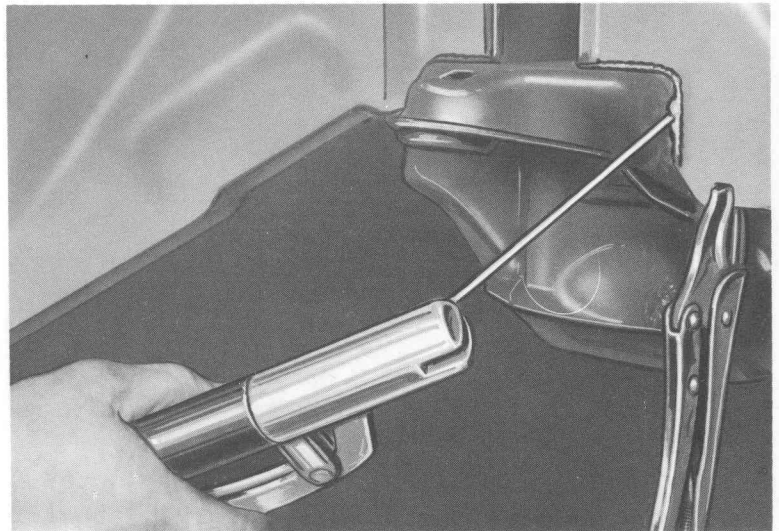

- Secure in place the front gussets with suitable clamps and spot weld them to the cross member.
- Flatten and close by welding the openings previously cut through.

FRONT CROSS MEMBER REPLACEMENT

NOTE – On 1300 and 1600 models (Saloon, Coupe, Spider), when only the cross member requires replacement and the frame alignment checking bench is not available, it is possible to replace the cross member with the special fixture P.N. A.8.0109 following this procedure:

REMOVAL

- Take the cross member off as directed on pages 15 and 16.

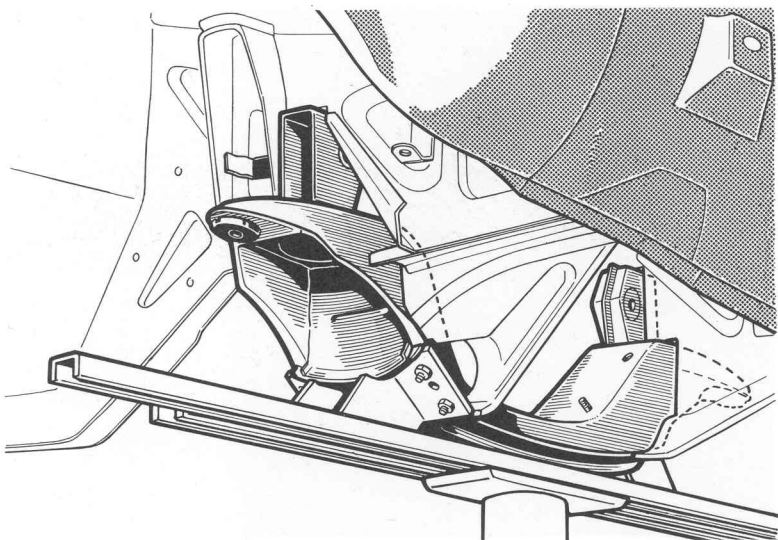

REINSTALLATION

- Place the new cross member on the fixture as shown and make it fit the body.

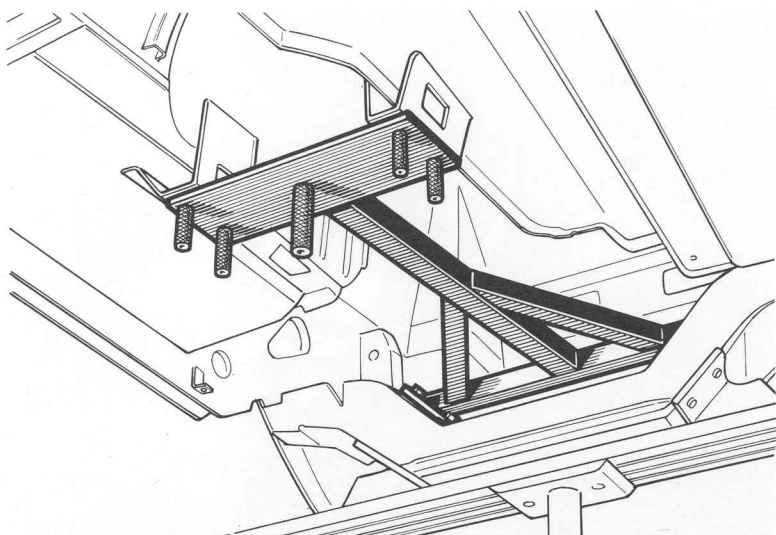

- Install the triangle-shaped part of the fixture and secure it to the engine mounts at the front and to the gearbox attachments at the rear.

FRONT CROSS MEMBER REPLACEMENT

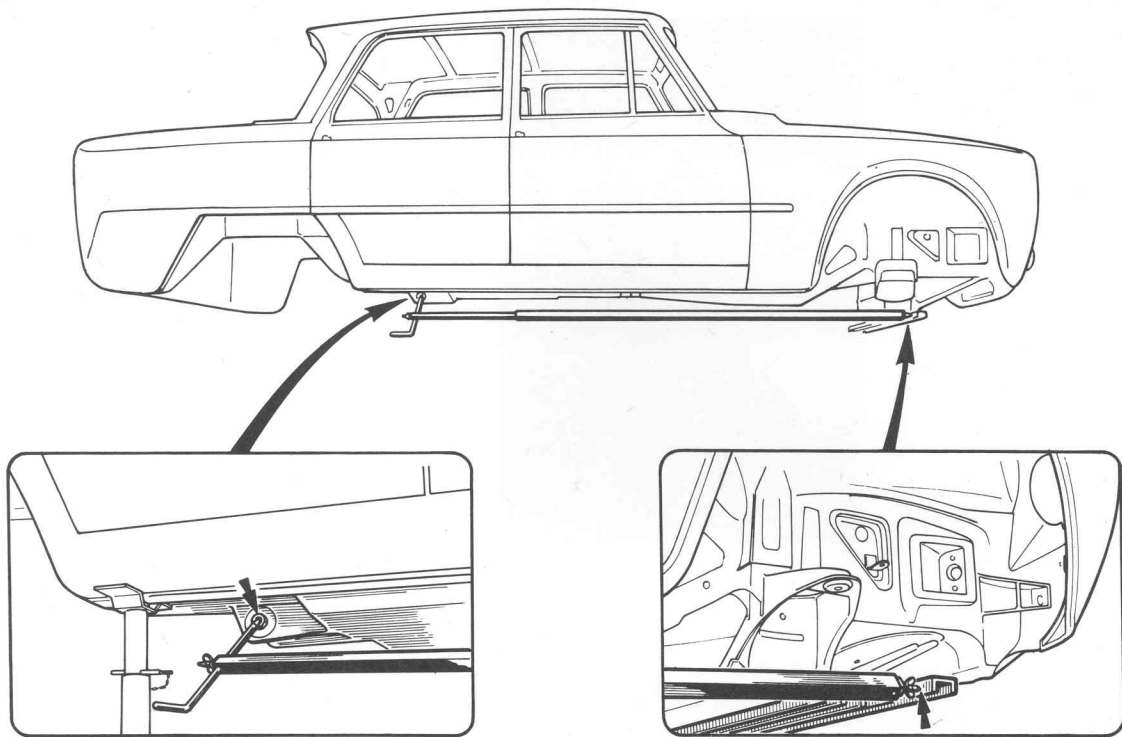

- Check the proper positioning of the cross member by using a frame gauge, taking measurements between the radius rod axis centerlines and the reference marks on the fixture as shown.

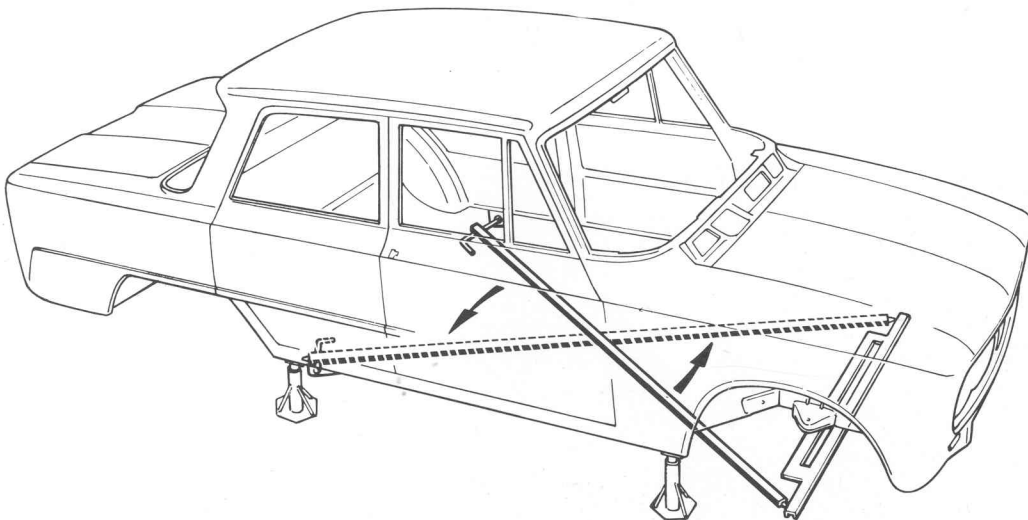

- After the above mentioned measurements have been performed, weld the cross member as directed under the chapter in which the installation by means of checking bench is covered.

REPLACING THE FENDER AND FRONT PANELS

The same procedure applies to all models in this range.
Giulia Saloon is shown for example purpose.

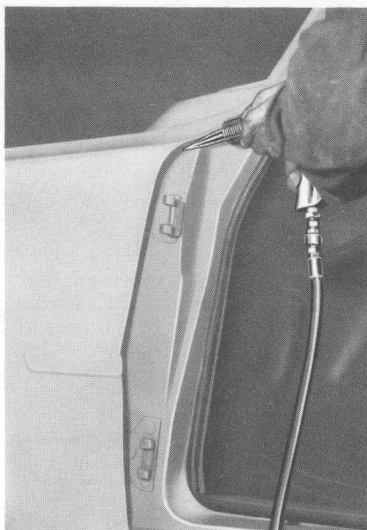

REMOVING THE FENDER

- Chip off and cut the seams joining the outer panel of fender with front pillar and skirt until the whole panel can be removed.

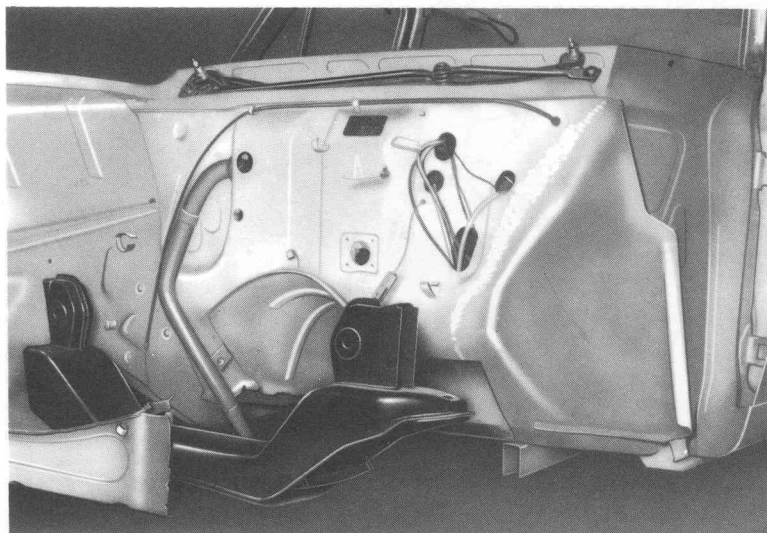
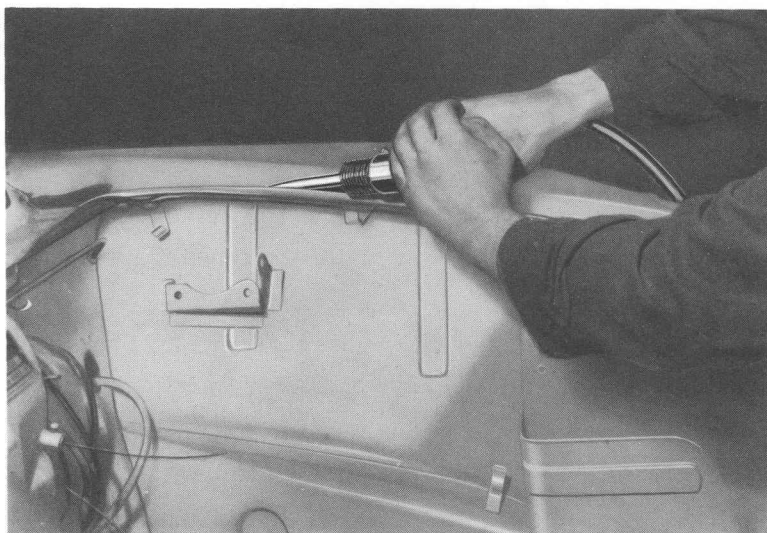

REMOVING SKIRT AND FRONT PANELS

- If even the front panels and the skirt require replacement, chip off their joining beads and take them away.

REPLACING THE FENDER AND FRONT PANELS

REFITTING THE SKIRT

Before refitting the skirt a careful checking must be made with the bench of the alignment of the other body components involved in the repair and specifically the front cross member either if it is renewed or merely reinstalled.

- Properly position the skirt inner panel.
- Place extension reference bar, special tool P.N. A.8.0056, between skirts (refer to page 13).



- Check that the skirt is properly positioned by taking measurements with a caliper between the cross member upper threaded hole and the corner made by the opposite skirt with the smaller cross piece at the front.

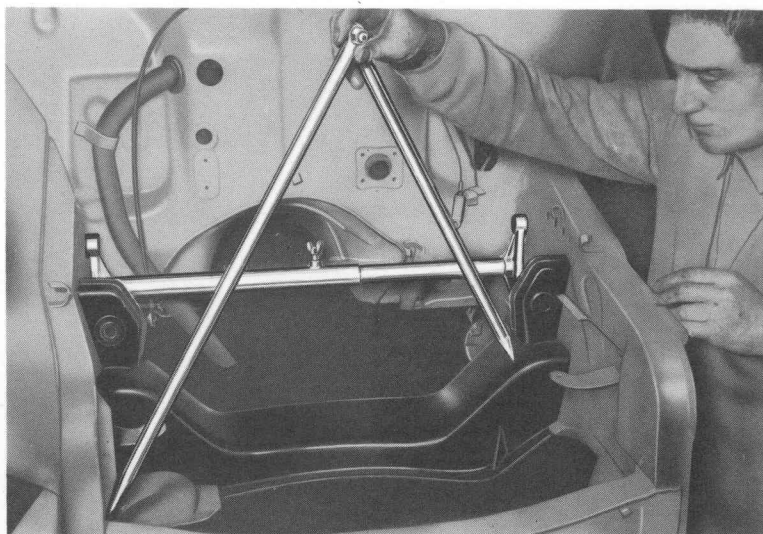

REPLACING THE FENDER AND FRONT PANELS

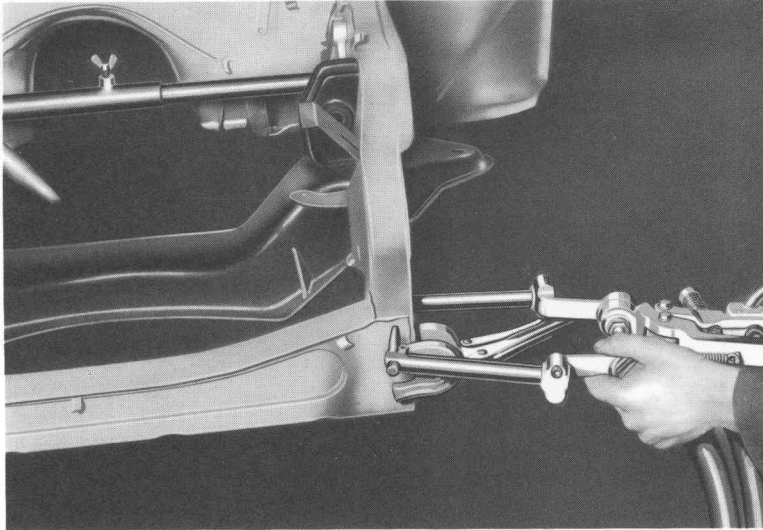

- Secure the skirt in place clamping together the panel edges.
- Spot weld the skirt to the cross piece.

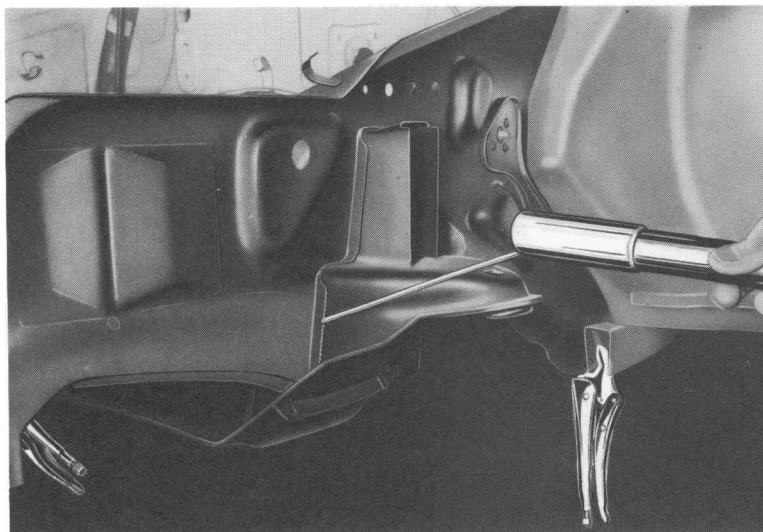

- Arc weld the skirt to the cross member and to the body panels.

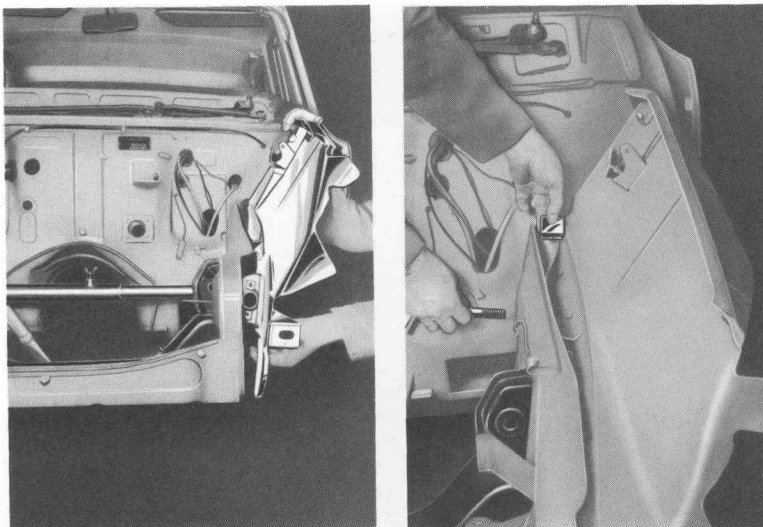

- Properly position the skirt outer panel
- Temporarily remove the extension reference bar, special tool P.N. A.8.0056, so as to free the holes.
- Insert between the skirt panels the two spacers for reinforcing the steering box attachment holes.
- Again install the extension reference bar special tool P.N. A.8.0056.

REPLACING THE FENDER AND FRONT PANELS

- Spot weld together the front edges of skirt inner and outer panels.
- With extension electrodes spot weld the remaining edges.

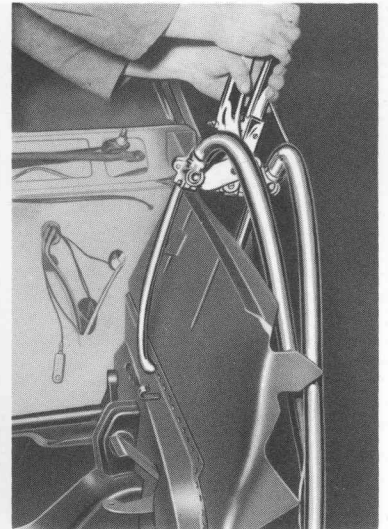
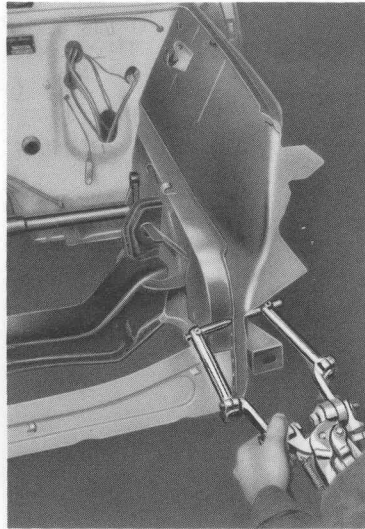

- Arc weld the skirt panels to the cross member and body.

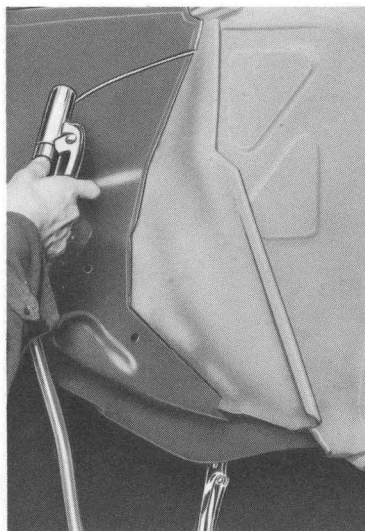

- At the front, position and secure in place with suitable clamps the skirt bottom panel, then spot weld the panel.

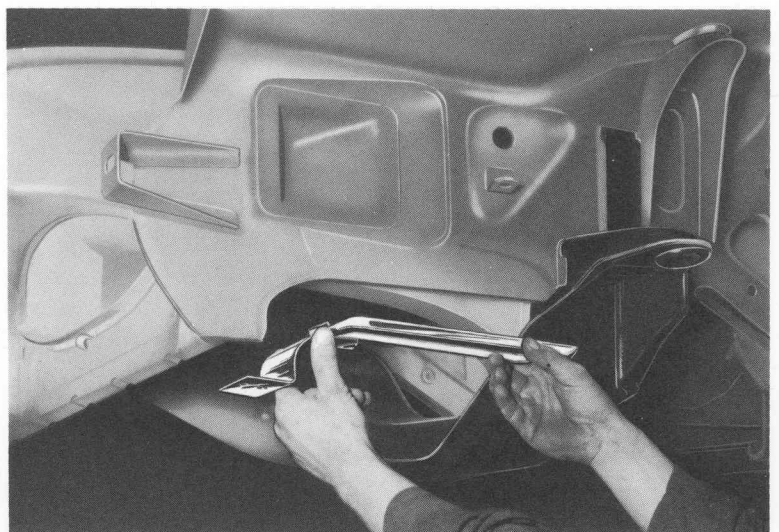

REPLACING THE FENDER AND FRONT PANELS

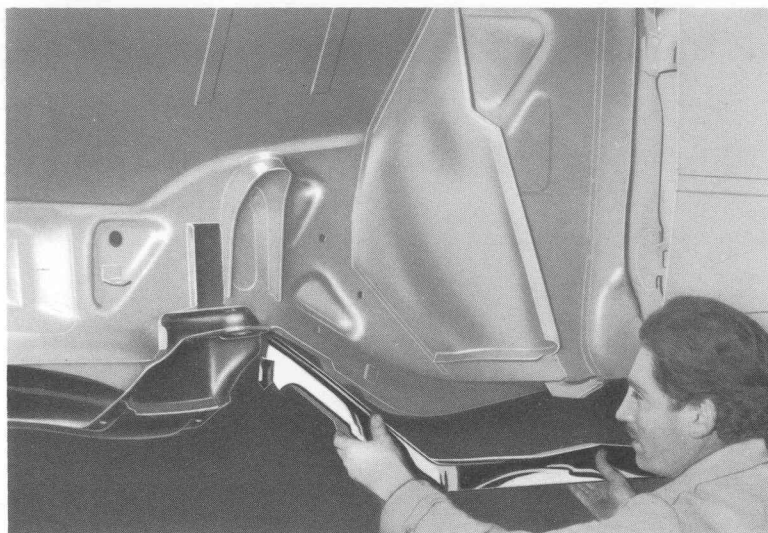

- At the rear, position and secure in place with suitable clamps the bottom reinforcement of skirt, then spot weld the reinforcement.

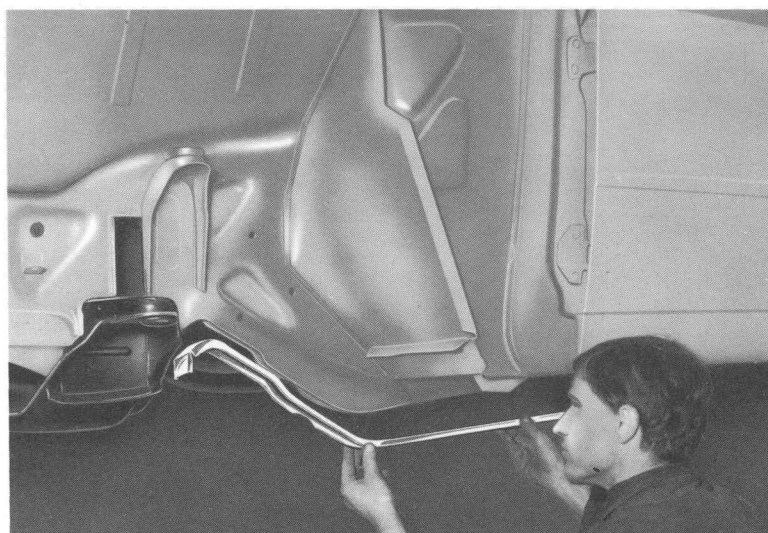

- Position and clamp in place the strip closing the reinforcement then spot weld the strip.

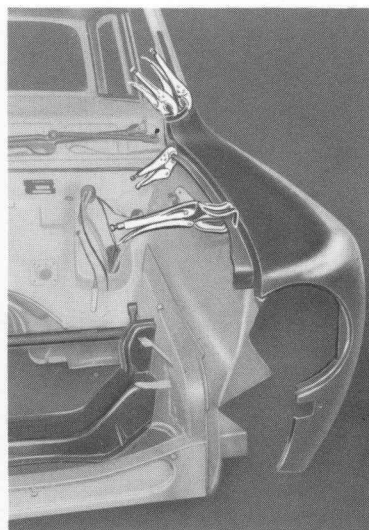

INSTALLING THE FENDER

- Position and secure the fender with clamps making sure it fits flush with the door and body contour.

REPLACING THE FENDER AND FRONT PANELS

- Spot weld the fender to the skirt and complete the joining of all parts by arc welding. The use of a welding torch is also allowed provided that special care is taken to prevent overheating.

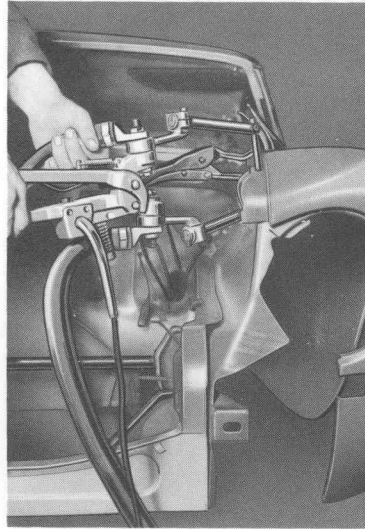

INSTALLING THE FRONT PANELS

- Position and secure in place the front panels then spot weld and sparingly arc weld.

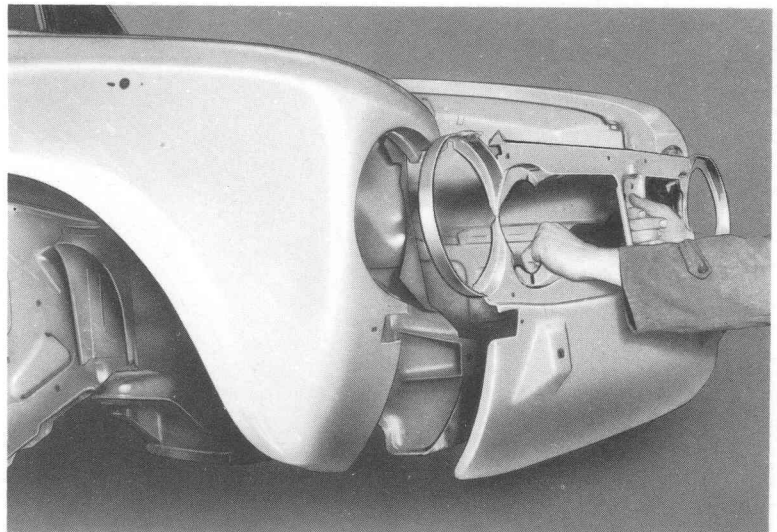

CAUTION – Before completing the welding, it is advisable to check the assembly with radiator grille and headlamp rims fitted.

BODY REPAIR

REPLACING THE TAIL PANEL

Coupe is shown for example purpose.

REMOVAL

- Cut and chip off the seams to remove the tail panel

INSTALLATION

- Position and secure in place the replacement panel with suitable clamps.

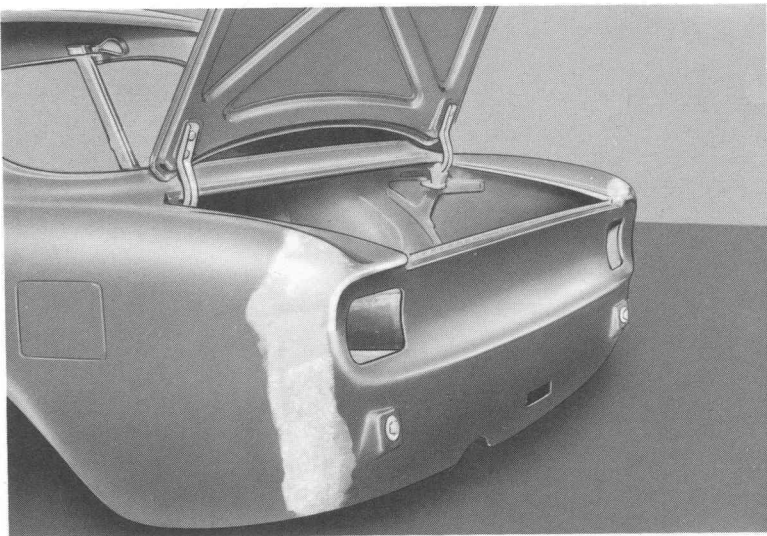

- Check that the panel is in proper alignment with the body and weld the edges to the fenders.

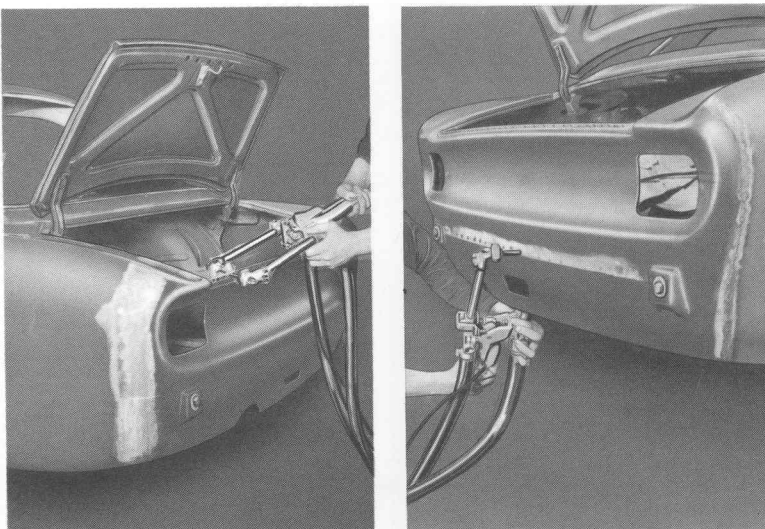

- Then spot weld the tail panel to the remaining structural components.

REPLACING THE REAR WING ASSEMBLY

Coupe is shown for example purpose.

NOTE – To make easier the replacement of the rear wing assembly, the whole replacement unit is available as spare.

REMOVAL

- Cut off the weld lines to remove the panels as a unit.

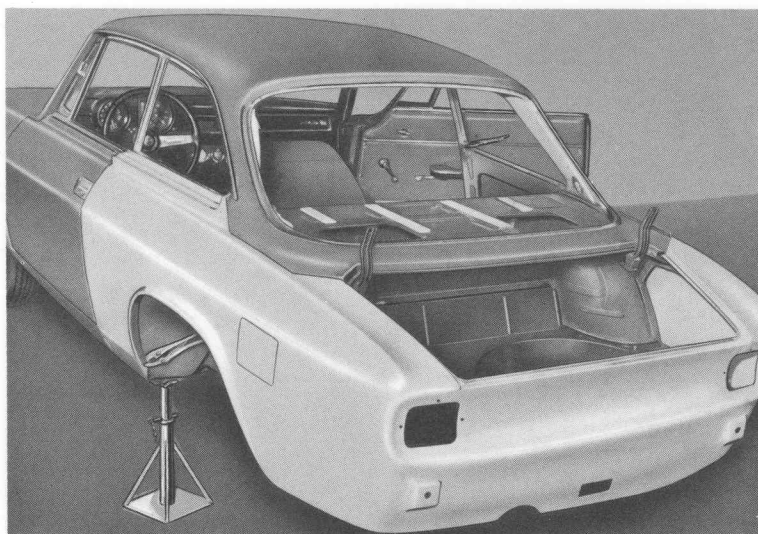
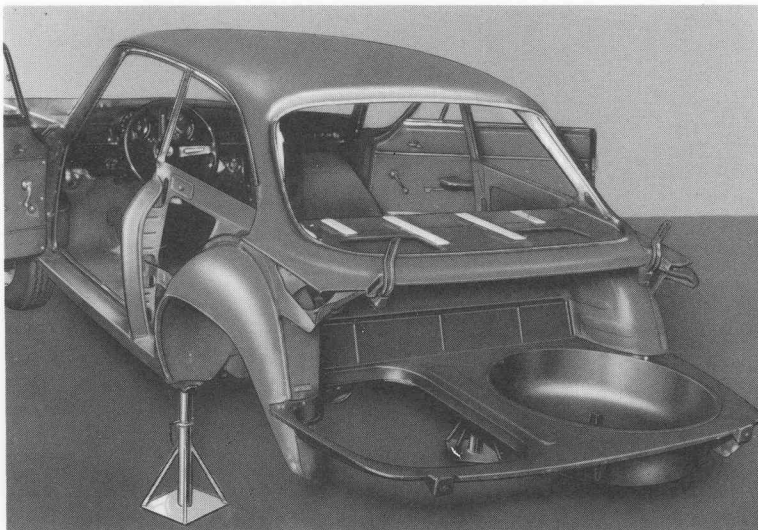

REINSTALLATION

- Position and clamp in place the new wing assembly.

- Carefully check for proper alignment with the body, then spot weld the sheet metal.

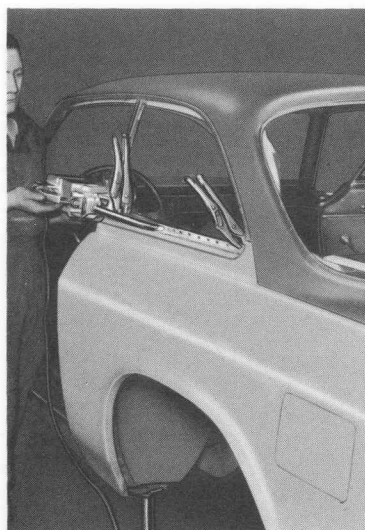

BRINGING WINDSCREEN FRAME BACK INTO SHAPE

The same procedure applies to all models in this range. Giulia and 1750 Saloon are shown for example purpose.



The same procedure applies for realigning the frame of both the windscreen and the rear window.

- With the extension gauge A.8.0112 check that measurements taken diagonally as shown have the same value.

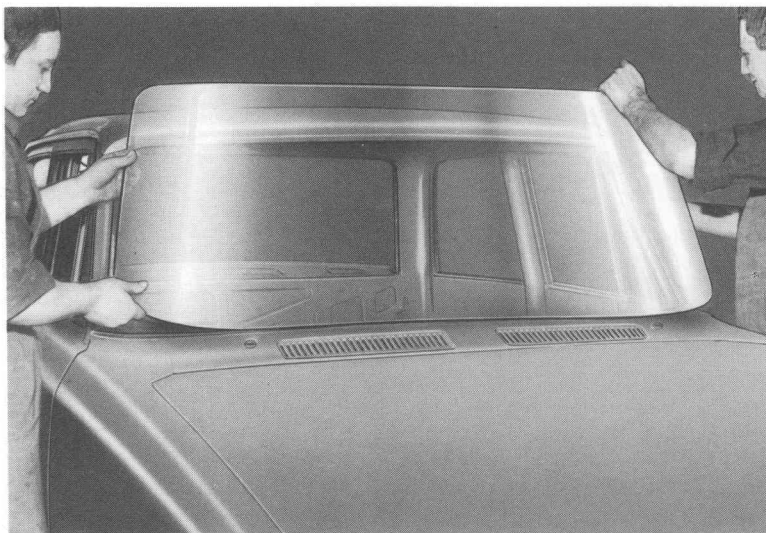

- Try positioning the glass on the frame so as to check whether they fit properly.

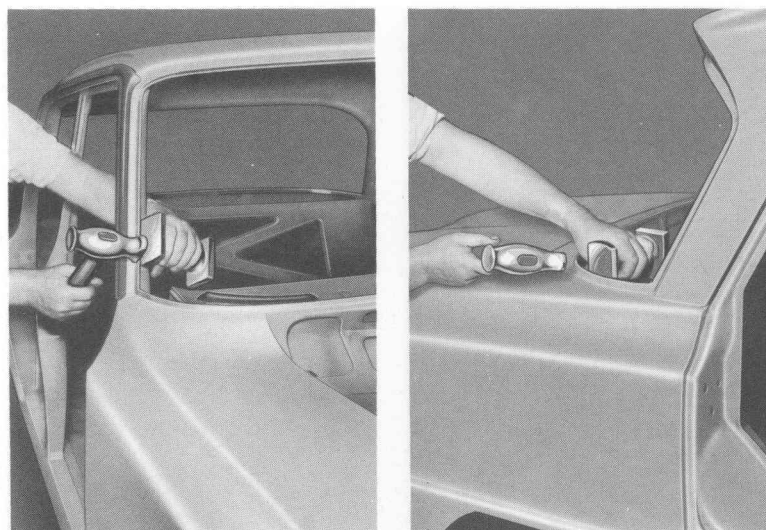

- If needed, bring back into shape the weatherstrip mounting lip with a hammer and dolly block.

WINDSCREEN AND REAR WINDOW GLASS

The same procedure applies to all Saloon and Coupe models.
Giulia and 1750 Saloon are shown for example purpose.

Proceed the same way both for the windscreen and the rear window.

REMOVAL

- Take the corner finishers away of the mouldings.

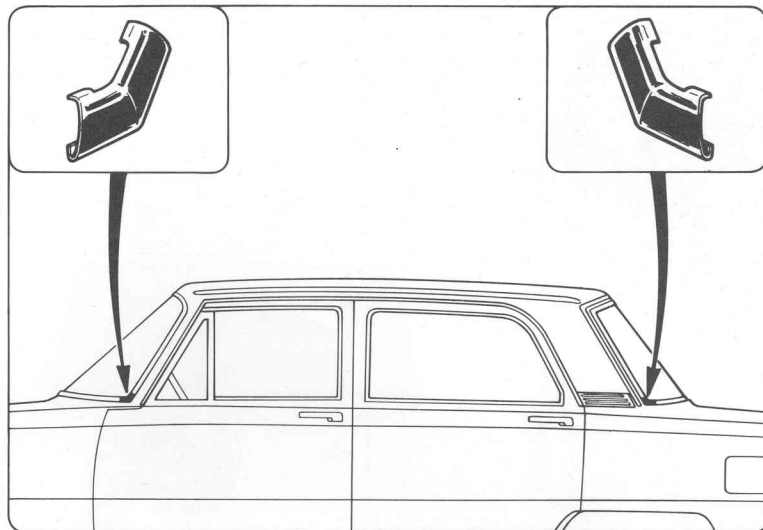

- From inside out, apply pressure evenly distributed on the glass; from the outside, have an assistant holding the glass when it pops out of weatherstrip.

To make the windscreen removal easier, cut the inner lip of weatherstrip with scissors; in this case the weatherstrip must then be renewed.

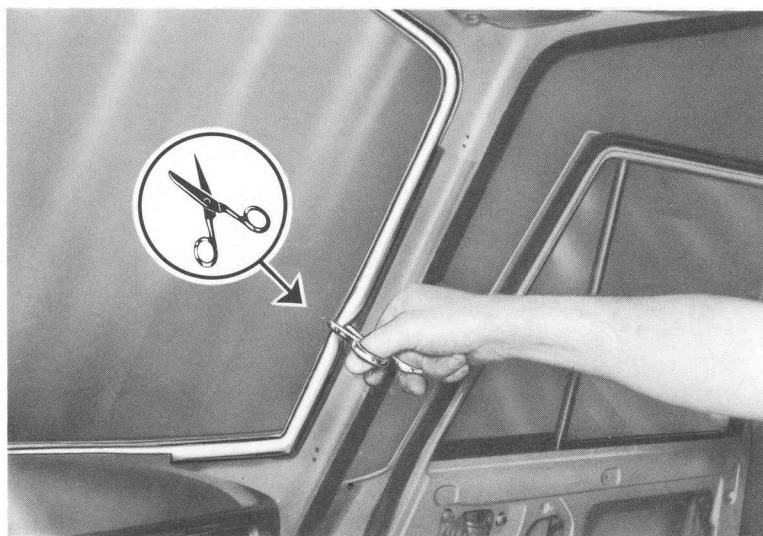

INSTALLATION

- 1 – Carefully clean the edges of the glass and install the weatherstrip on it.

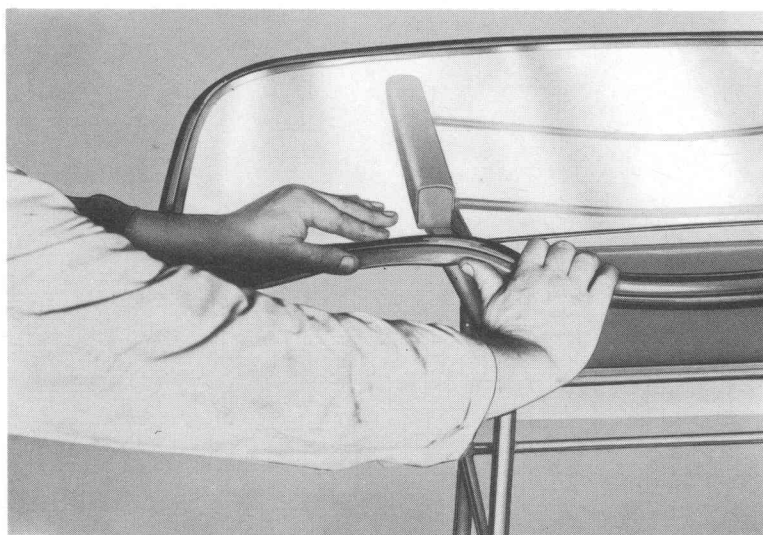

WINDSCREEN AND REAR WINDOW GLASS

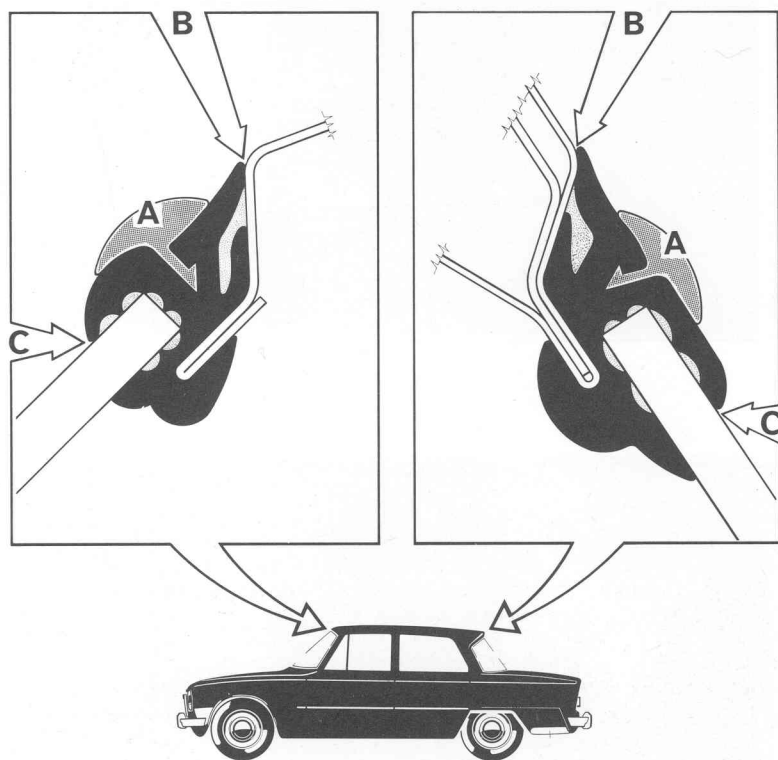

- 2 – In order to facilitate the installation of the metal moulding A, spray liquid soap to lubricate the weatherstrip.

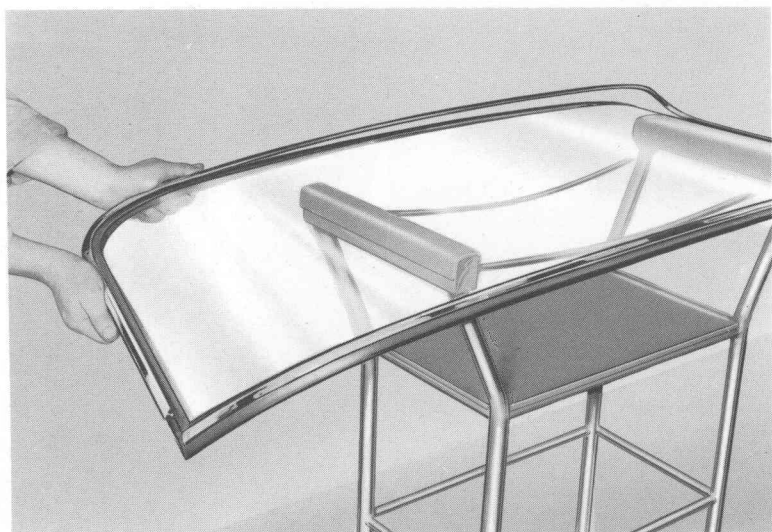

- 3 – Install the metal moulding.

NOTE – The operations 1-2-3 are to be carried out when the weatherstrip needs replacement.

To perform these operations it is advisable to rest the glass on the suitable stand P.N. A.9.0104.

WINDSCREEN AND REAR WINDOW GLASS

- Wrap two cords EE–FF around the outer groove D of weatherstrip as shown.

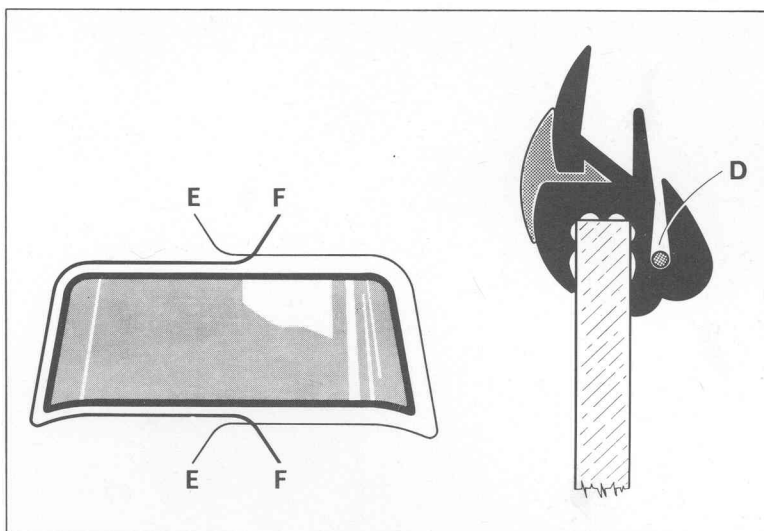

- Lay a bead of petroleum jelly around the glass opening for ease of installation.



- Place the glass in the opening.

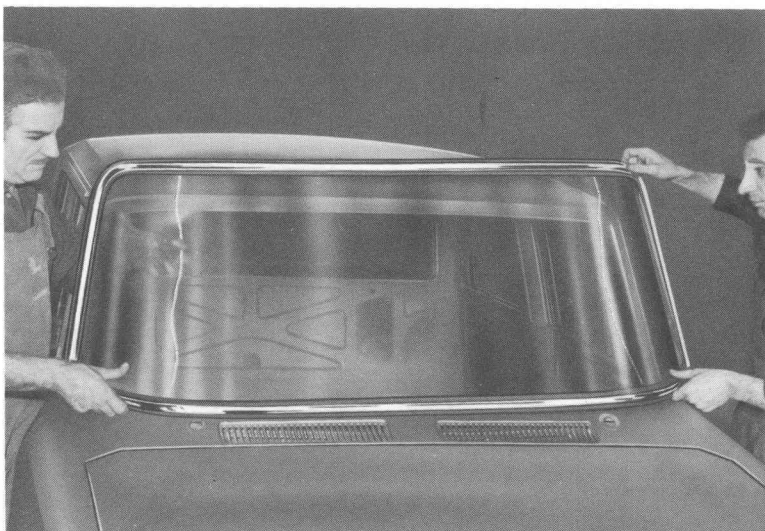

WINDSCREEN AND REAR WINDOW GLASS



- From the outside apply pressure over the glass.

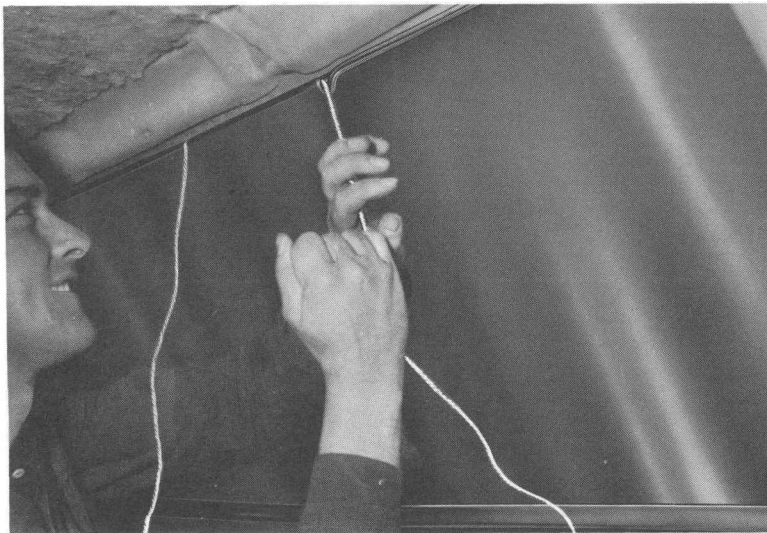

- At the same time, an assistant, pulling from the inside the ends of the cords one at a time, will facilitate the seating of weatherstrip into the glass opening.



- Tap lightly with the hand on the glass especially in the corners.

WINDSCREEN AND REAR WINDOW GLASS

- Insert the spout of the gun under the weatherstrip lips B and C as shown in the illustration on page 32 and apply the specified sealing compound.



- Refit the corner finishers and secure them in place with the pliers, special tool P.N. A.9.0035

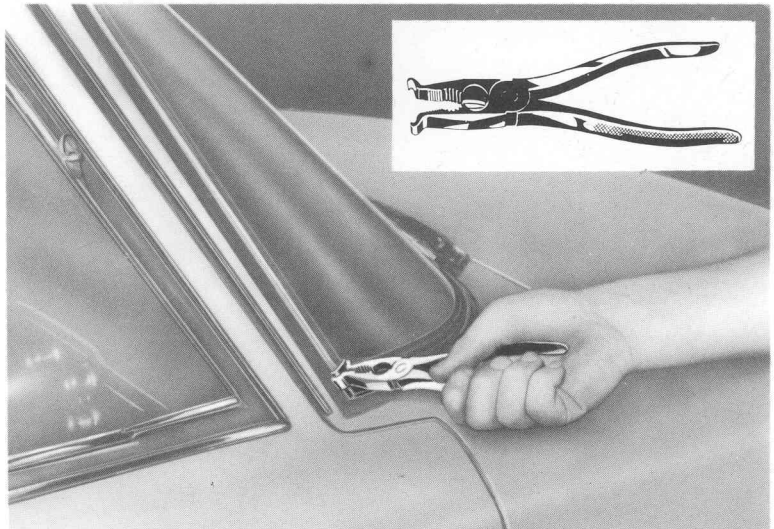

NOTE – Should the weatherstrip show sign of defect which might impair the waterproofing of the windscreen, it must be changed with a new one.

The perfect sealing against water leaks depends upon the way the above mentioned procedure is performed especially as far as care in applying the sealing compound is concerned.

REMOVAL AND INSTALLATION

DOORS

The same procedure applies to all Saloon models.
1750 Saloon is shown for example purpose.

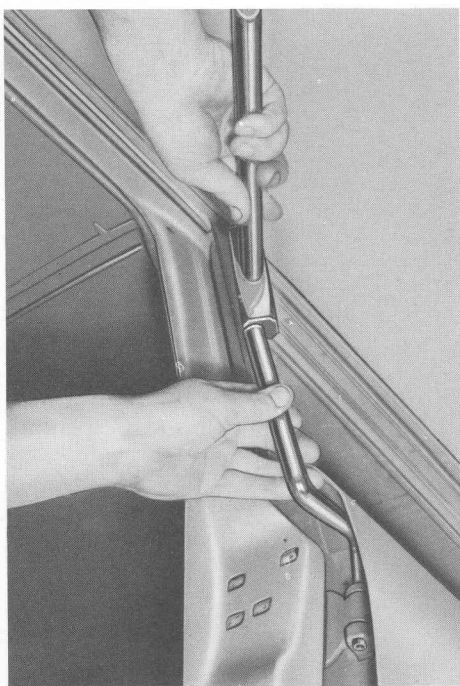
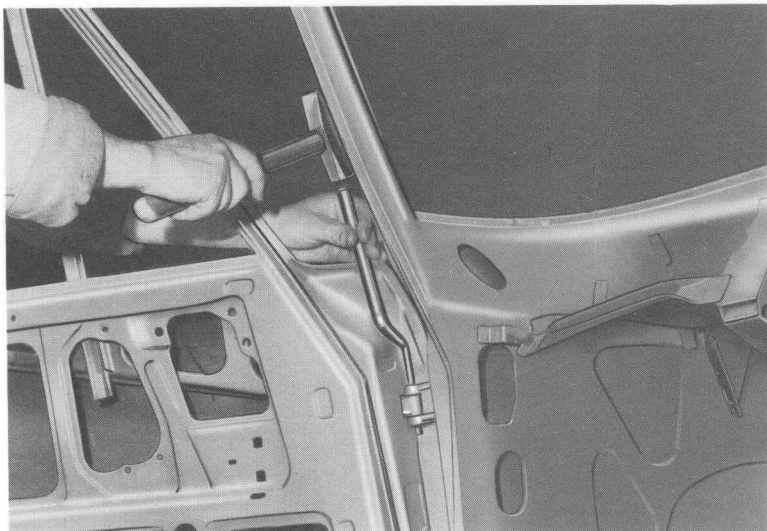

REMOVAL

- Remove the spreader plug and withdraw the hinge pins by tapping lightly with a hammer on a suitable punch which can be easily manufactured or purchased locally. Start from the lower hinge. Hold the door when the hinge pin slips out of the upper hinge.

NOTE – To gain access to the hinge pins of rear doors, open up the front doors.

INSTALLATION

Reverse the removal procedure.

NOTE – If the doors are out of alignment, any adjustment should be made by acting only on the adjustable hinges. To prevent shortening the life of the hinge pins never put the doors under undue strains even by hand.

DOOR TRIM PANELS

1750 Saloon is shown for example purpose.

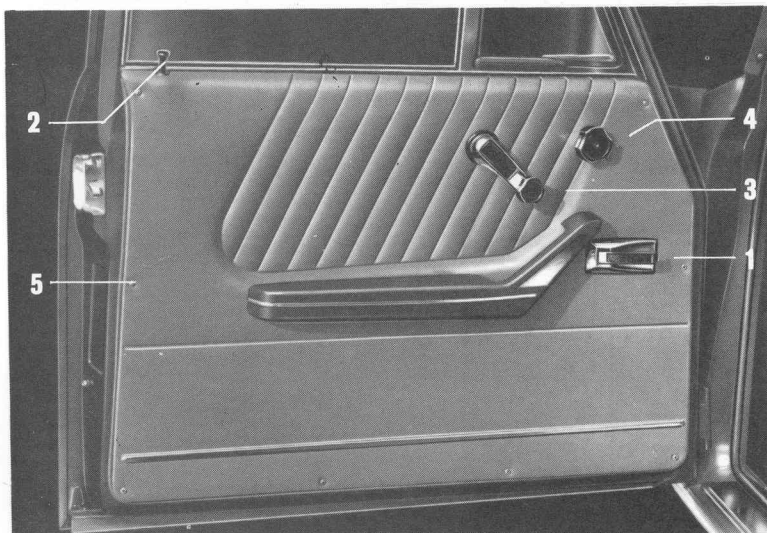

REMOVAL

- Take the safety lock button 2 out by unscrewing it.
- Remove the remote control handle support 1, the window regulator handle 3, the vent window knob 4 (front doors) by unscrewing the attaching screws.
- Take the trim panel away by loosening the attaching screws 5.



- Detach the plastic sheet as shown.

INSTALLATION

Proceed in reverse order of removal.



REMOVAL AND INSTALLATION

DOOR GLASS FRAMES

The same procedure applies to all Saloon models.
1750 Saloon is shown for example purpose.



REMOVAL

- Start removing the upper frame of door glass by tapping lightly with a mallet and a wooden block at the sides as shown.

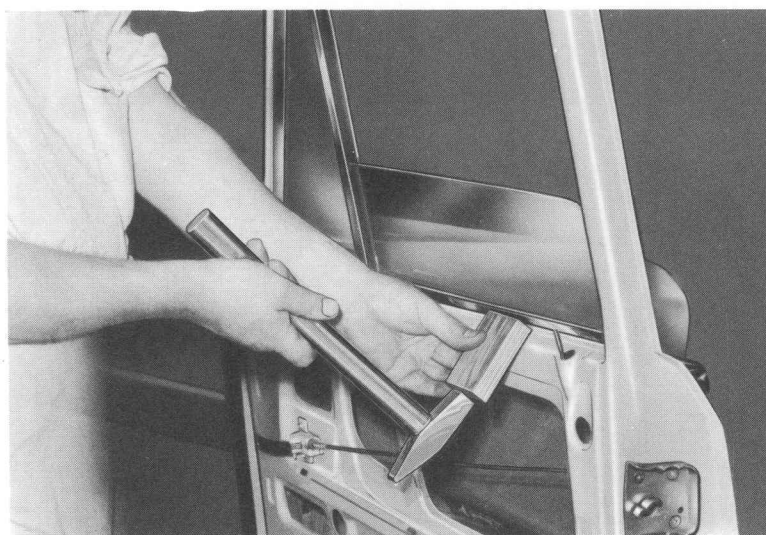

- Remove the lower frame in the same way as outlined above.

INSTALLATION

Slide into position the lower frame first, then the upper frame and push them in place by applying even pressure.

DOOR LOCKS

1750 Saloon is shown for example purpose.

FRONT DOOR LOCKS

REMOVAL

- Remove the door trim panel and detach the plastic sheet (see page 37).
- Loosen the two screws securing the support of remote control handle.

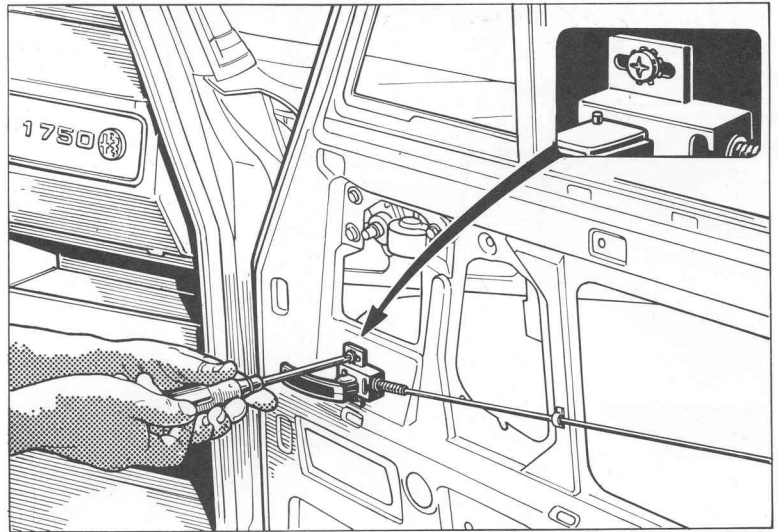

- Pry out of its seat the remote control rod guide.

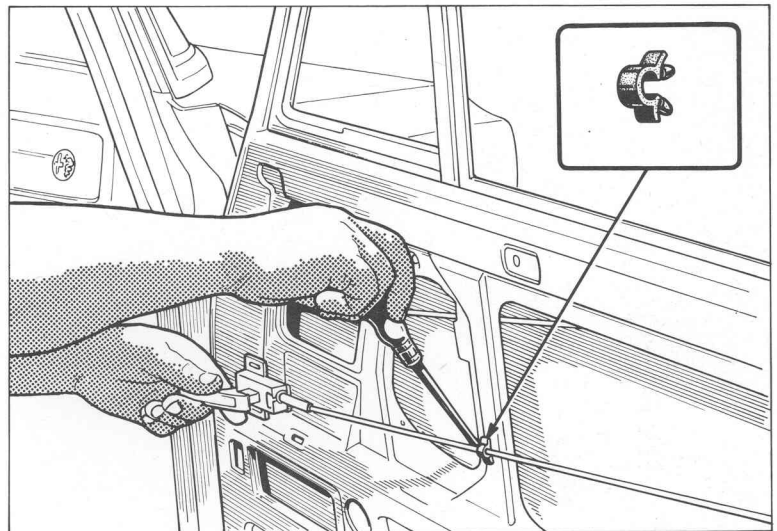

- Disconnect the outside handle-to-lock link.

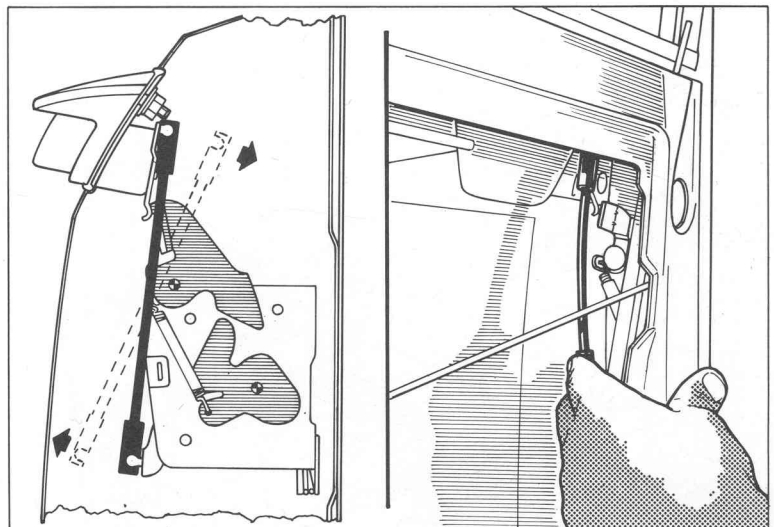

DOOR LOCKS

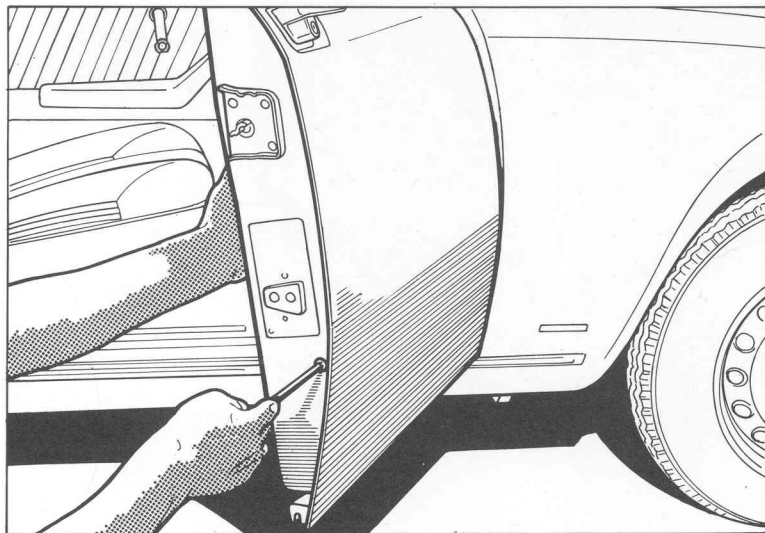

- Unscrew the attaching screws and remove the glass run channel.

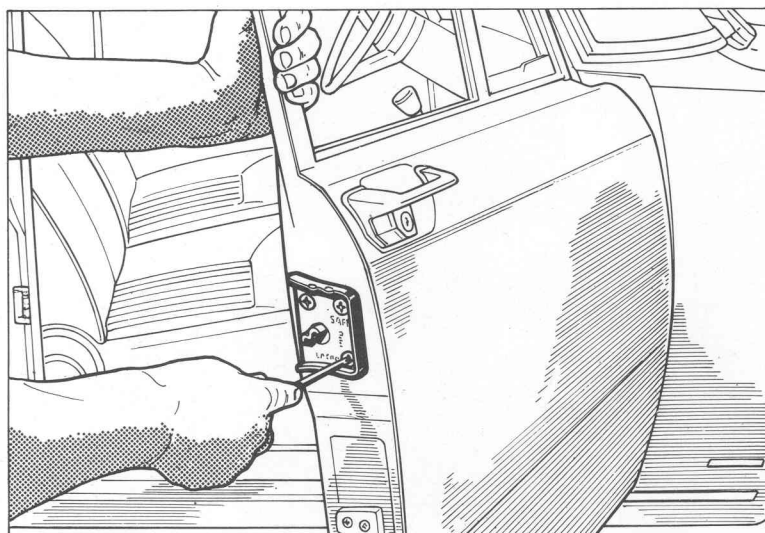

- Remove the screws securing the dovetail and take the dovetail away.

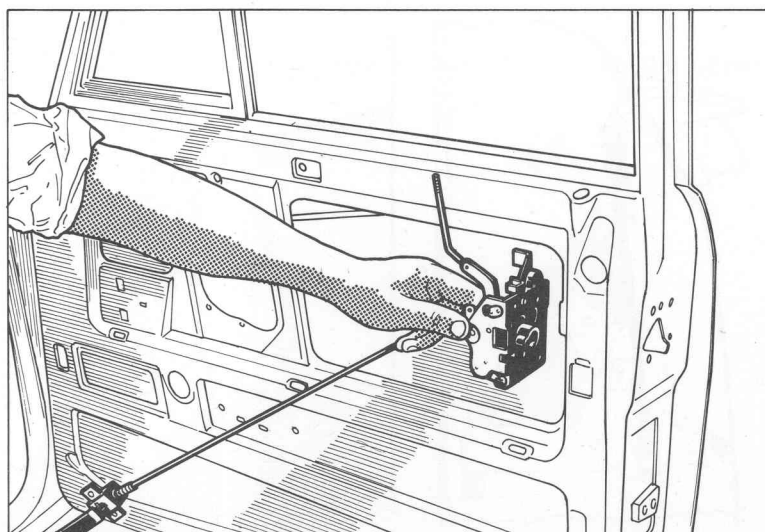

- Remove the remote control rod and the lock as a unit.

INSTALLATION

Reverse the removal procedure.

DOOR LOCKS

REAR DOOR LOCKS

REMOVAL

- Remove the door trim panel and detach the plastic sheet (see page 37).
- Remove nut and washer securing the support of remote control rod and safety button.

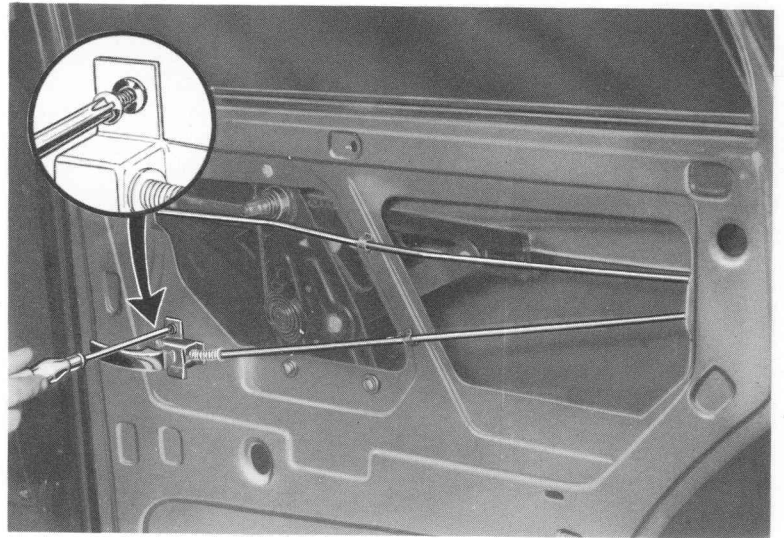
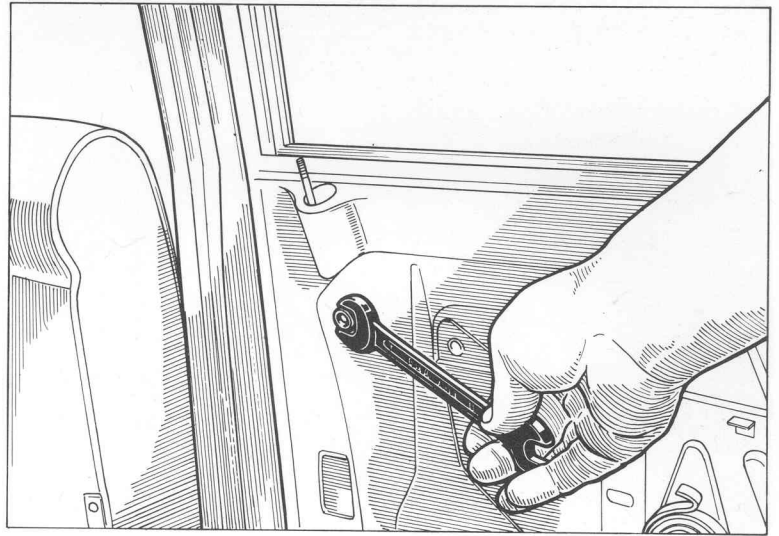

- Remove the screws securing the support of remote control handle.

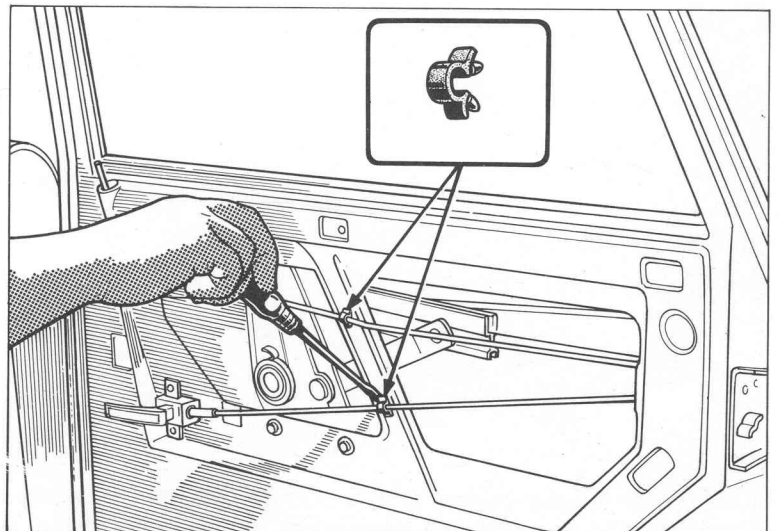

- Pry out of their seats the guides of remote control rods of door locks and safety catch.

REMOVAL AND INSTALLATION

DOOR LOCKS

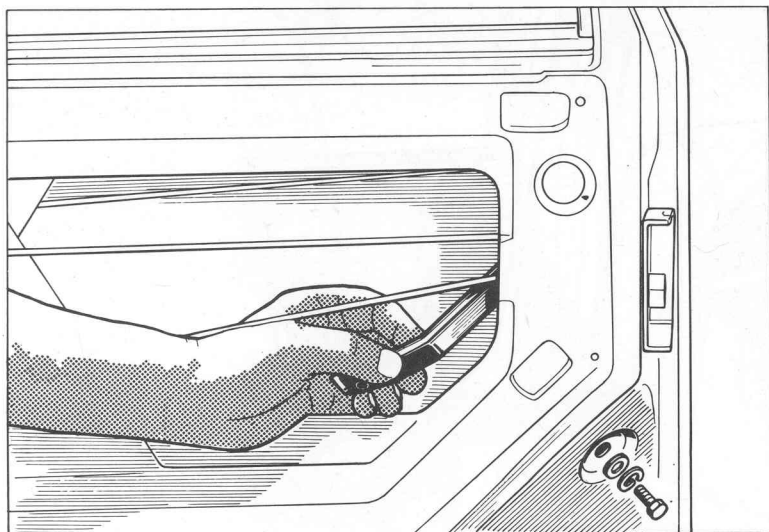

- Remove the securing screw and withdraw the rear glass channel.

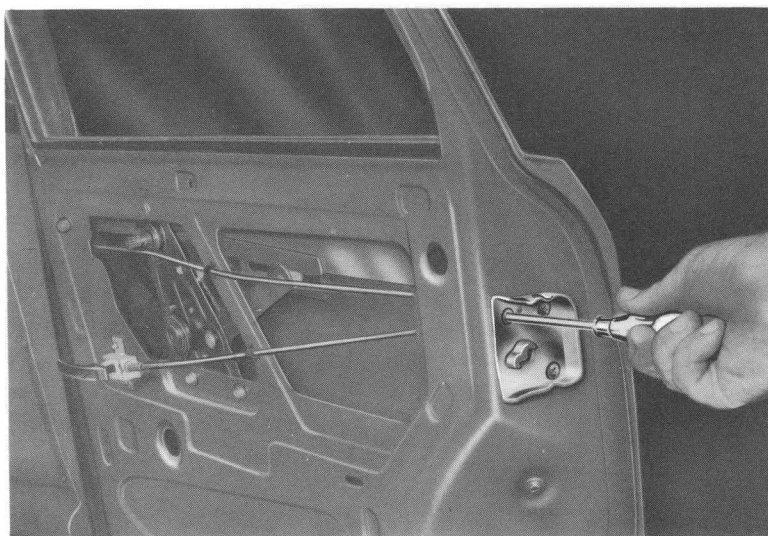

- Remove the screws securing the dovetail and take the dovetail away.

- Remove the lock, the remote control rod and the safety catch rod as a unit.

INSTALLATION

Reverse the order of removal.

NOTE – On Giulia Saloon and all Coupe models the safety catch is controlled by the inside door handle; therefore, it is necessary to disconnect the related control link.

WINDOW REGULATORS

The same procedure applies to all models in this range.
1750 Saloon is shown for example purpose.

REMOVAL

- Remove the door trim panel and detach the plastic sheet (see page 37).
- Remove the screws securing the window regulator.

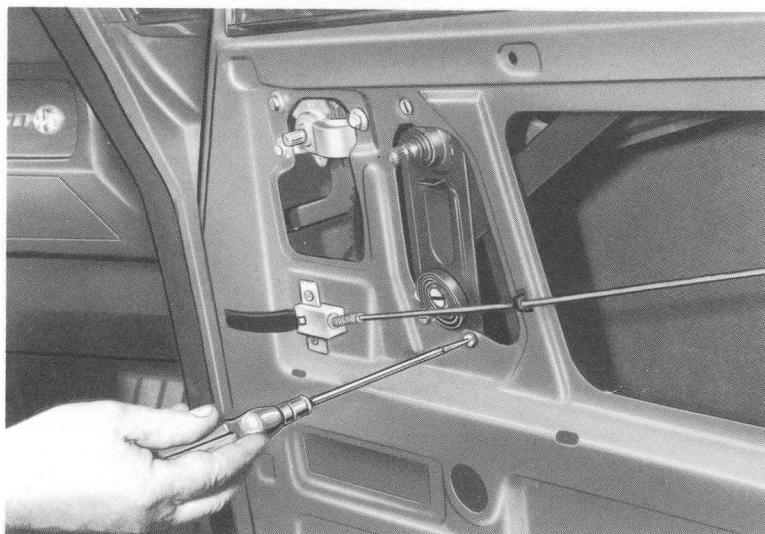

- With the handle, wind the regulator so that the end of the lever is positioned as shown in the glass support slot (the regulators at the rear have two levers).
- Disconnect the end of the lever from the glass support as shown (at the rear both levers should be disconnected).



- Push the glass upward.
- Take the window regulator out of the door frame.

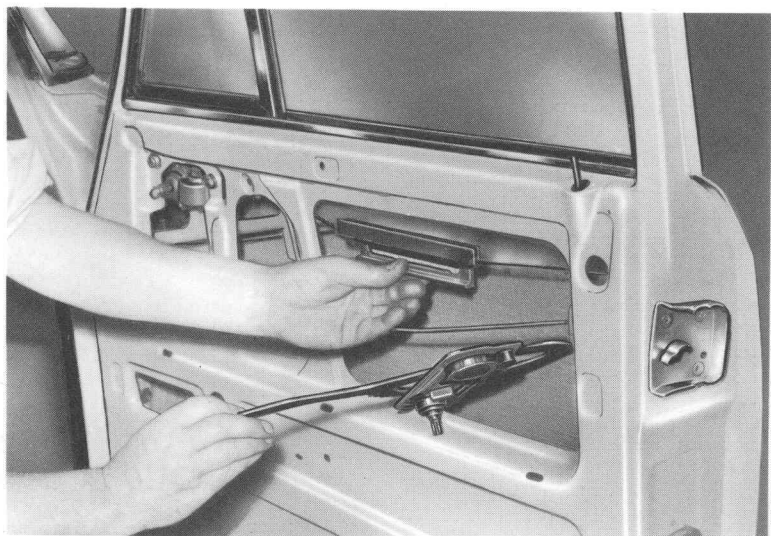

INSTALLATION

Reverse the order of removal.

DOOR GLASSES

The same procedure applies to all models in this range. Giulia and 1750 Saloon are shown for example purpose.

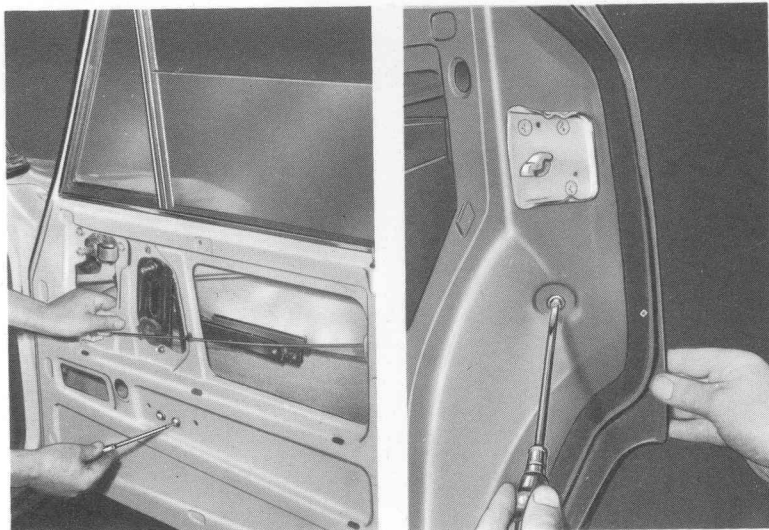

The operations are the same for the glasses of front and rear doors.

REMOVAL

- Remove the door glass frames (see page 38).
- Remove the door trim panel and detach the plastic sheet (see page 37).
- Remove the window regulator (see page 43).
- Remove the screws securing:
 - the front glass channel on front doors;
 - the rear glass channel on rear doors.

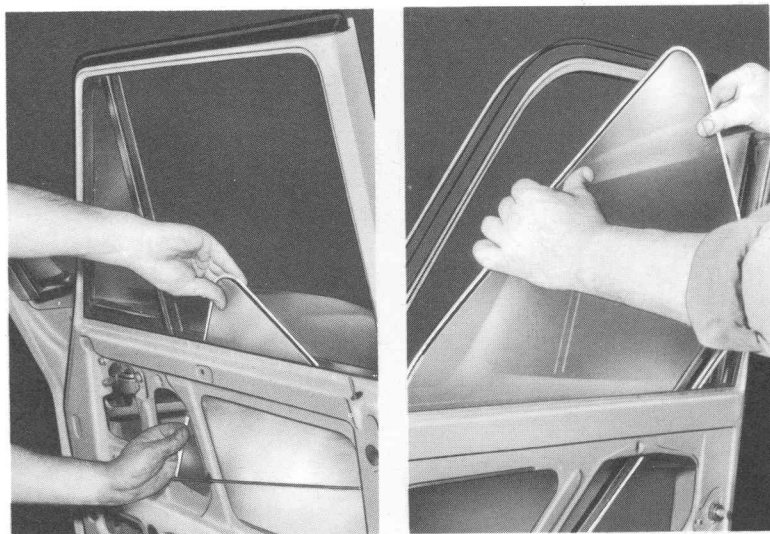

- Tilt the glass by 90 degrees so that the bottom edge is brought parallel with the rear post of door frame (front door glass) and with the front of door frame (rear door glass).

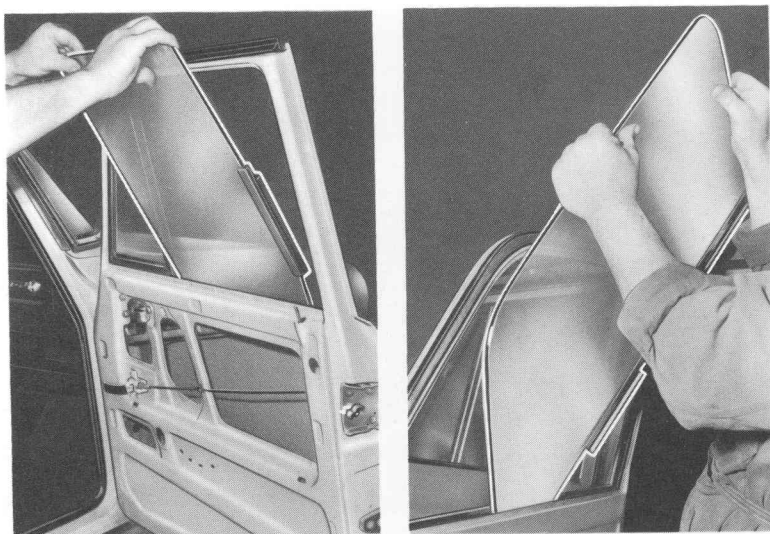

- Tip the glass inward and lift it out carefully.

INSTALLATION

Proceed in reverse order of removal.

FRONT VENT WINDOWS

1750 Saloon is shown for example purpose.

REMOVAL

- Remove the door trim panel and detach the plastic sheet (see page 37).

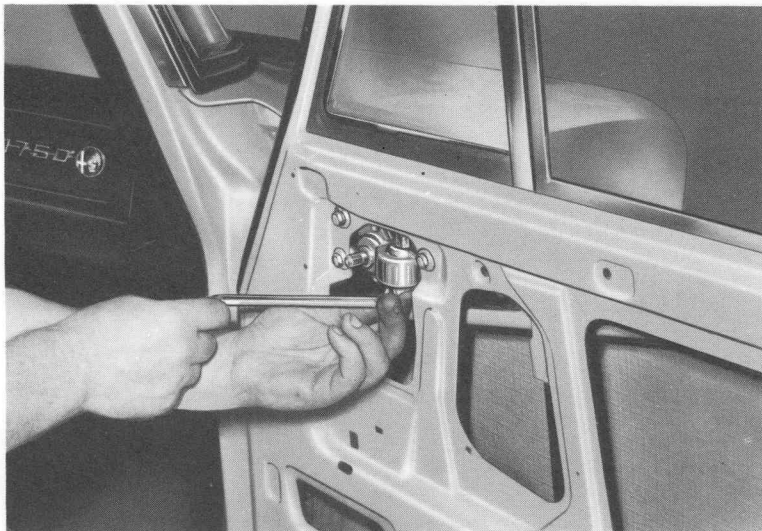

- With a Phillips screwdriver remove the vent window securing screw.



- With a socket wrench remove the screws securing the vent window control mechanism.



- Remove the vent window control mechanism.

REMOVAL AND INSTALLATION

FRONT VENT WINDOWS



- Separate the weatherstrip from the frame and remove the screws securing the vent window pivot bracket.

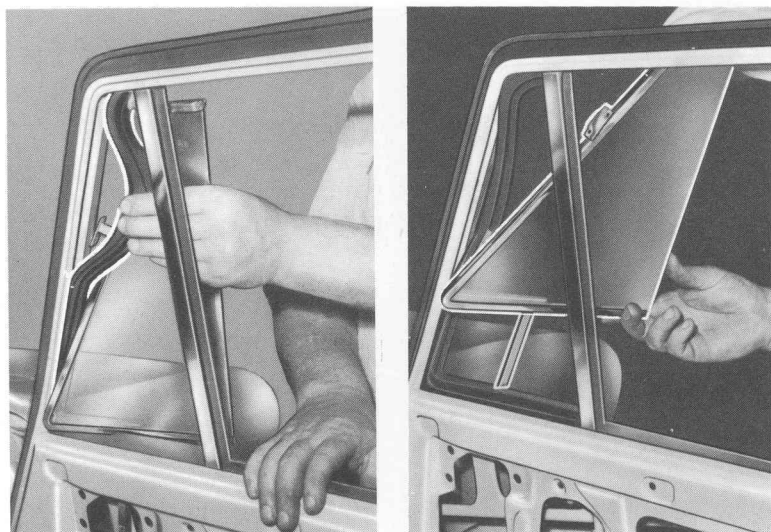

- Tilt the vent window so that it can be lifted out of the opening.

INSTALLATION

Reverse the removal procedure.

NOTE – On Giulia 1300-1300TI-1600S Saloon models and GTA Coupe models, in the event the vent window catch peg has come off the glass, stick it again in place as follows:

- Thoroughly clean the affected surfaces with alcohol.
- Apply a thin coat of cement to both surfaces.
- Secure the peg to the glass with a clamp and keep it so clamped until the cement is dried (about 24 hours at room temperature).

DOOR WEATHERSTRIPS

The same procedure applies to all Saloon models.
Giulia Saloon is shown for example purpose.

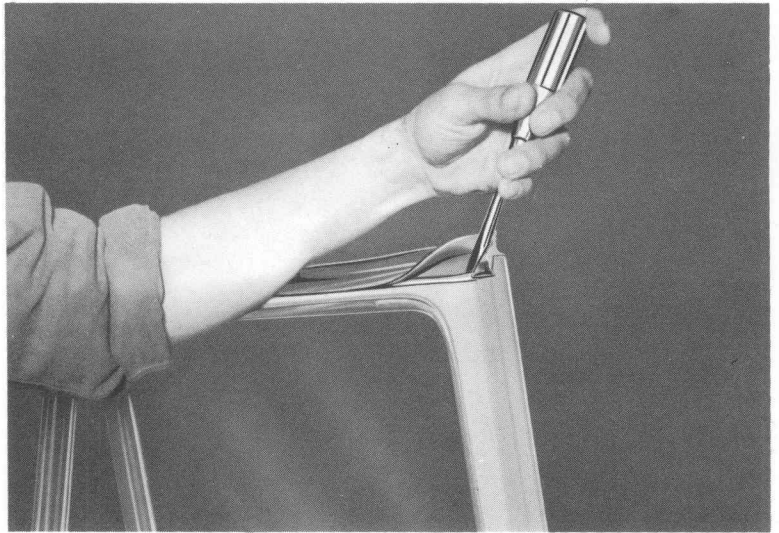

REMOVAL

- At the door top, lift off the edge of metal strip retaining the weatherstrip.

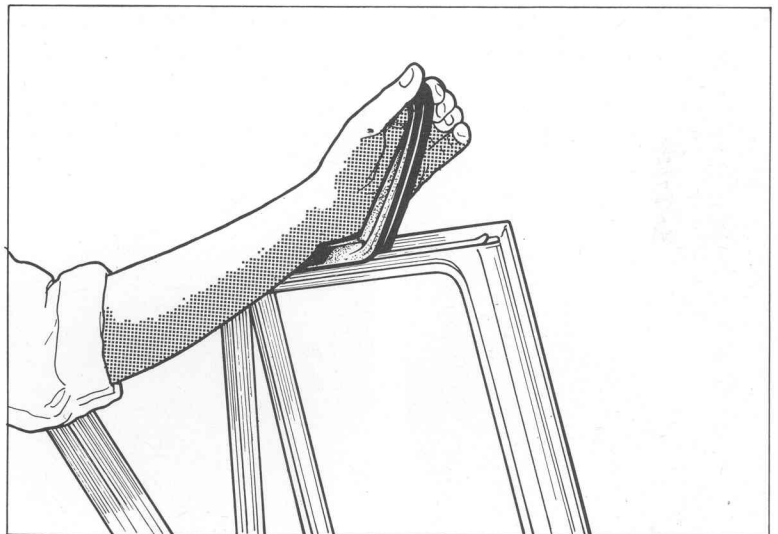

- Pull the weatherstrip away from the metal strip.

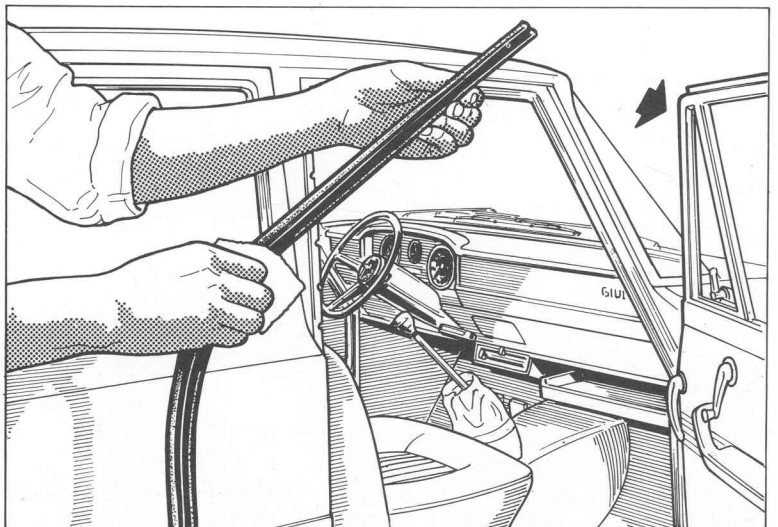

INSTALLATION

- Cover the weatherstrip with petroleum jelly or similar.

REMOVAL AND INSTALLATION

DOOR WEATHERSTRIPS

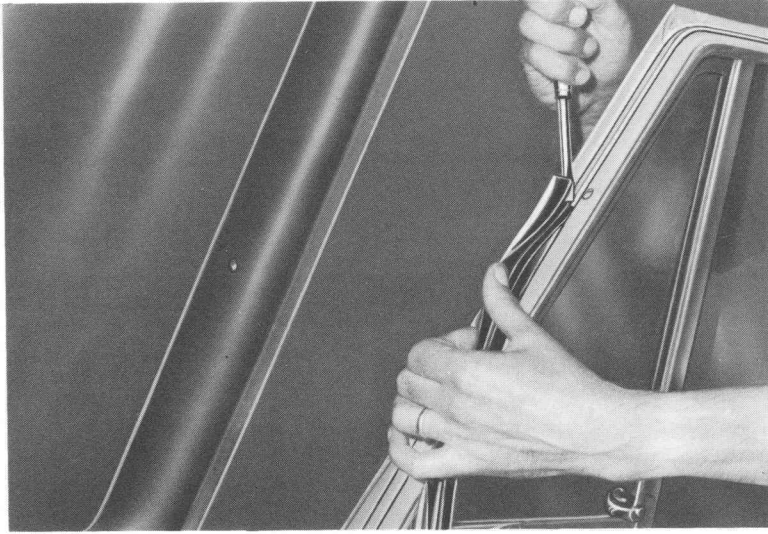

- Place the weatherstrip onto the metal strip:
 - on front doors start from the front post;
 - on rear doors start from the rear post.

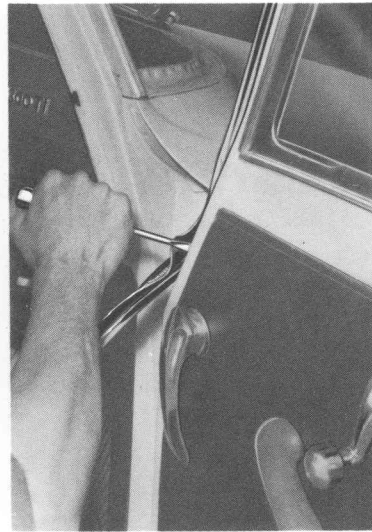
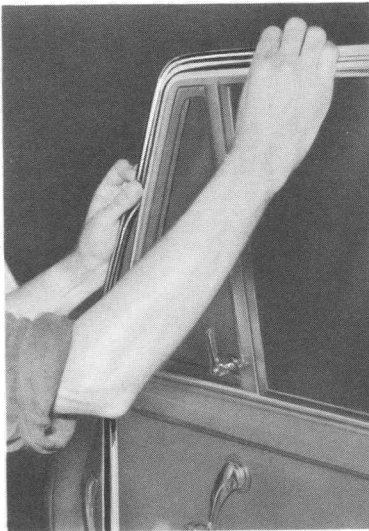

- Slide the weatherstrip along the metal strip.
- Use a screwdriver or a similar tool as an aid.
- Bend down the edge of weatherstrip retainer previously lifted.

FRONT SEATS

1750 Saloon is shown for example purpose.

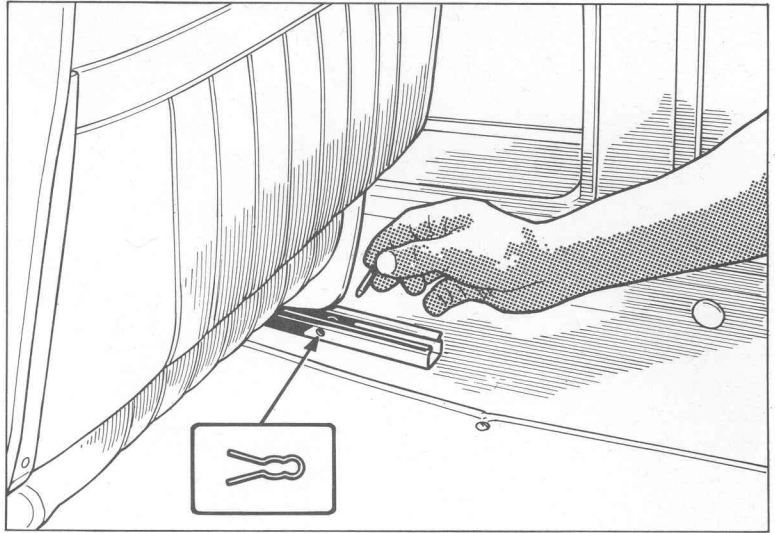

REMOVAL

- Remove the clip and withdraw the limit stop from the slide.

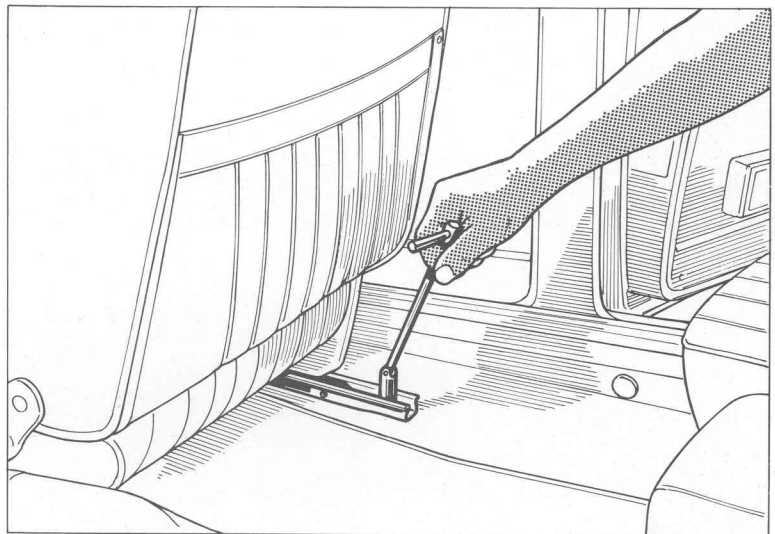

- Remove the front and rear slide attaching screws.

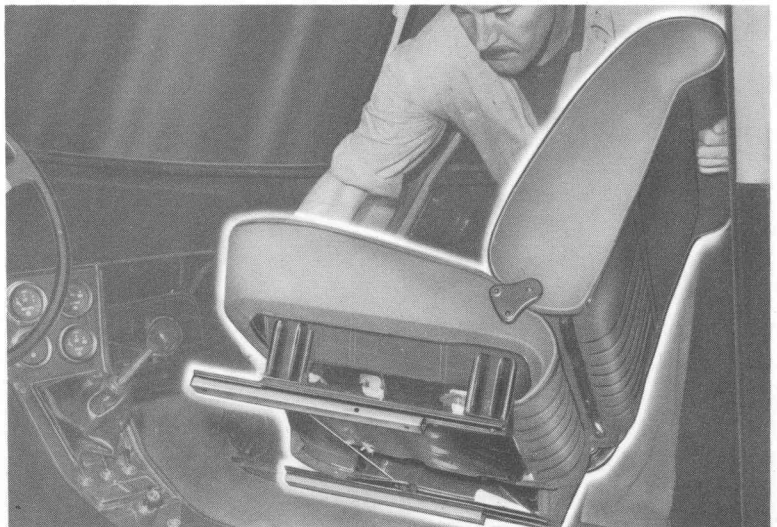

- Remove the seat.

INSTALLATION

Reverse the order of removal.

FACIA BOARD

1750 Saloon is shown for example purpose.



REMOVAL

CAUTION – Before commencing removal, disconnect battery terminals.

- Remove the trim panels from wind-screen pillars.



- Remove the air outlets by lifting them off so as to separate them from the rubber ducts underneath.

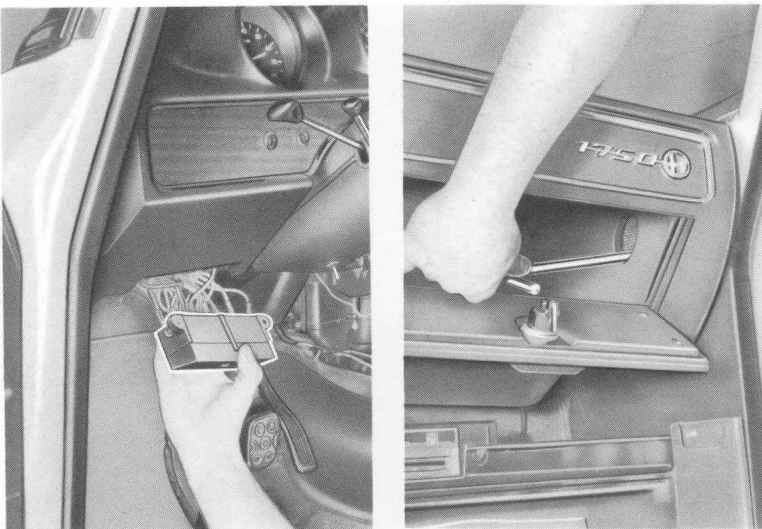

- Unscrew the attaching nuts:
 - at the right side gain access from the glove box;
 - at the left side gain access by detaching the fusebox.

FACIA BOARD

- Remove the centre attaching screws.
- From the underside, unscrew the two wingnuts securing the panel to the console.

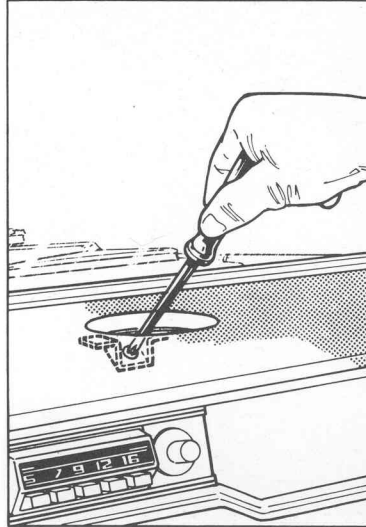

- Unscrew the ringnut securing the tripometer reset.

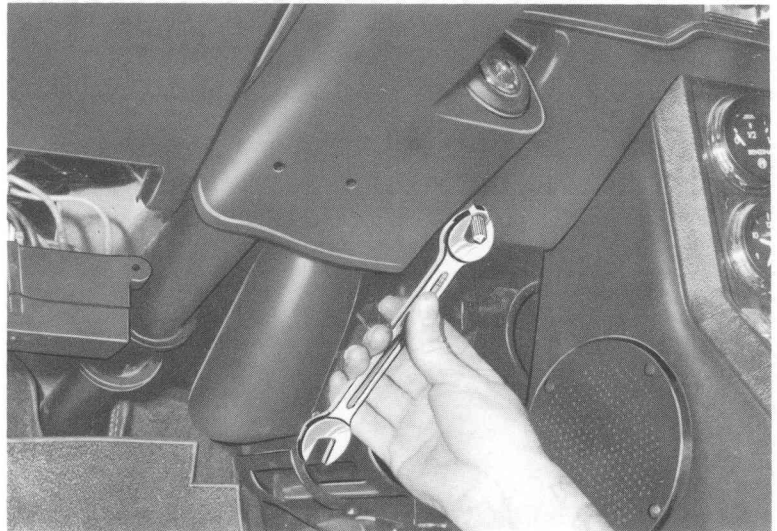

- Take out the instruments, disconnect wires and lamp holders.

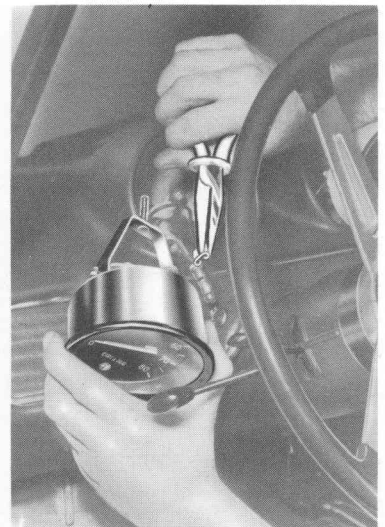
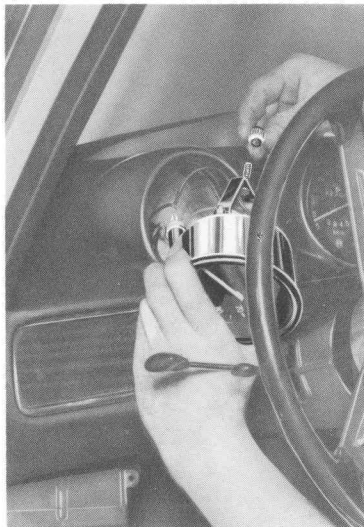

REMOVAL AND INSTALLATION

FACIA BOARD

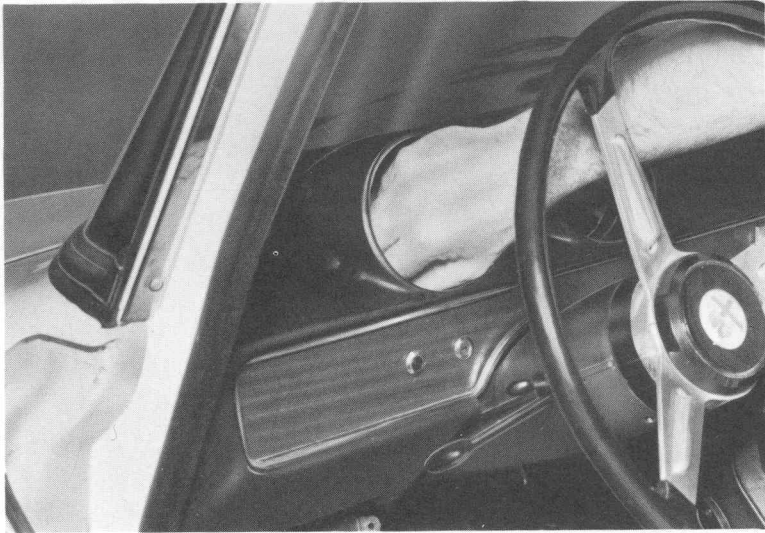

- From the inside, disconnect wires of warning lights and direction indicators.

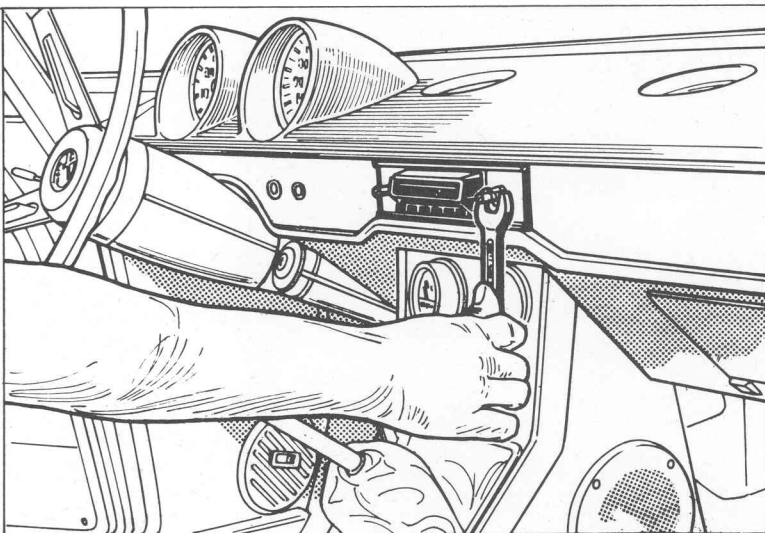

- Free the radio (if so equipped) from the fascia board.



- Remove board.

FACIA BOARD

- Disconnect wires and remove the radio.

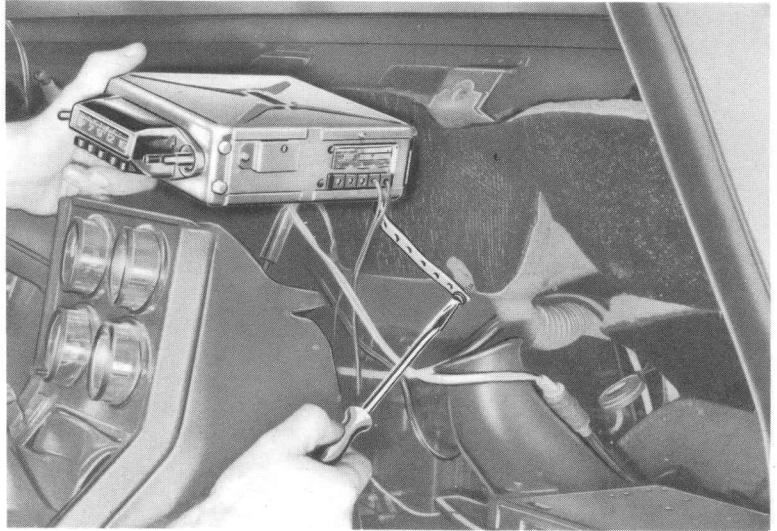

- In order to perform the subsequent operations easily, it is advisable to tie the wires together in a bundle.

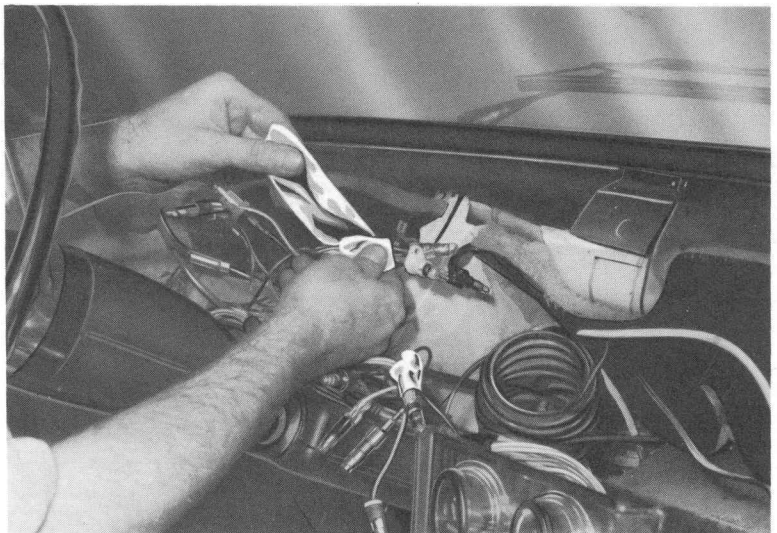

INSTALLATION

Reverse the removal procedure.

CONSOLE

1750 Saloon is shown for example purpose.

NOTE – When removing the console, it is unnecessary to remove the facia board too; only carry out the following:

- unscrew the wingnuts securing console to facia board (see fig. 2, page 51).
- slacken the facia board attaching nuts at the sides (see fig. 3 and 4, page 50).
- raise the facia board just enough to allow to remove the console.

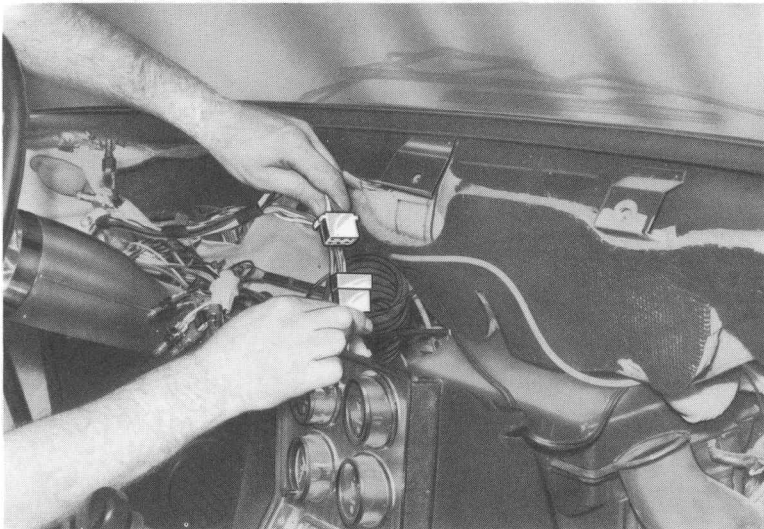

REMOVAL

- Remove front seats (see page 49).
- Disconnect the wiring junction gaining access from behind the console (unless the facia board has not been previously removed).

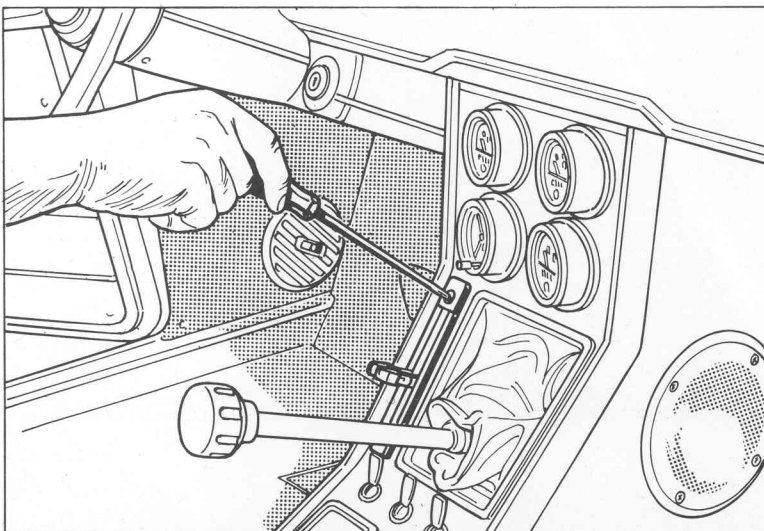

- Remove the escutcheon from heater control panel.

CONSOLE

- Remove knobs from heater control levers.

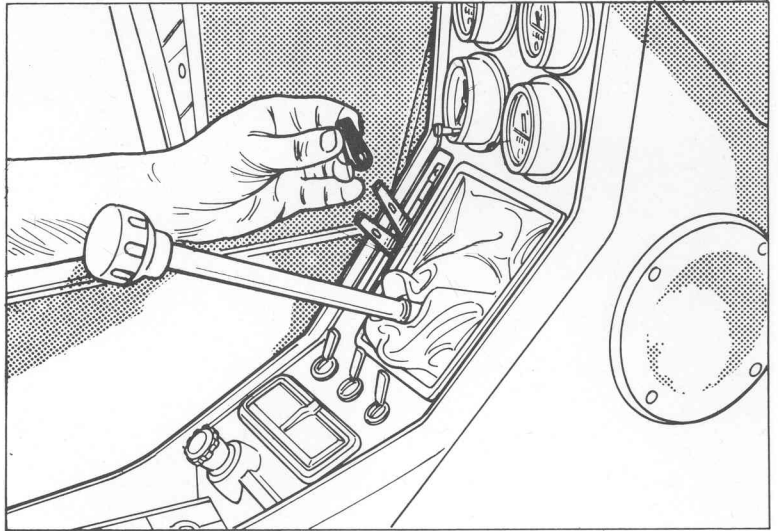

- Remove gear lever knob.

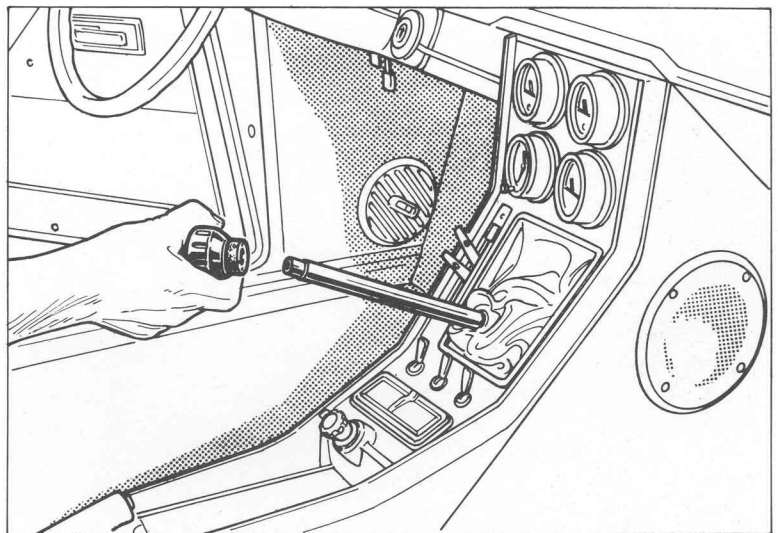

- Remove carpets and slacken off console side attaching screws.

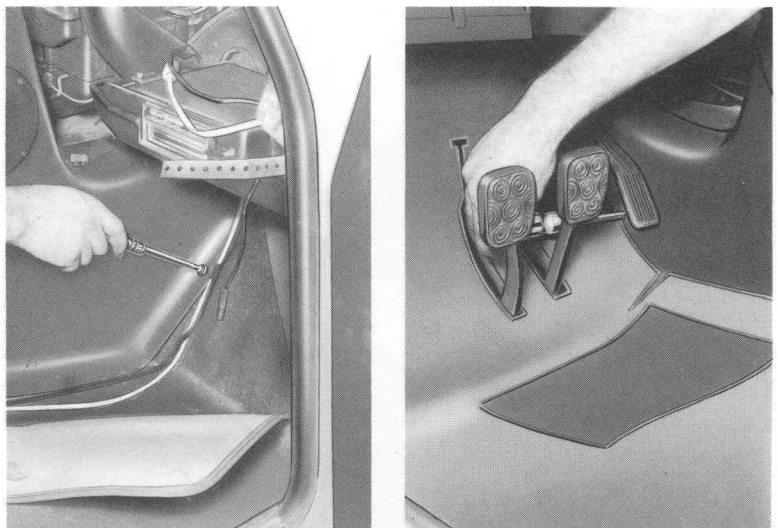

REMOVAL AND INSTALLATION

CONSOLE

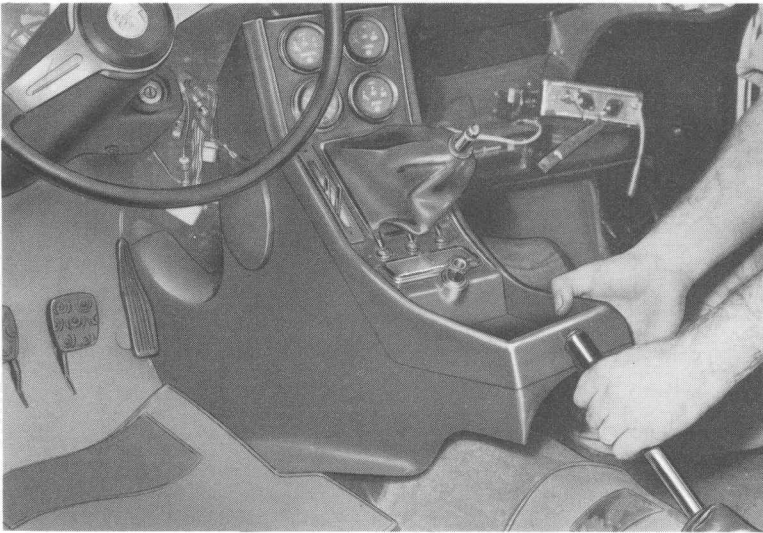

- Pull up handbrake lever and raise the console as shown.

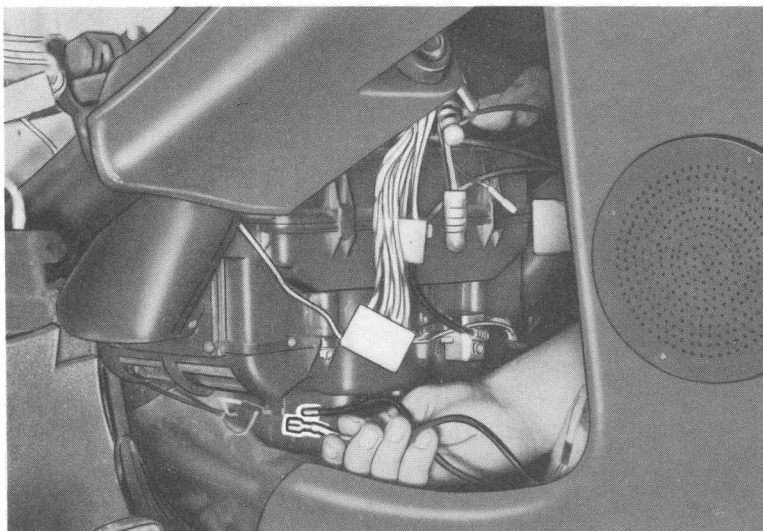

- Disconnect heater junction to allow the console to be removed.

INSTALLATION

Reverse the removal procedure.

ROOF TRIMMING

The same procedure applies to all Saloon and Coupe models.
Giulia and 1750 Saloon are shown for example purpose.

REMOVAL

- Remove trim panels from windscreen pillars.

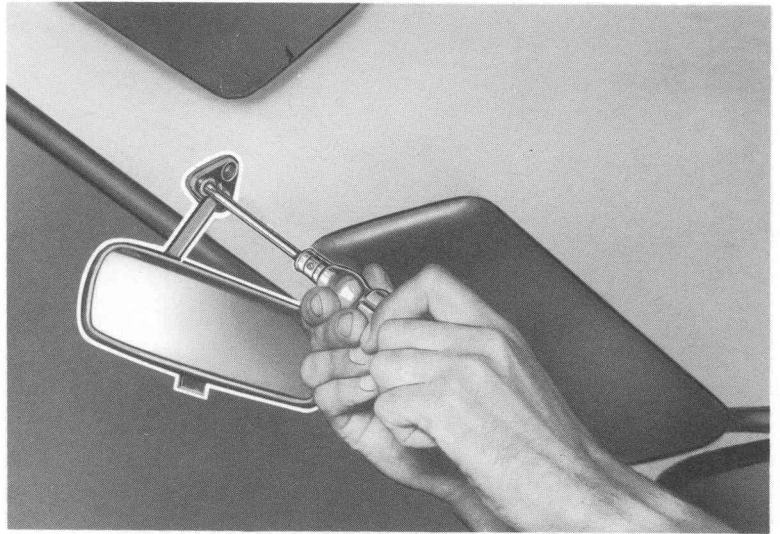

- Remove mirror and sun visors.



ROOF TRIMMING

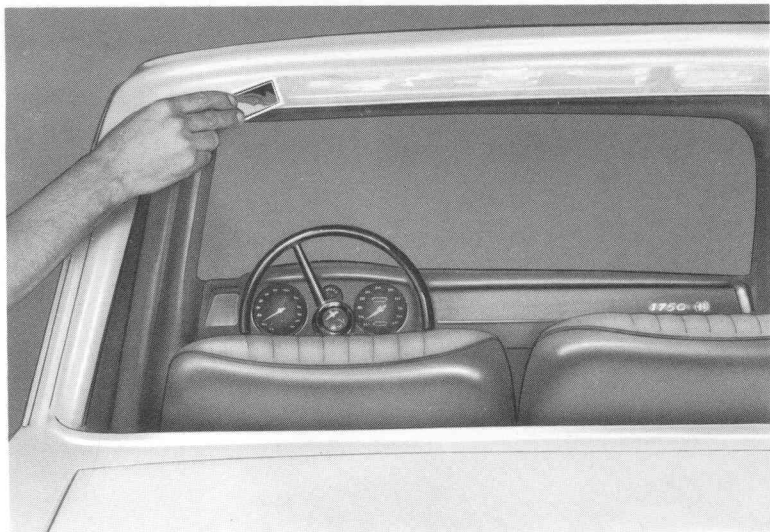

- Remove windscreen and rear window. (see page 31).
- Carefully remove the sealing compound with a suitable spatula (wooden or plastic) in order not to damage the paint layers; then, clean thoroughly with a suitable solvent.

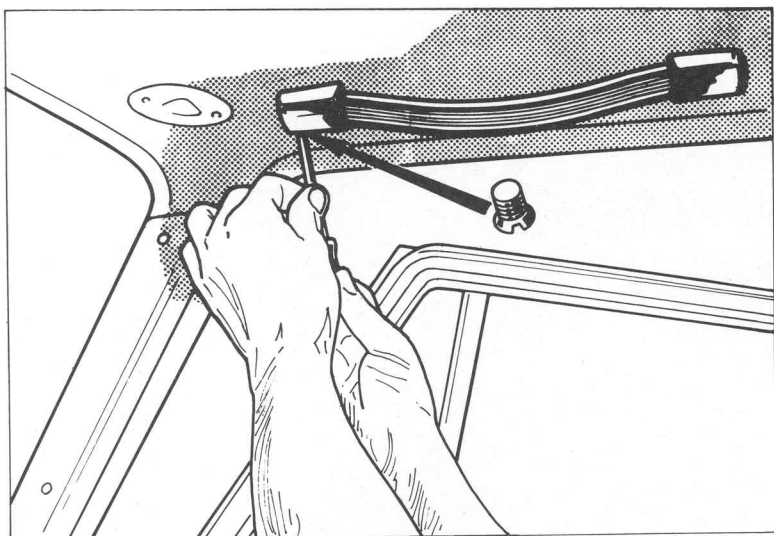

- Loosen the setscrews and remove the finishers over the ends of grab handle at passenger's side, then remove the grab handle.

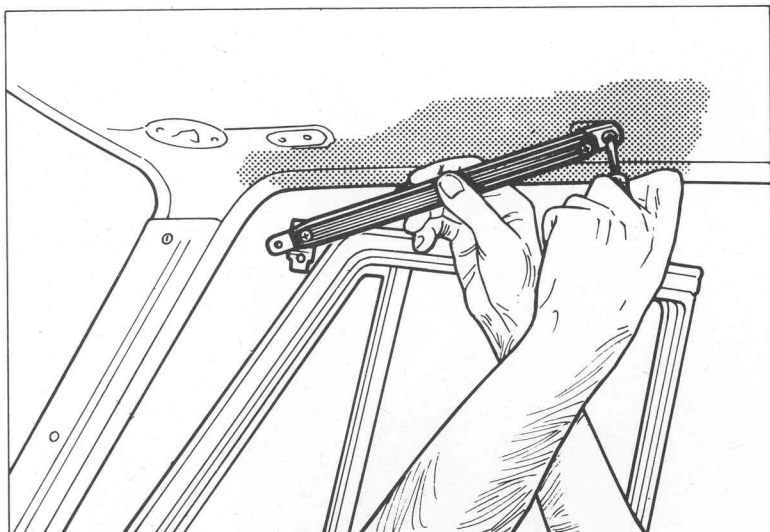

ROOF TRIMMING

- Remove clothes-pegs.

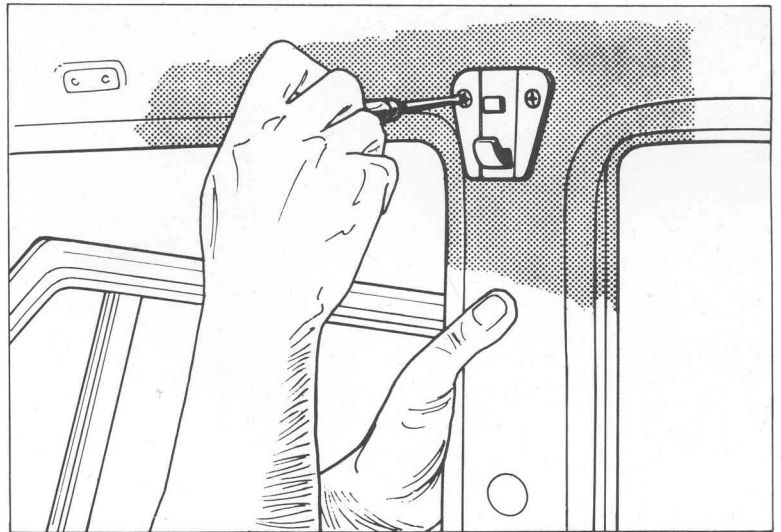

- Remove the rear handle and light units.



- Remove the rear seat cushion.

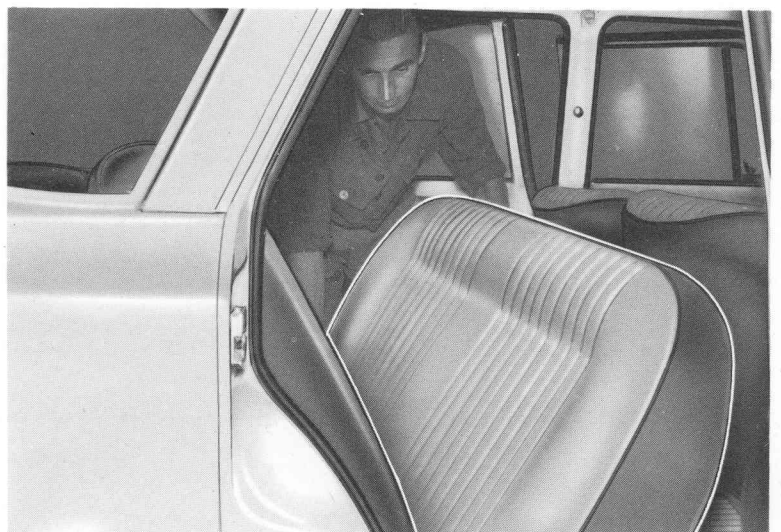

ROOF TRIMMING



- Remove the attaching screws at the bottom and take away the squab.

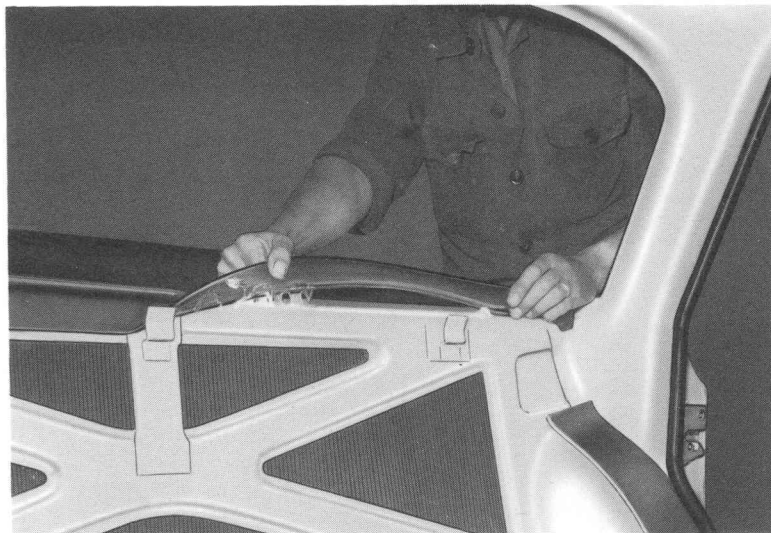

- Detach the front edge of parcel shelf trim.

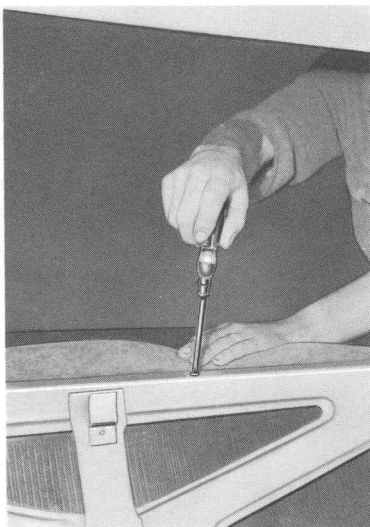

- Slacken off the attaching screws and remove rear parcel shelf.

ROOF TRIMMING

- Disengage door opening weatherstrips from the clips.

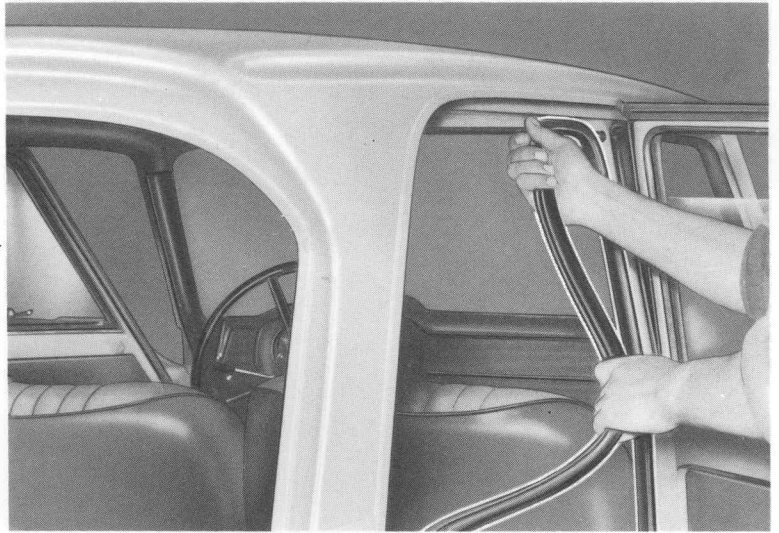

- Remove the clips along the edge affecting roof trim.

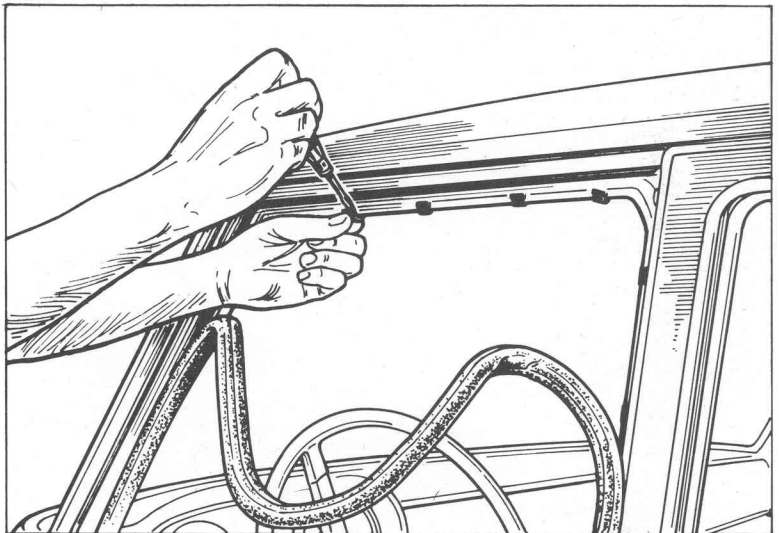

- Detach wheelarch edge trim.

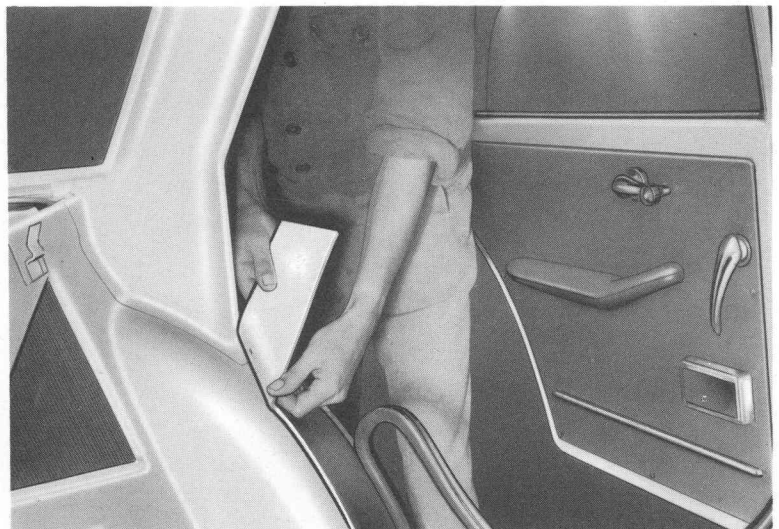

ROOF TRIMMING

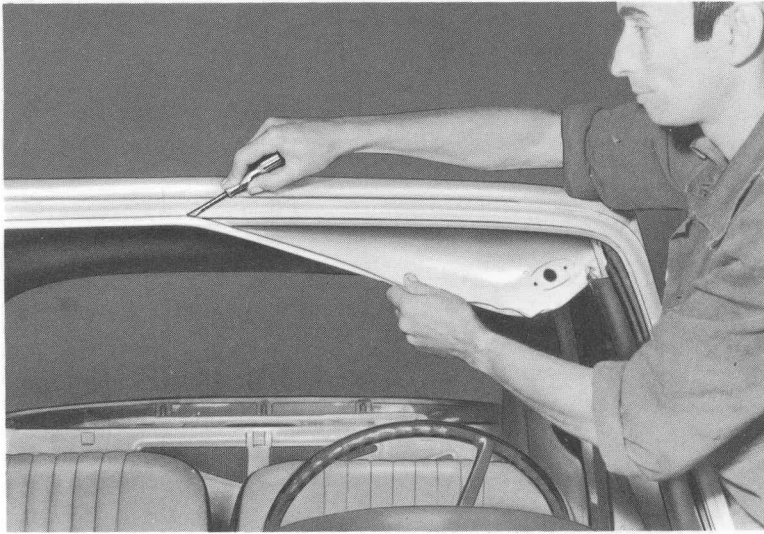

- Detach roof trim starting from the front header and proceeding toward the rear window.

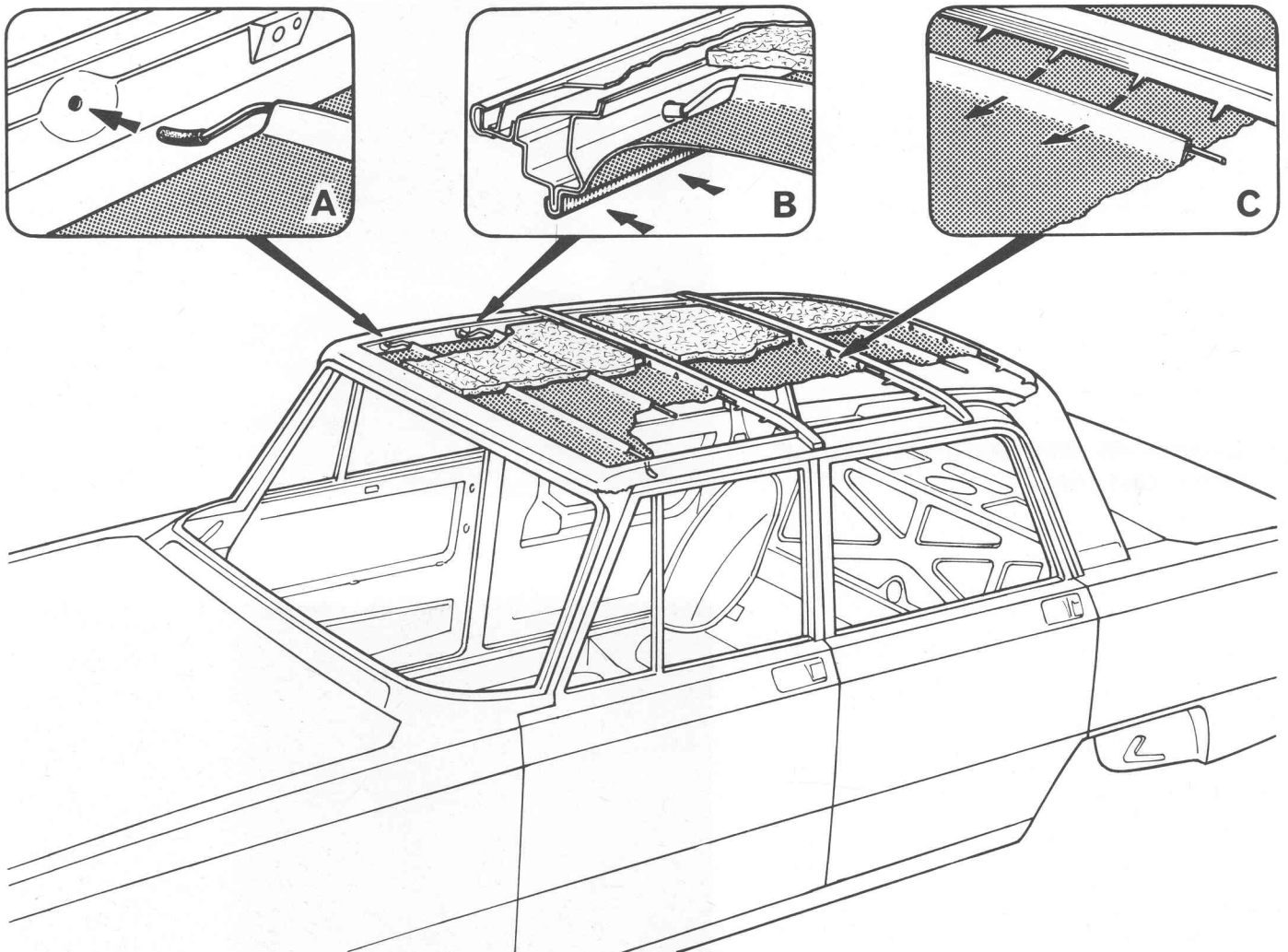

- A – Mounting holes for roof trim stiffening bows.
- B – Areas in which roof trim is stuck to roof panel.
- C – Hooks for fastening trim bows to roof ribs.

ROOF TRIMMING

- Take front stiffening bow out of its mounting holes (see detail view A on page 62); then remove next bow, too.

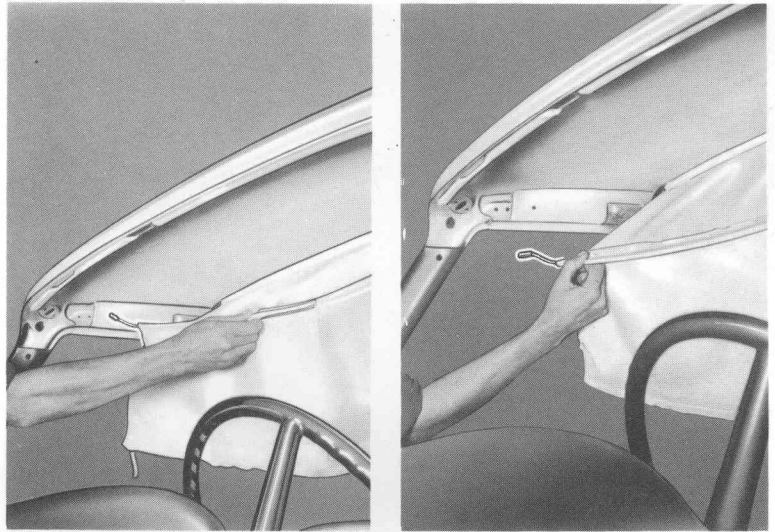

- Use special tool P.N. A.9.0103 to straighten the bow fastening hooks on first roof rib so that the bow can be removed (see detail view C on page 62); then, repeat the procedure for the second rib.

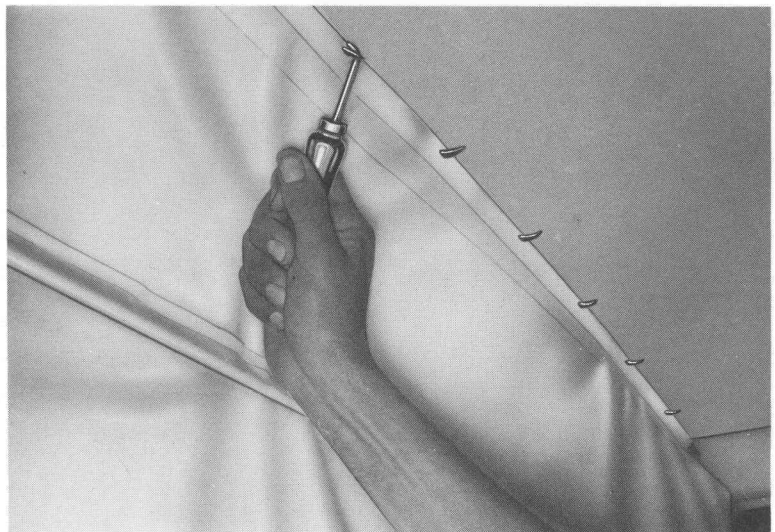

ROOF TRIMMING

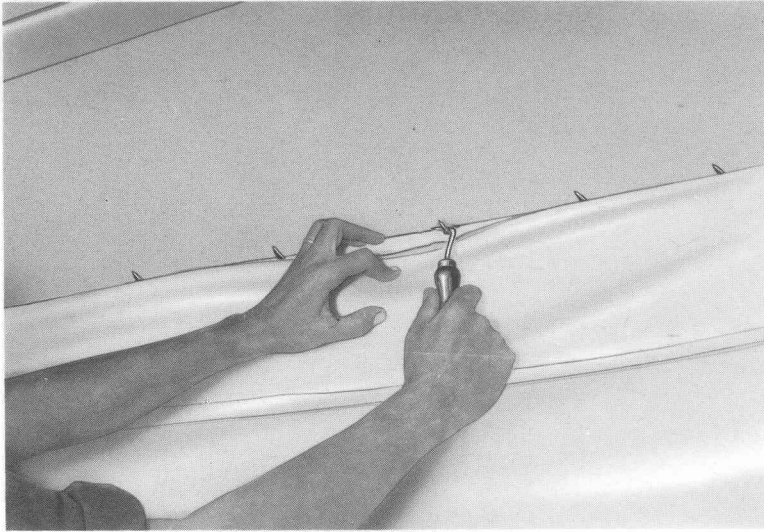

- Take out of mounting holes the rim bow located just after the second rib.
- Straighten hooks and remove the rear bow from the rib.

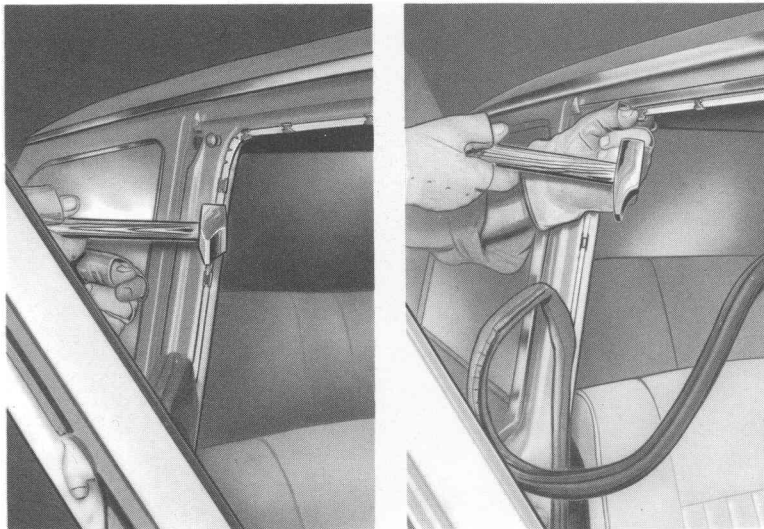

INSTALLATION

Reverse removal procedure.

WARNING – To ensure proper weatherstrip fitting, carefully reset the clips, replacing those damaged or missing with new ones.

INSULATION PADDING

Soundproofing is obtained by lining the body as shown below with insulation pads of the following types:

— “Sound deadening” panels

Consisting of bituminized material applied at 120 degrees centigrade to the sheet metal so as to ensure perfect adhesion.

— “Sound absorbing” panels

Made up with layers of natural and artificial fibers, they are bonded with suitable resins and have high porosity and light weight characteristics; together with bituminized panels they are glued to the body inside with neoprene cements of standard type commonly available on the market.

On repairing, renew all soundproofing pads not in good conditions so that the insulation properties of car are not impaired.

The illustration below shows how insulation pads are applied to the 1750 Saloon.

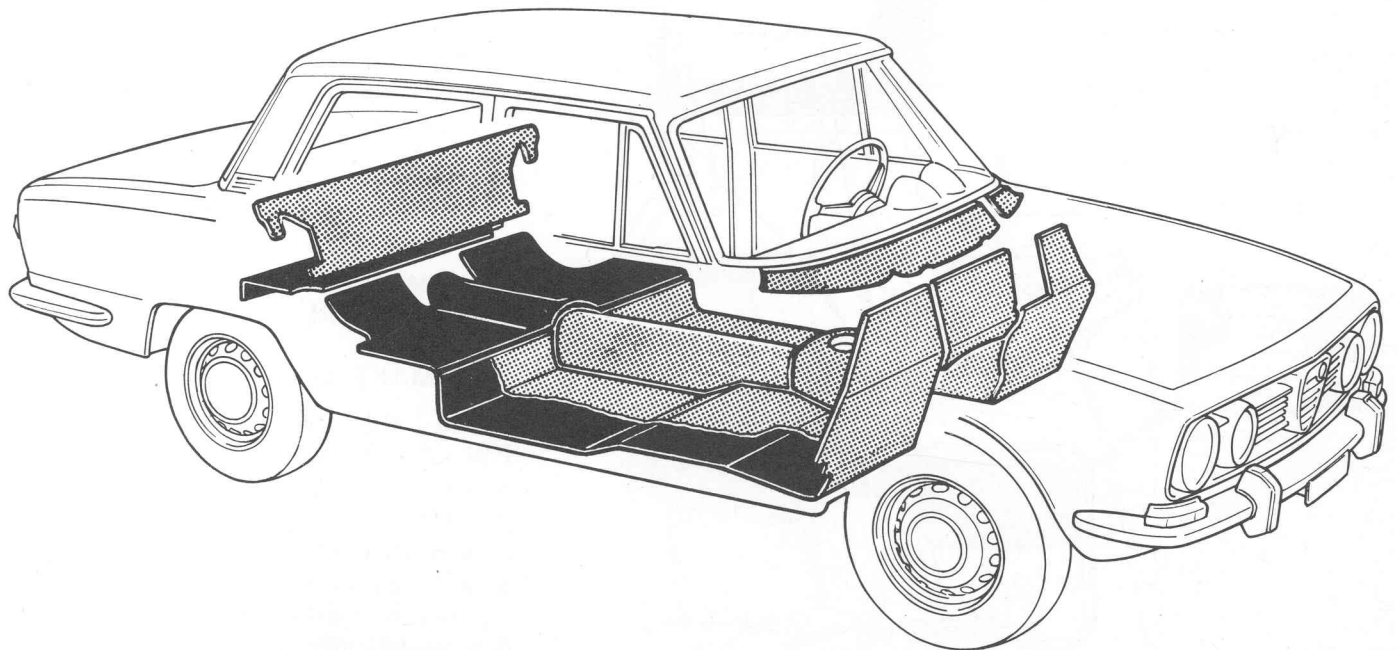

 Sound absorbing panels

 Sound deadening panels

DOOR LOCKS

The same procedure applies to all Saloon and Coupe models.
1750 Saloon is shown for example purpose.

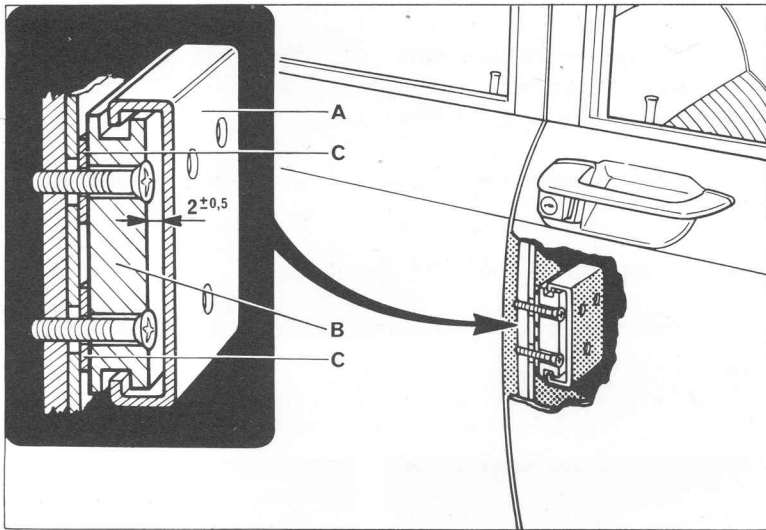

- A – Dovetail
- B – Striker
- C – Spacer

To remedy possible noise from door locks, it is necessary:

- To check that there is a clearance of 1.5 mm minimum and 2.5 mm maximum between the dovetail and striker by inserting a plastigage or similar between them.
If clearance is not as specified, slacken the striker screws and add or remove shims (0.5,1,2 mm), taking care to keep the striker parallel with the dovetail.

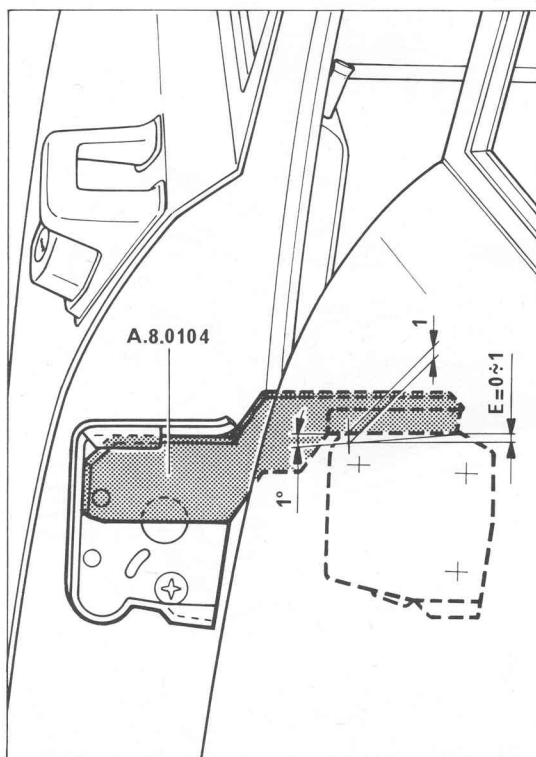

- To check for proper alignment of striker, proceed as follows:

KEIPER MAKE LOCKS

- Place the template, special tool P.N. A.8.0104, into the dovetail and make sure it fits properly against the dovetail top edge. The proper adjustment of striker is when engagement E with dovetail falls within 0 and a maximum interference fit of 1 mm and downward tilt does not exceed 1 degree. Such a condition is fulfilled when 1 mm gap exists between the template and the leading edge of striker top.

DOOR LOCKS

SAFE MAKE LOCKS

- Place the template, special tool P.N. A.8.0102, into the dovetail. The striker engagement E with dovetail should fall within O and a maximum interference fit of 1 mm; and should have a tilt of no more than 1 degree corresponding to a 0.7 mm gap.

NOTE: – on models with guide block, the lock striker should fit perfectly the dovetail or with an interference E from 0.5 to 1.5 mm maximum.

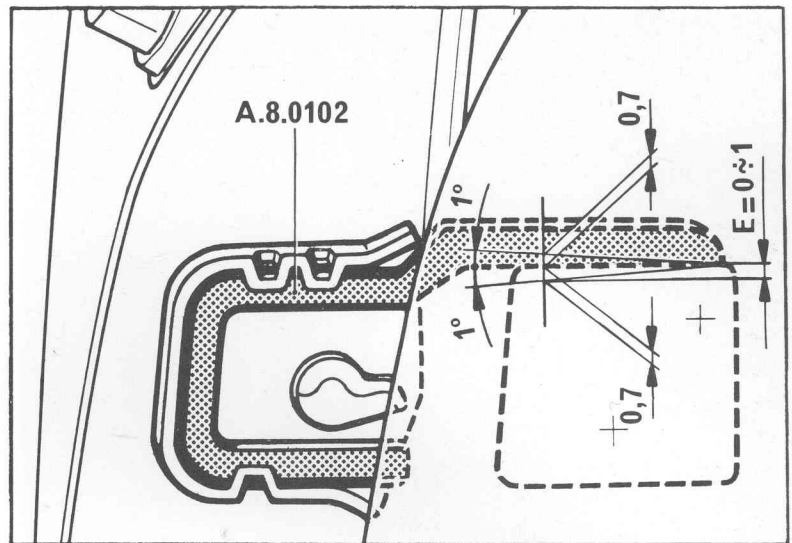

- Check the location of the catch with the aid of the template, special tool P.N. A.8.0103 and, in the event the catch has an interference fit, make the required adjustment as follows:

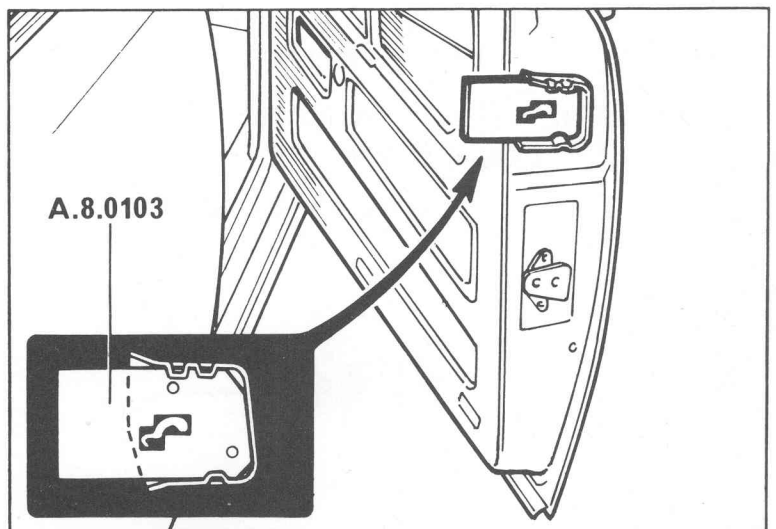

- Slacken the screws securing the bracket of inside door handle.
- Adjust the position of the bracket until no more interference exists in the fit as mentioned above.

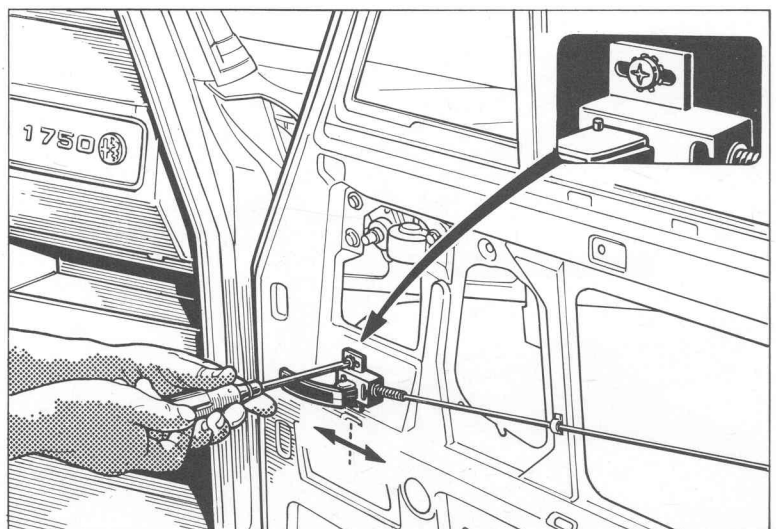

CHECKING AND ADJUSTING

DOOR LOCKS

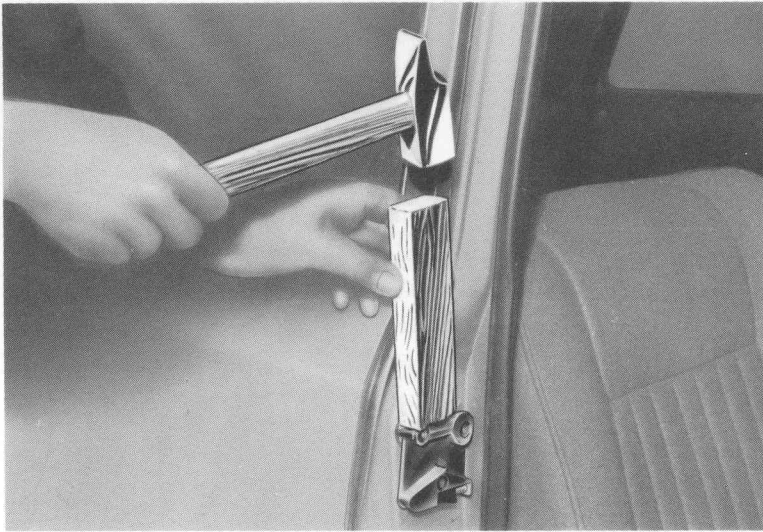

- For adjusting the position of the striker use a wooden block as shown.

- On completion of the above outlined procedure, lock striker screws to $130 \text{ Kgcm} \pm 5\%$ with a torque wrench whose rating should be 80 to 320 Kgcm.

CAUTION – If the locks are to be securely fixed into alignment, their attaching screws must be tightened with a torque wrench, never with a screwdriver.

ENGINE HOOD

1750 Saloon is shown for example purpose.



Should any interference exist between the leading edge of engine hood and the front panel top, proceed as follows:

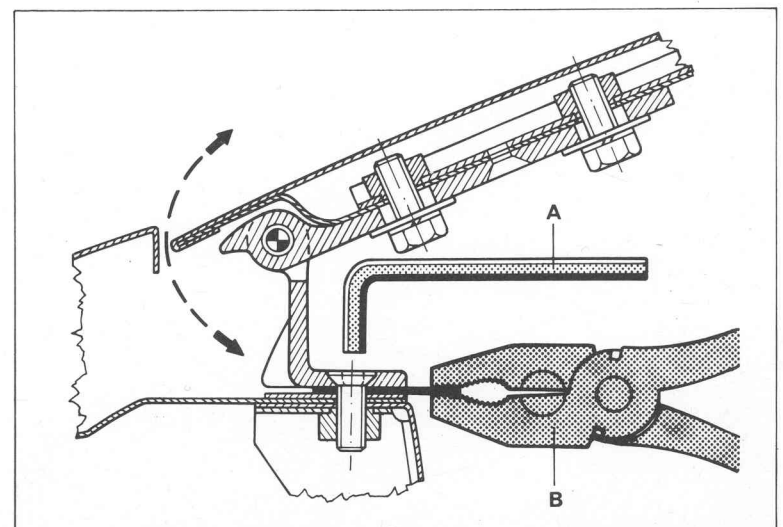
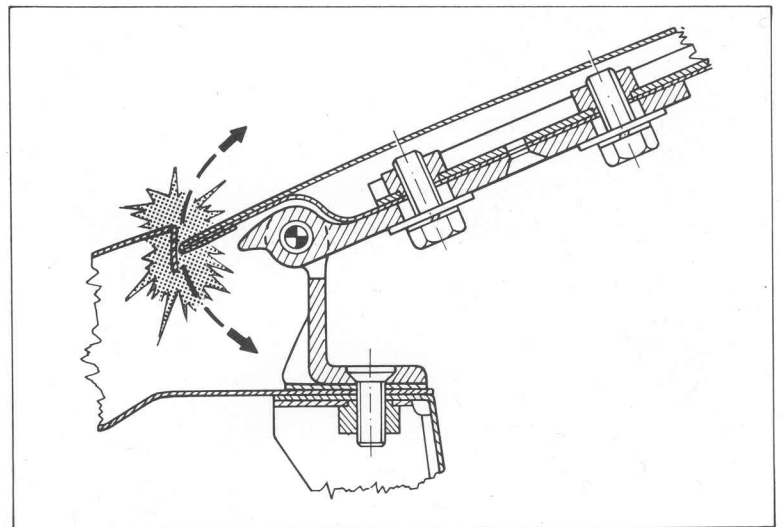

- With an Allen wrench A, loosen the screws attaching hinge to body (at the side affected by interference troubles).
- With pliers B, insert shims between hinge and body until hood rotates freely, then retighten the hinge attaching screws.

ENGINE HOOD

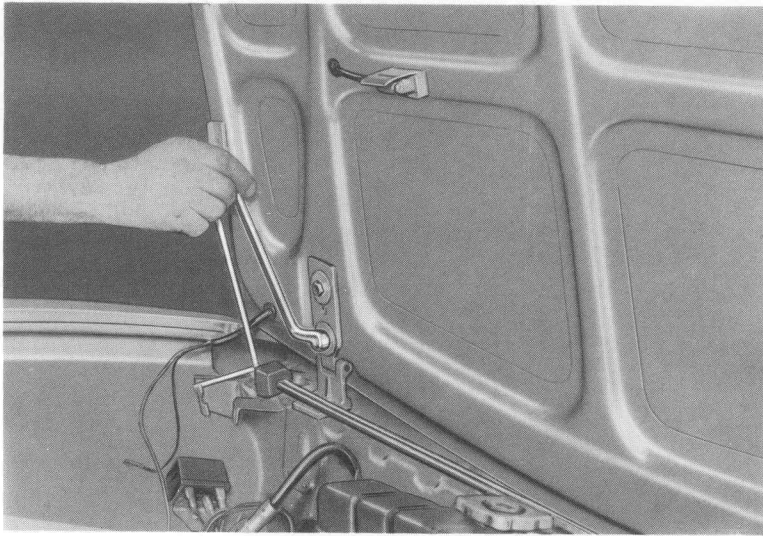

In the event engine hood is misaligned laterally or longitudinally:

- Slacken the two screws attaching hinge to hood panel.

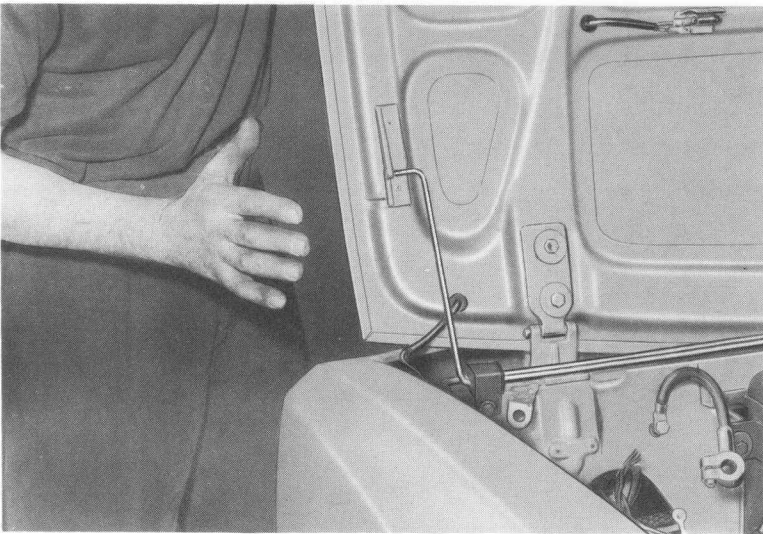

- Tapping by hand, move the hood as required.
- Check for proper alignment then retighten the screws.

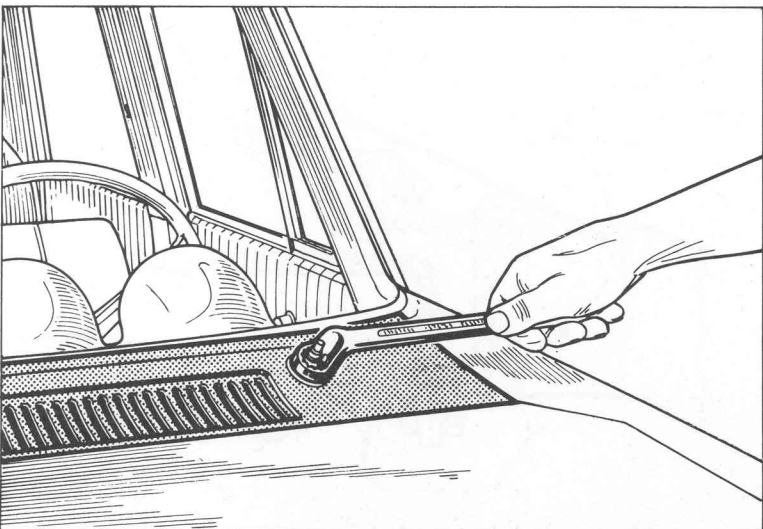

If a misalignment of the hood rear edge is experienced as a consequence of the above operations:

- Remove windscreen wiper arms.
- Slacken one or both the ringnuts securing the scuttle top panel.

ENGINE HOOD

- Position the scuttle top as required and, holding the panel firmly in place, retighten the ringnuts.

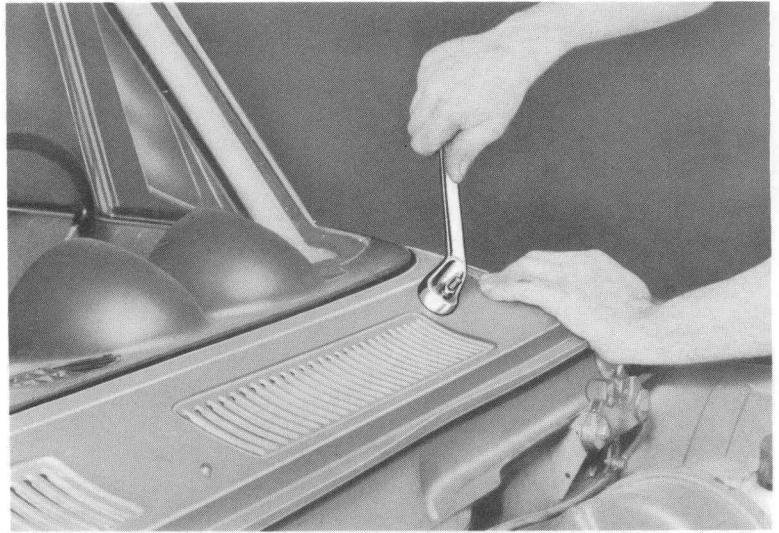

To adjust the hood locks:

- Slacken lock attaching screws.

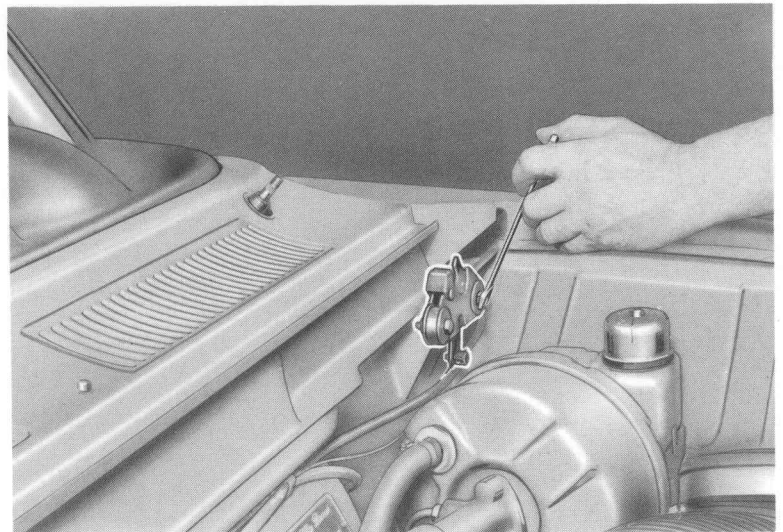

- Adjust the position of locks in such a way that both locks close at the same time when the hood is in proper alignment with the adjoining parts.
- Retighten lock attaching screws.

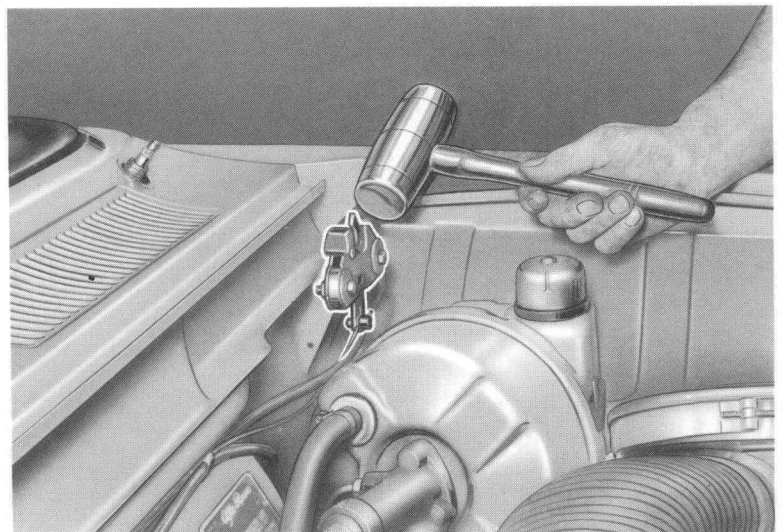

CHECKING AND ADJUSTING

LUGGAGE COMPARTMENT LID

1750 Saloon is shown for example purpose.

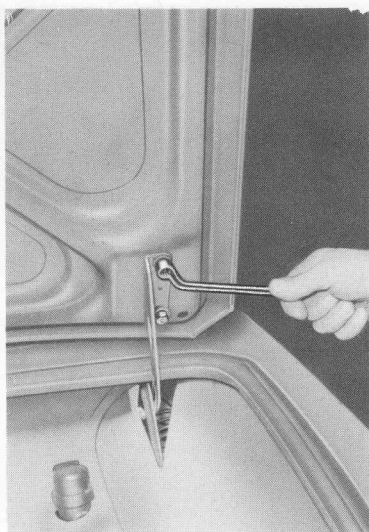
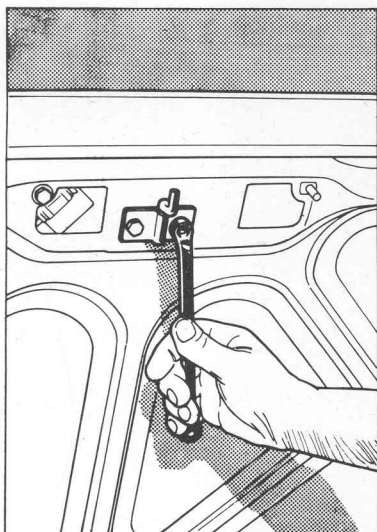

- Slacken the lock attaching screws.
- Slacken the lid hinge attaching screws.

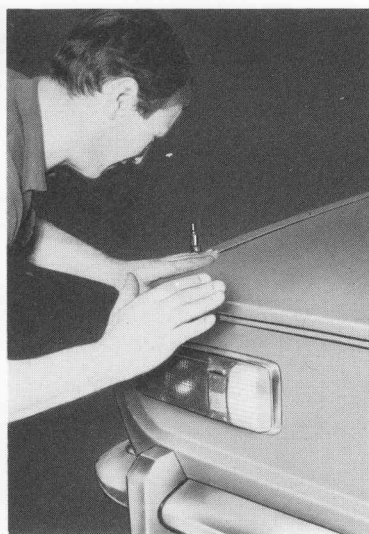

- Tapping by hand, move the lid as required.
- Check for proper alignment, then retighten the hinge screws.
- Adjust the position of the lock and tighten in place the attaching screws.

DOOR WEATHERSTRIP LEAKAGE

The same procedure applies to all Saloon and Coupe models.
1750 Saloon is shown for example purpose.

Should air or water leakage be experienced:

- Check weatherstrips for sound conditions and renew them, if necessary.
- Check for tightness by inserting a piece of paper between pillar and door. There should be some drag when trying to pull out the paper.

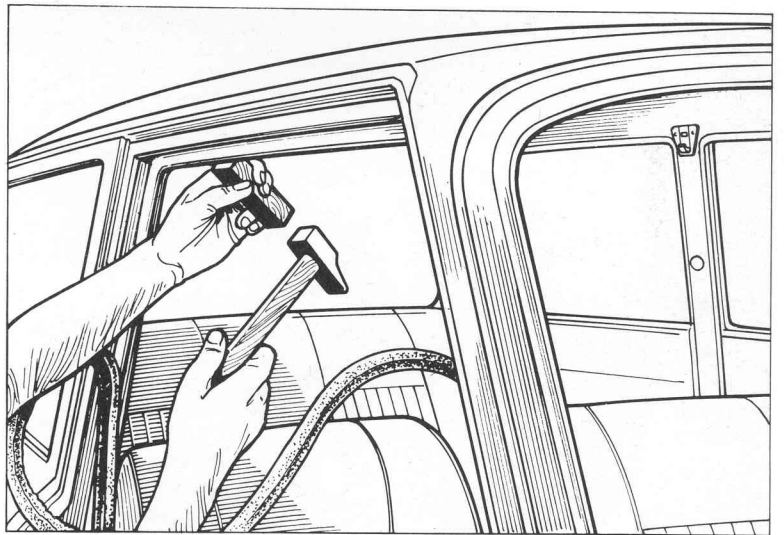
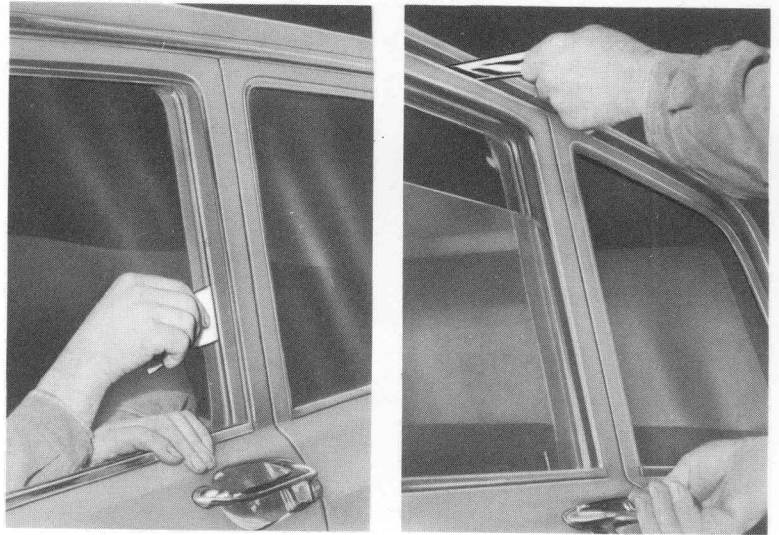

- Where needed, improve the tightness by bending outward the edge of sheet metal in the door opening. To do so, use a wooden block.

LUGGAGE COMPARTMENT SEALING

The same procedure applies to all models in this range.
1750 Saloon is shown for example purpose.

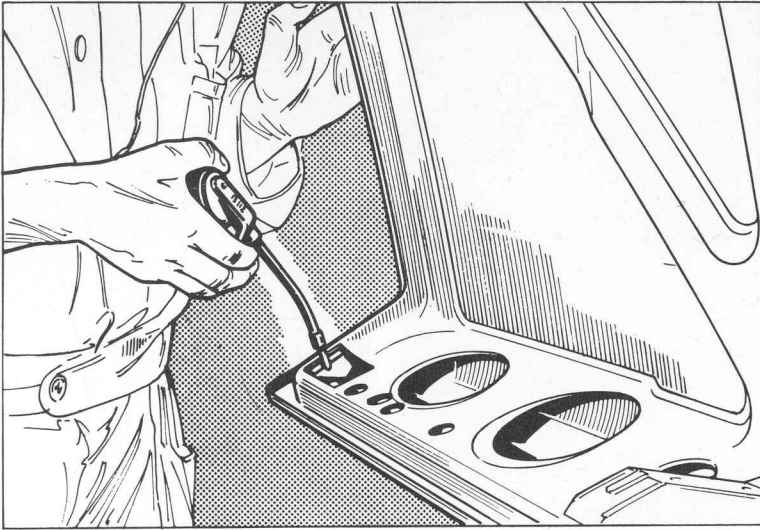

If water leakage is found, proceed as follows:

- Renew the rubber weatherstrips, if damaged.
- Check for proper sealing of lid weatherstrip by ensuring that the contacting surfaces are actually in contact.
- Check for proper sealing of screws attaching mouldings, lights, etc; if not so, apply sealing compound as required to the affected areas.

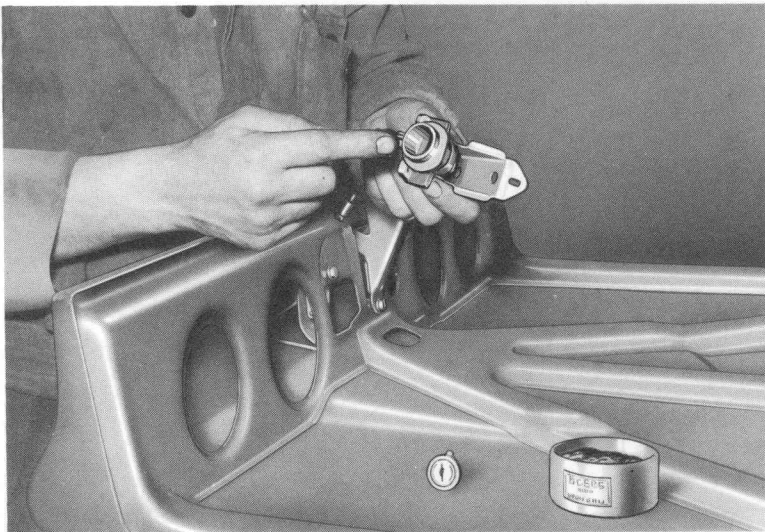

- Check the lock for proper sealing and remove it for greasing, if necessary.



- Ensure that the joining lines of sheet metal seal properly together; if necessary, apply sealing compound in the interstices; then coat the wheelarch fillets with a suitable sealer. (see page 76).

WATER TEST

To test the car properly for water seepage, use the vacuum pump, P.N. M.6.0101, and proceed as follows:

- Install the plastic panel A on the door. Raise the car window until it seals perfectly against the plastic panel.
- Close all doors and blank off any air passage (like the flow away slits "B" on 1750 Saloon) with masking tape.

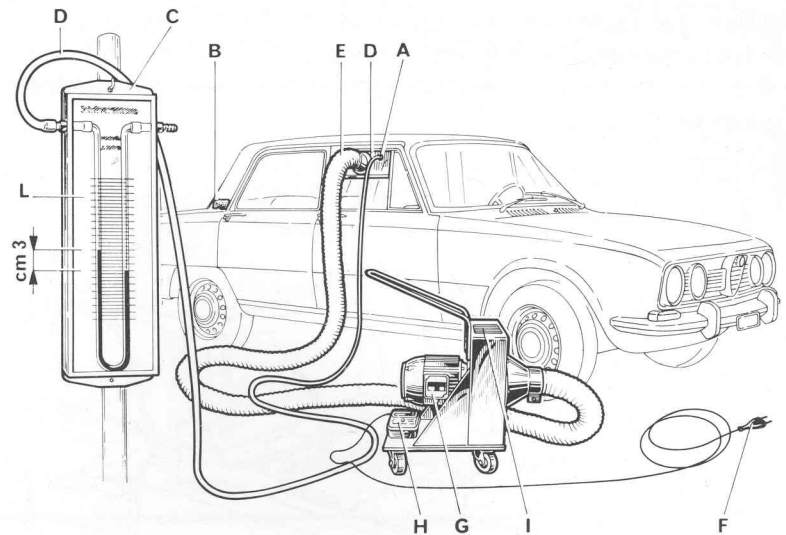

- Fill with water tinted by some drops of china ink the U-shaped tube of vacuum meter C up to about the midpoint of scale; then connect the plastic hose D to either of the adapters of meter.
- Connect the hose D also to the small adapter of plastic panel A.
- Connect the vacuum pump hose E to the large adapter of plastic panel A.
- Make sure the terminals of electric motor G are so connected as to meet the current supply voltage. Plug the cord F in a power source. Start the vacuum pump by operating the switch H.
- Adjust the vacuum control I until a reading of 30 mm is shown on the scale L of vacuum meter C.

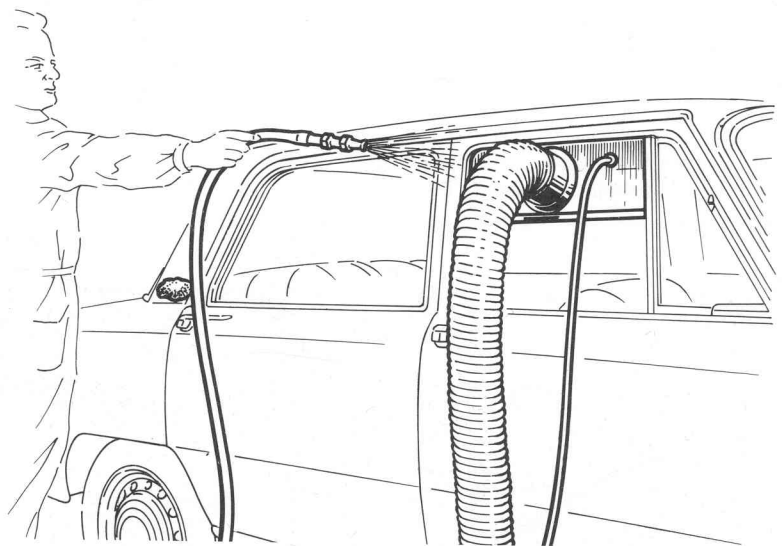

- Spray water as shown over all those areas to be tested (doors, lids, etc.).
- Switch off the pump and carefully inspect the inside of car for water seepage.

NOTE — Do not vacuum test the car under "rain" in a tunnel as in this way there will be water seepage even in areas in which, under usual operating conditions, no water can pass through.

SEALING

After the repair or the replacement of sheet metal panels, ensure a proper waterproofing by applying suitable sealing compounds in the areas shown below.

The specifications of such sealing compounds, subdivided in type A-B-C for classification purpose, are given on page 83.

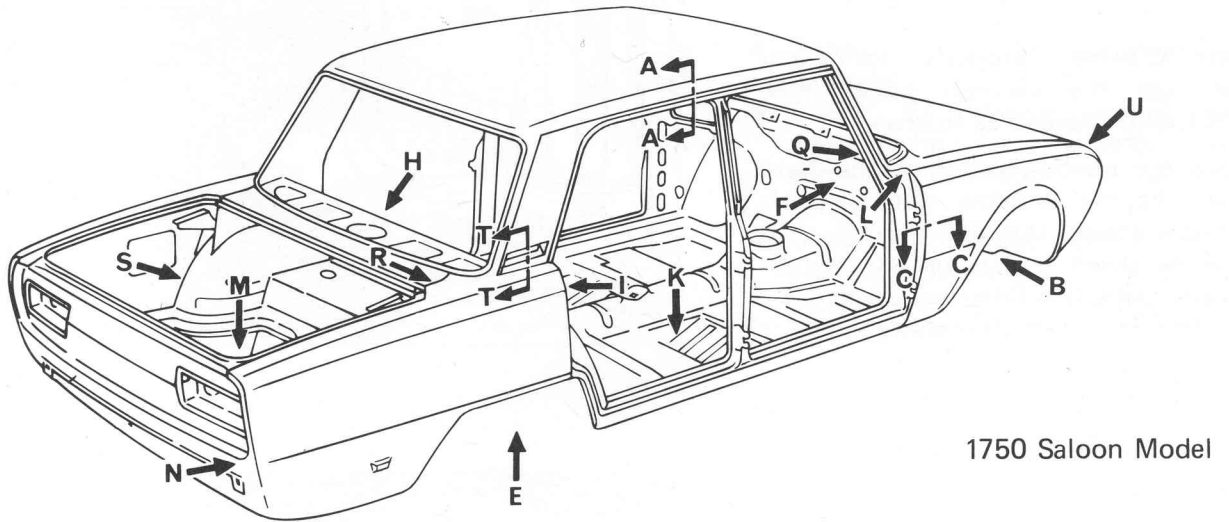

1750 Saloon Model

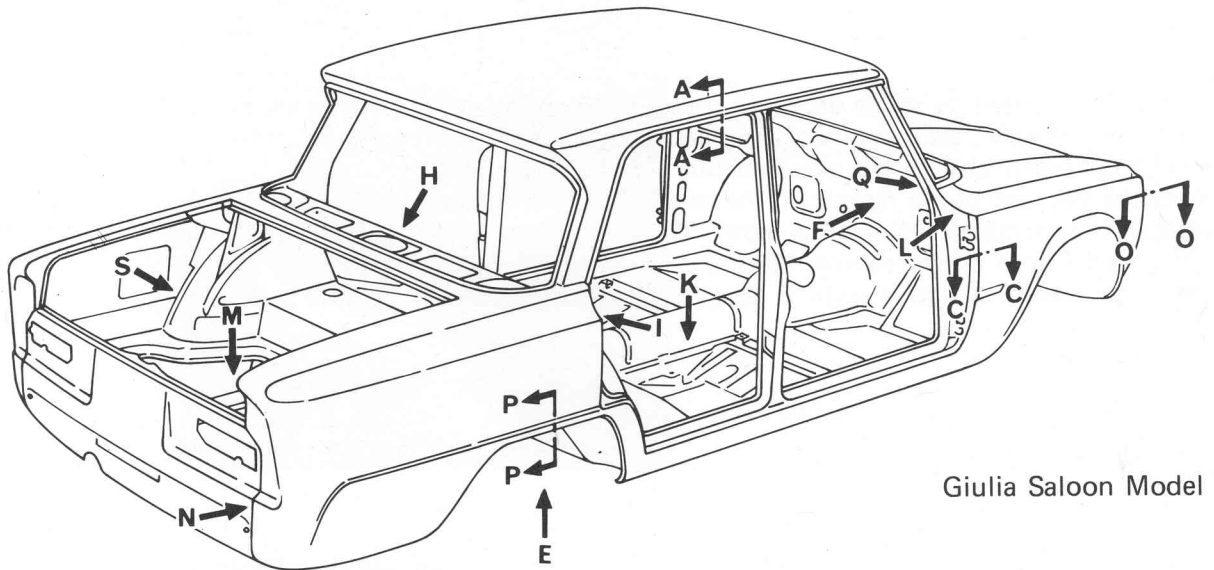

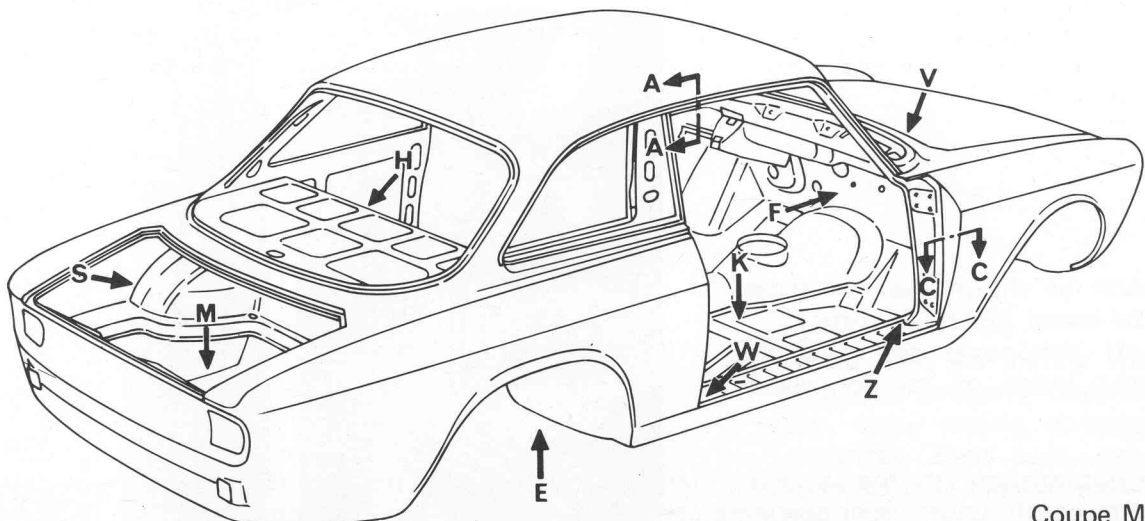

Giulia Saloon Model

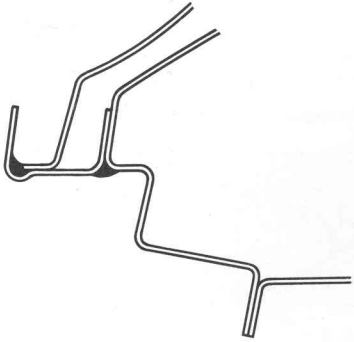
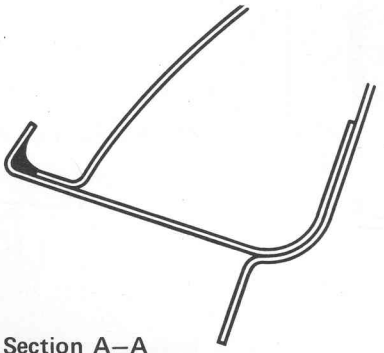

Coupe Model

SEALING

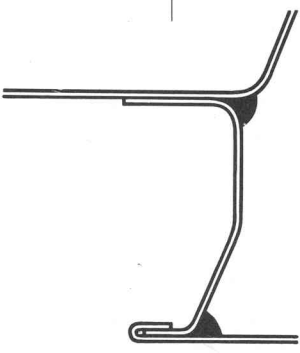
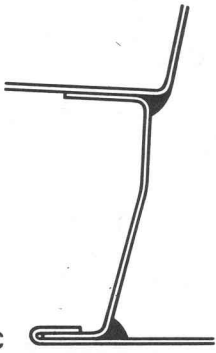
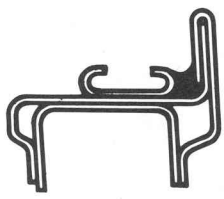
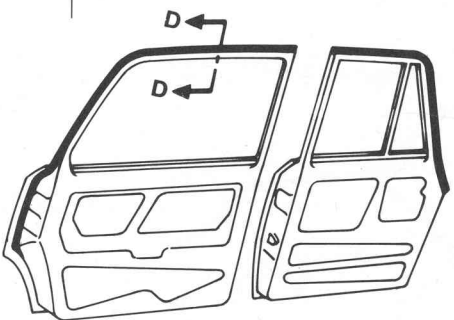

LOCATION	1750 SALOON MODEL	GIULIA SALOON MODELS	COUPE' MODELS
Gutter joining with roof and sides	 <p data-bbox="177 718 477 774">Section A-A Sealing compound type A</p>		 <p data-bbox="1039 718 1332 774">Section A-A Sealing compound type A</p>
Skirt joining with bulkhead	 <p data-bbox="177 1150 477 1205">View from B Sealing compound type B</p>		
Front fender joining with pillars	 <p data-bbox="177 1581 477 1636">Section C-C Sealing compound type B</p>		 <p data-bbox="1039 1581 1339 1636">Section C-C Sealing compound type B</p>
Weatherstrip retainer joining with door frame	 <p data-bbox="177 2001 477 2057">Section D-D Sealing compound type A</p>		

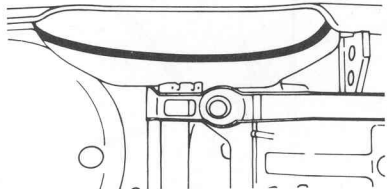
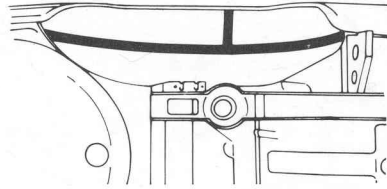
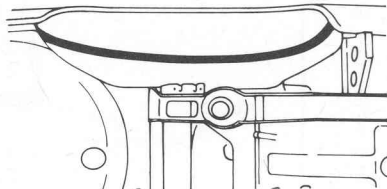
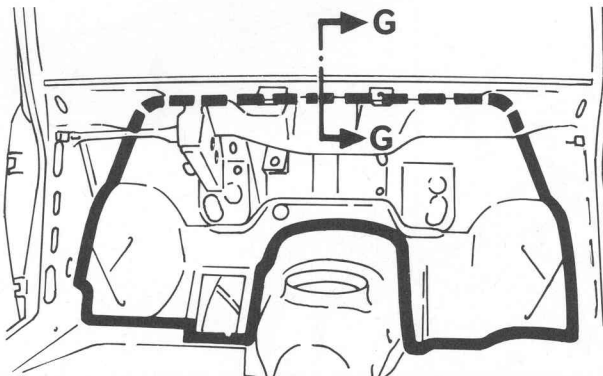
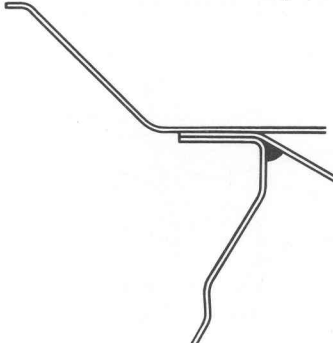
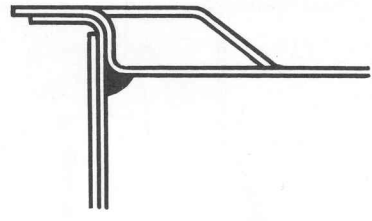
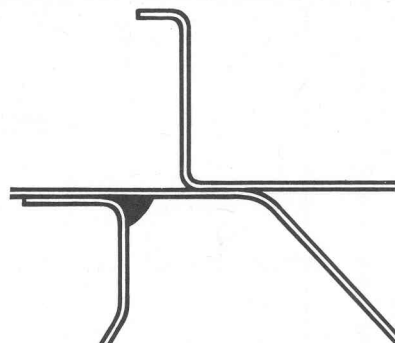
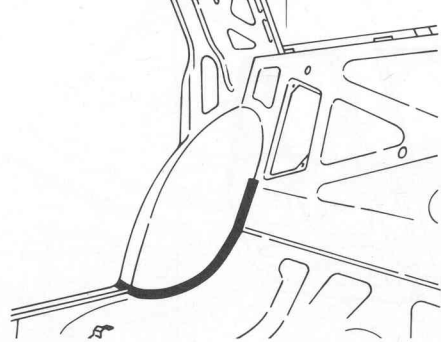
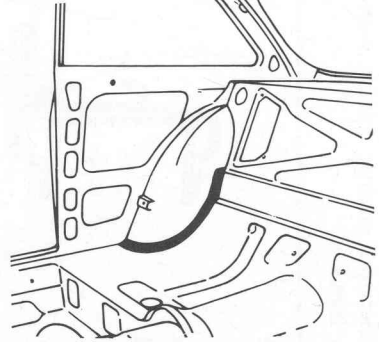
SEALING

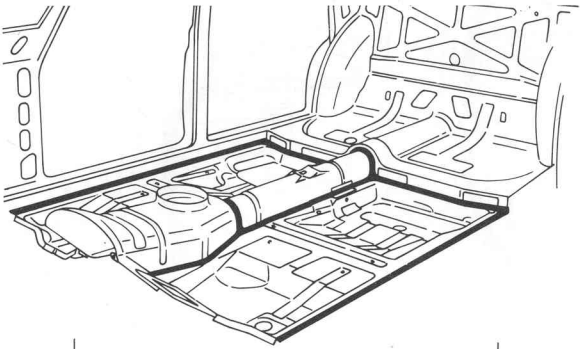
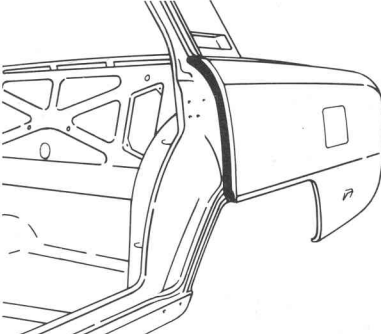
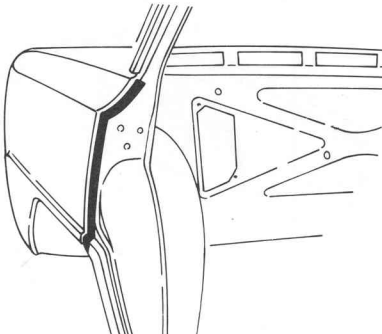
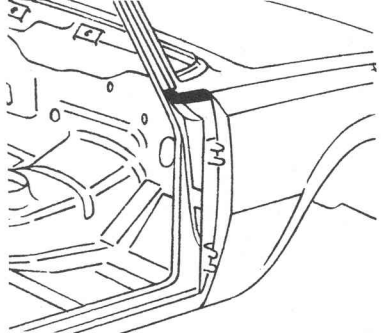
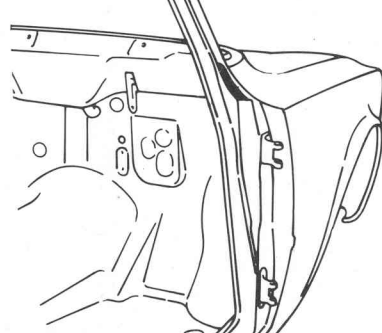
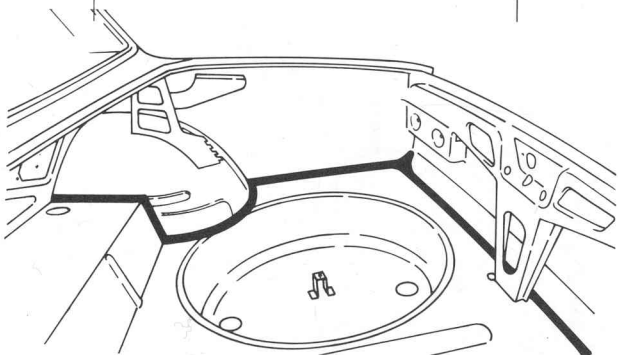

LOCATION	1750 SALOON	GIULIA SALOON	COUPE'
Inner and outer rear wheelarch joinings with side rail end	 <p data-bbox="223 707 515 763">View from E Sealing compound type B</p>	 <p data-bbox="639 707 931 763">View from E Sealing compound type B</p>	 <p data-bbox="1062 707 1355 763">View from E Sealing compound type B</p>
Bulkhead joinings with scuttle and centre floor	<p data-bbox="223 818 408 851">VIEW FROM F</p> 		
	 <p data-bbox="223 1570 515 1625">Section G-G Sealing compound type B</p>	 <p data-bbox="639 1570 931 1625">Section G-G Sealing compound type B</p>	 <p data-bbox="1062 1570 1355 1625">Section G-G Sealing compound type B</p>
Rear pan joining with wheelarch	 <p data-bbox="223 2001 515 2057">View from H Sealing compound type A</p>	 <p data-bbox="1062 2001 1355 2057">View from H Sealing compound type A</p>	

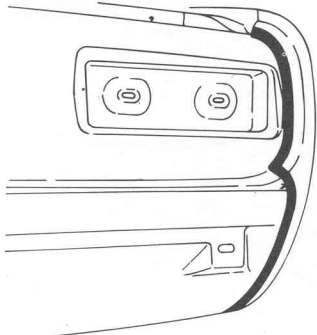
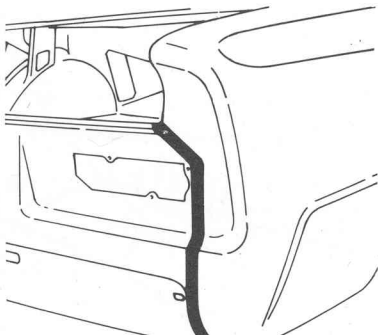
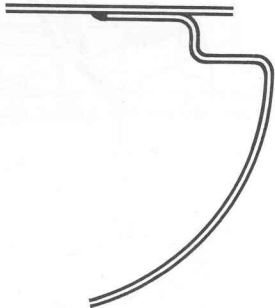
LOCA-TION	1750 SALOON	GIULIA SALOON	COUPE'
Centre pan joinings with tunnel, rear cross member and side rails	 <p data-bbox="189 718 476 774">View from K Sealing compound type B</p>		
Rear wing joining with door jamb	 <p data-bbox="189 1145 476 1201">View from I Sealing compound type A</p>	 <p data-bbox="612 1145 899 1201">View from I Sealing compound type A</p>	
Front wing joining with door jamb top	 <p data-bbox="189 1577 476 1632">View from L Sealing compound type A</p>	 <p data-bbox="612 1577 899 1632">View from L Sealing compound type A</p>	
Luggage compartment floor with wheelarches and tail panel	 <p data-bbox="189 2001 476 2057">View from M Sealing compound type C</p>		

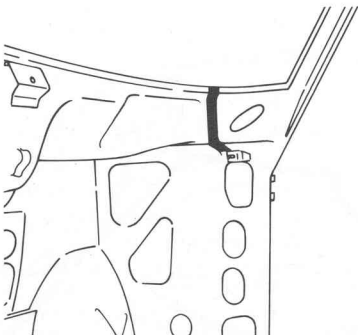
SEALING

LOCATION	1750 SALOON	GIULIA SALOON	COUPE'
Rear wing joining with tail panel	 <p>View from N Sealing compound type A</p>	 <p>View from N Sealing compound type A</p>	
Headlamp housing		 <p>Section O-O Sealing compound type B</p>	
Rear wheelarches joining with rear wings		 <p>Section P-P Sealing compound type B</p>	
Bulkhead joining with wind screen post	 <p>View from Q Sealing compound type B</p>		

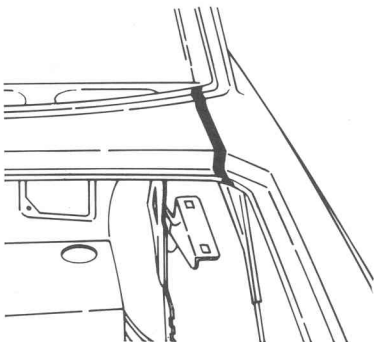
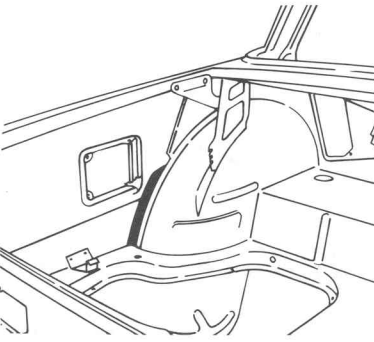
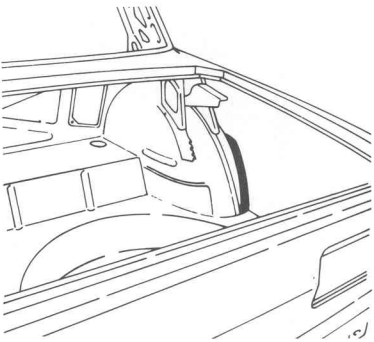
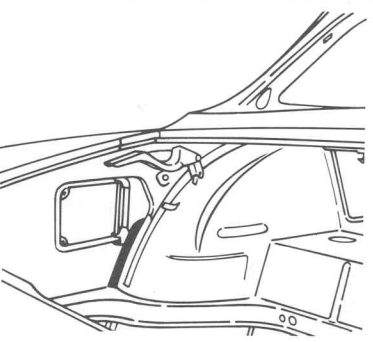
SEALING

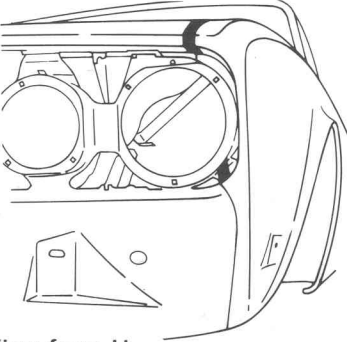
LOCATION	1750 SALOON	GIULIA SALOON	COUPE'
Rear wing joining with luggage compartment, top and tail cross member	 <p>View from R Sealing compound type A</p>		
Wheelarch joining with fender	 <p>View from S Sealing compound type C</p>	 <p>View from S Sealing compound type C</p>	 <p>View from S Sealing compound type C</p>
Blank off rear post drain hole and seal flow away duct	 <p>Section T-T Sealing compound type A</p>		
Front wing joining with front panel	 <p>View from U Sealing compound type A</p>		

SEALING

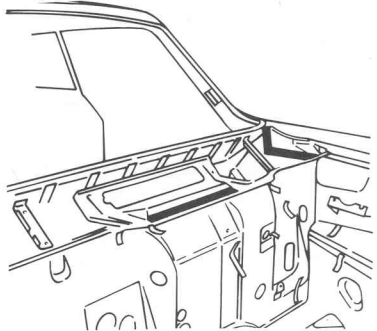
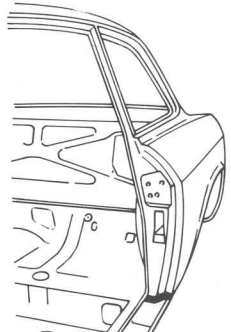
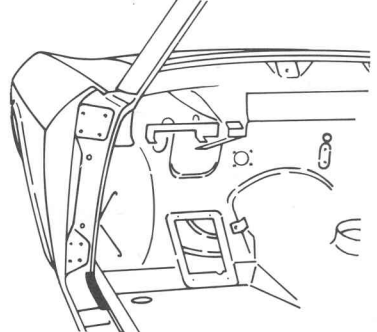
LOCA-TION	1750 SALOON	GIULIA SALOON	COUPE'
Bulkhead joining with scuttle			 <p data-bbox="1085 718 1378 774">View from V Sealing compound type A</p>
Rear wing joining with valance			 <p data-bbox="1085 1150 1378 1205">View from W Sealing compound type A</p>
Front wing joining with valance			 <p data-bbox="1085 1581 1378 1636">View from Z Sealing compound type A</p>

TYPE A:

Particularly suitable for exposed parts and for narrow areas, it consists of only one component and dries at ambient temperature.

- Application procedure:
- Dry sand the joining edges.
- Apply the sealing compound with a syringe or similar, then smooth out with a soft brush.
- After 30-40 minutes drying time at ambient temperature, the sealing compound can be covered with paint and be subject to the baking at 80°C.

TYPE B:

Particularly suitable for non exposed parts and for wider areas, it consists of only one component and dries at ambient temperature.

- Application procedure:
- Dry sand the joining edges.
- Apply the sealing compound with a syringe or similar, then smooth out with a soft brush.
- After 30-40 minutes drying time at ambient temperature, the sealing compound can be covered with paint and be subject to the baking at 80°C.

TYPE C:

It is moulded in a round cross section cord to be applied to large openings; this product retains its original pliability for very long.

- Application procedure:
- Dry sand the joining edges.
- Insert the moulded cord in the slits and blend it to the adjoining parts.

SOUND DEADENER

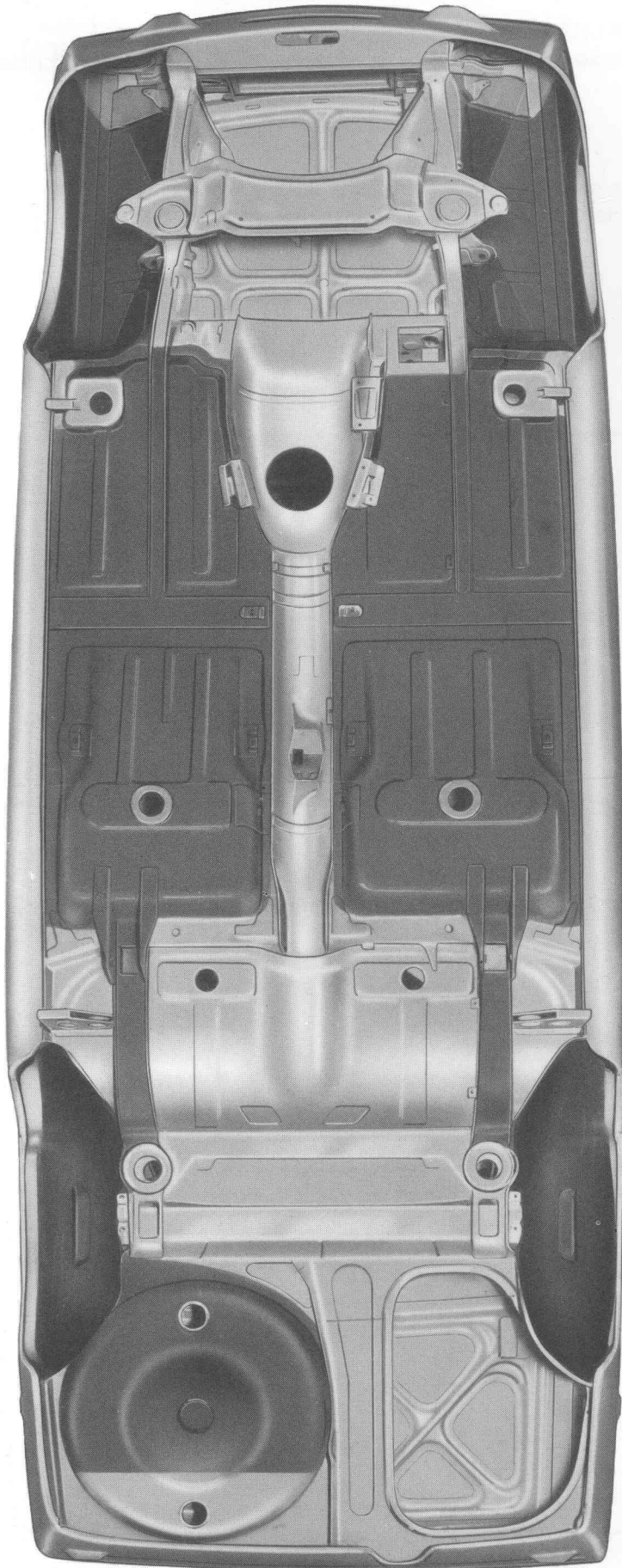

The sound deadener, consisting of bitumen, rubber, asbestos and a solvent is sprayed over the underbody areas to be protected; it dries in 20 minutes at 140°C or in 24 hours at ambient temperature.

The illustration shows the areas of 1750 Saloon underbody where the deadener is applied.

CAUTION – Properly mask off those areas (headlamp seats, mechanical units attachments) where the deadener must not be sprayed.

The cars manufactured by Alfa Romeo are finished either with synthetic enamel or with thermoplastic acrylic lacquer; specifically:

a – PASTEL COLOUR FINISH

Synthetic enamel (oven drying at 140°C)

b – METALLIC FINISH

Thermoplastic acrylic lacquer (oven drying at 140°C)

The refinishing should be accomplished as follows:

– SYNTHETIC ENAMEL FINISH (Type A)

With synthetic enamel dried at 80°C.

– THERMOPLASTIC ACRYLIC LACQUER FINISH (Type B)

With the same acrylic lacquer used for original finish.

Drying can be performed either in an oven at a temperature of 80°C for 1 hour or at ambient temperature for at least 24 hours.

CAUTION – Acrylic lacquer cannot be positively used to repair synthetic enamel finishes and viceversa. Further, never try to use nitro or nitrosynthetic enamels, since these do not afford the same durability as that of specified enamels.

CROSS SECTION OF A TYPICAL FINISH

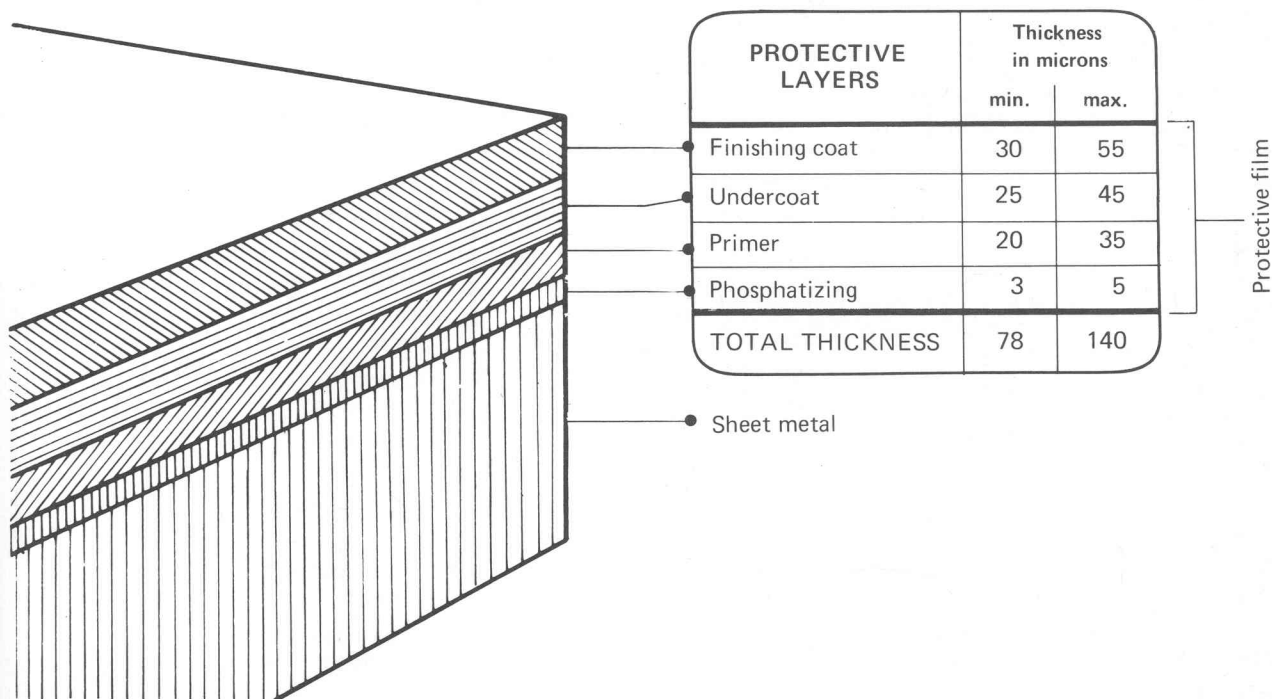

For measuring the thickness of paint coats on a sheet metal, use the magnetic flux gauge, special tool P.N. G.8.0105.

FINISH IDENTIFICATION

To facilitate the identification of finish material, a plate is provided under the luggage compartment lid showing:

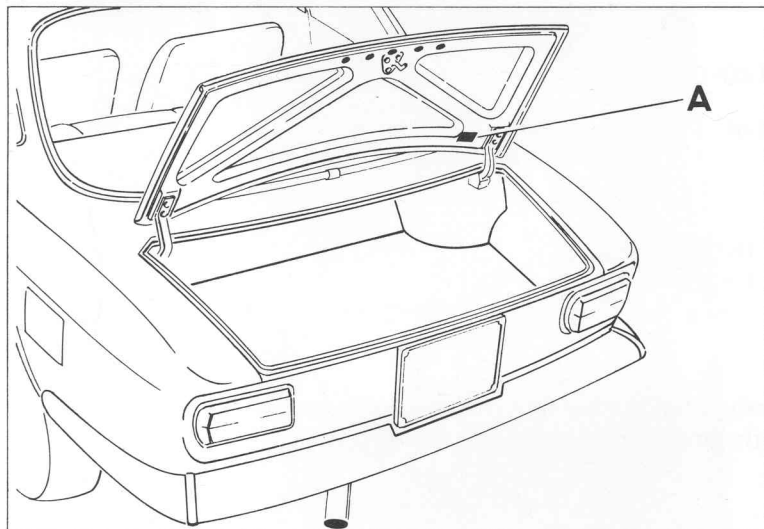

- The manufacturer of the original finish.
- the name of colour as used by Alfa Romeo
e.g. biancospino
 rosso amaranto
 etc.
- The code number of colour as used by Alfa Romeo.
e.g. biancospino 013
 rosso amaranto 509
 etc.

FINISH COLOURS

Name	Code No.	Name	Code No.	Name	Code No.
Acqua di fonte Springwater	701	Biondo champagne Champagne blonde	114	Grigio chiaro met. Medium grey met.	727
Azzurro spazio Space blue	330	Blu chiaro met. Light blue met.	537	Grigio medio met. Silvergrey met.	728
Antracite inglese English graphite	736	Bianco P.F. Farina white	008	Nero Black	901
Avorio P.F. Ivory	103	Bleu P.F. Farina blue	323	Ocra scuro Dark ochre	112
Biancospino White	013	Celeste P.F. Light blue	301	Rosso Alfa Alfa red	501
Beige cava Beige	821	Faggio Dark maroon	516	Rosso amaranto Amaranth	509
Blu olandese Dutch blue	343	Grigio indaco Grey	735	Rosso Italia P.F. Farina red	514
Bluette Petrol blue	327	Giallo Yellow	113	Verde pino Pine green	216
Blu cobalto medio Medium blue	324	Giallo ocra Ochre	109	Verde muschio Dark green	209
Bruno fondo Maroon	818	Grigio grafite Graphite grey	716	Verde oliva met. Olive green met.	213
Blu Francia French blue	342	Grigio beige Beige	724	Verde vivo P.F. Green	217

HOW TO ORDER FINISH MATERIAL

The refinishing material is available both by the Alfa Romeo Spare Parts Department and by the authorised paint suppliers about which the members of Alfa Romeo Service Network have been given full information.

To place orders for refinishing material, it is therefore enough to state the colour name and code number as stamped on the finish plate (see "FINISH IDENTIFICATION") together with the type of paint, that is:

- Synthetic enamel with oven drying at 80°C.
- Thermoplastic acrylic lacquer.

COLOUR MATCHING

Before refinishing, the operator should check the colour shade by comparing the original finish with a sample of the paint prepared for repair coating a piece of sheet metal. Such a specimen should be painted with the same technique as that used for performing the refinishing proper and baked at 80 degrees centigrade for the time specified by the paint manufacturer. Any difference in shade should be corrected by properly tinting the base colours in accordance with the paint manufacturer's instructions. Of course, the successful outcome of refinishing depends, from an aesthetic point of view, on the operator's skill and responsibility.

NOTE – The use of the electric oven and the ultra-violet lamp, special tool P.N. A.9.0100 (see illustration), are recommended for drying the sample of painted sheet metal and comparing its colour shade.

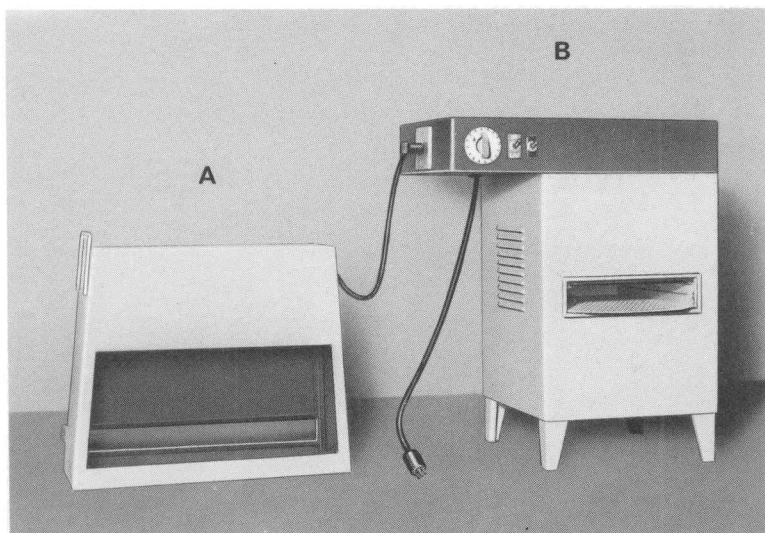

A – Ultra-violet lamp
B – Electric oven

PAINTING PROCESS

Suppliers of refinishing products recommended by Alfa Romeo provide, on body shop's request, full directions on how to use their products. Operators should therefore study carefully these directions and strictly comply with them. However, some general instructions applicable to any product are given below.

PREPARING THE SURFACE

Emphasis is put on the importance of surface preparation since the appearance of a finish will depend considerably upon the condition of the surface over which the paint is applied.

Particularly, special attention should be given to:

a — Bare metal preparation.

The surface shall show no sign of oil or grease and be free from rust. Sanding with no. 180-240 sandpaper and a thorough wiping of the metal with a grease remover are therefore essential.

b — Old finish preparation.

Water sand the old finish with 400-500 grit sandpaper, taking care to featheredge the paint film around the panel being repaired over an area as wider as possible.

NO



YES

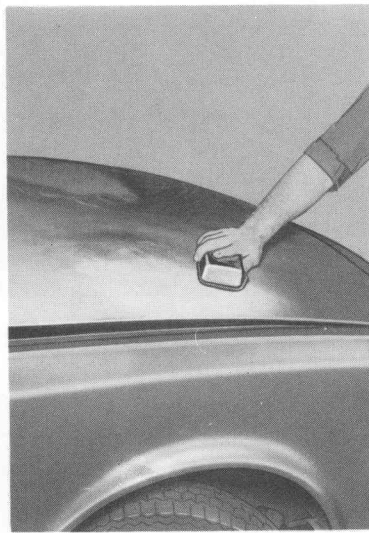

For a surface free from scratches and defects, it is advisable to keep sandpaper or emery cloth flat against the surface to be sanded avoiding using the hand sanding block tipped as shown.

NOTE — To obtain good adhesion, the surface should always be sanded smooth before applying any of the products prescribed in the painting process.

PAINTING PROCESS

After smoothing, the surface to be refinished should be thoroughly cleaned, rinsed with water and then rubbed dry immediately to prevent any water from drying up on the surface. This will avoid tiny bubbles from forming under the paint coating as a consequence of salt residues, present in hard water, remaining on the surface after the water has evaporated. Blistering is caused by osmosis which occurs by the combination of soluble salts and water (atmospheric humidity) through the permeability of the paint film. The operators should take the greatest care not to touch the surfaces so prepared with bare hands since the organic matter left by fingerprints is the major cause of blistering.

RUST INHIBITOR APPLICATION

To prevent the bare metal from oxidizing, never leave the surfaces unprotected for too long, but apply a metal conditioner and rust inhibitor shortly after preparation.

PRIMING AND FILLING

Spraying a primer-surfacer provides a proper filling of any irregularities which may exist in the surface to be painted.

If filling with glazing putty is needed, care should be taken to keep the thickness of coat to a minimum and, in the event several coats are to be applied, let each coat dry up before application of the subsequent one, thus avoiding cracking and shrinking originating from the evaporation of solvent present in the underlying coats.

SEALING

Sealer application is recommended for improving the process and ultimately the appearance of the refinishing, since it prevents thinners from the refinish coat from penetrating into the inner layers and softening and swelling them.

PAINTING PROCESS

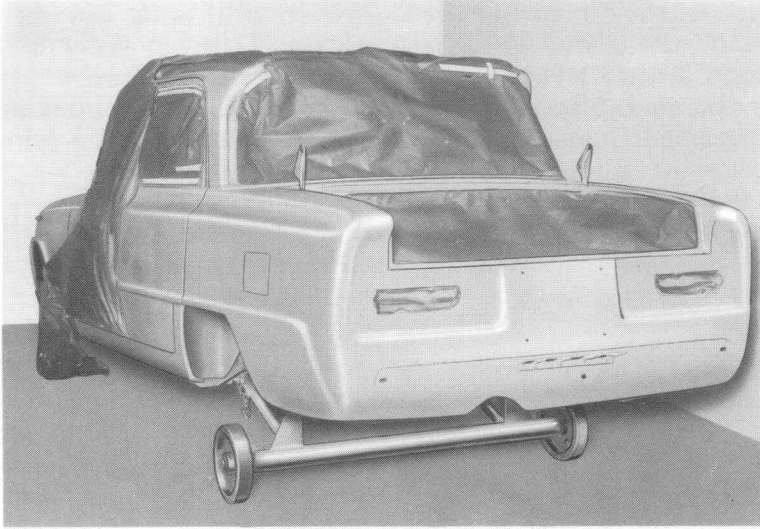

MASKING

Newspapers are not suitable for masking the areas around the section of body to be painted. The special masking paper should instead be used, which, mounted in the masking machine, special tool P.N. A.9.0102, along with the masking tape that is automatically fastened to the paper edge, makes a good masking job and saves time, too.

The masking tape must be top quality to avoid marking the surface that was covered.

PAINT PREPARATION

Before adding thinner, always stir the paint thoroughly to mix uniformly binder and pigment settled to the can bottom during storage.

When preparing paint for use, strictly follow the manufacturer's directions both as to the type of thinner to be added and the amount of thinning to spraying viscosity.

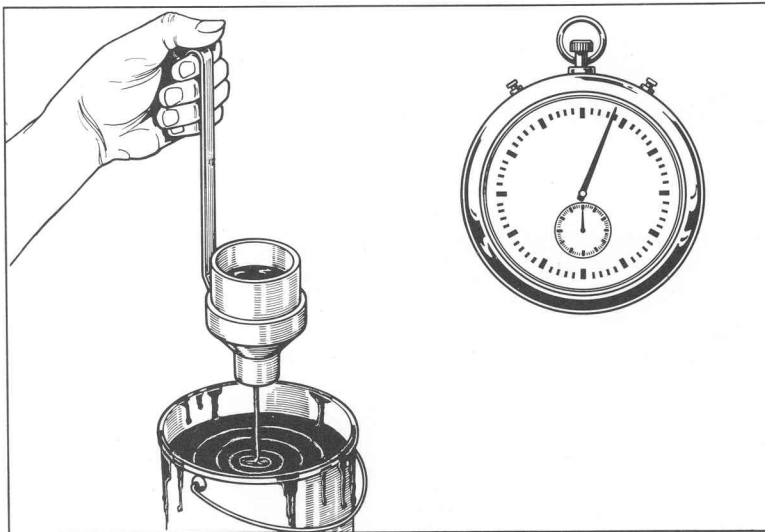

Paint viscosity should be tested with the Ford viscosity cup, special tool P.N. G.8.0101, with 100 cubic centimetres capacity and a 4 mm dia. orifice; viscosity is determined as to the number of seconds required for 100 cc. of paint to flow through the orifice at 20°C temperature. To obtain the proper spraying viscosity, add either unthinned paint or thinner as required.

It should be kept in mind that viscosity is closely related to temperature; it is thereby essential that, before testing the viscosity, paint is brought to the prescribed temperature of 20°C.

Before spraying, strain the paint with a nylon or a fine mesh gauze to remove any foreign matter.

PAINTING PROCESS

PAINT APPLICATION

Satisfactory results are strictly dependent on the efficiency of the equipment and the spraying technique used. A thorough filtering of compressed air is essential to avoid printing flaws such as fish eyes, cratering, dusting, dirt in finish, etc. Care should also be taken that both air pressure and spray nozzle diametres are in accordance with those recommended for the painting process (G.9.0012 spray gun for undercoats with 1.8 mm dia. nozzle; G.9.0022 spray gun for top coats with 1.2 mm dia. nozzle; G.9.0030 spray gun of gravity type for spot touch up with 2 mm dia. nozzle); besides, in the spray booth, the operators should avoid wearing dusty or wollen clothes which tend to introduce foreign matter.

Both the spray booth and the drying oven must meet these specifications:

- To be located in as dust free an ambient as possible;
- Supplied with filtered dust-free air;
- Even, turbulence-free air circulation at such a rate as to exhaust spraying fumes before they fall down on painted surface.
- Constant temperatures of 20-25°C during spraying and flashing and 80°C during baking. Temperature readings are to be taken all around the body with a thermometre.

These requirements avoid any inconvenience that might impair the outcome of refinishing such as:

- Dust trapped into the finish coat requiring mechanical polishing which is totally unnecessary when using 80°C synthetic enamels;
- An excess of orange peel;
- Insufficient baking causing the downgrading of the quality characteristics of paints (inadequate hardness of paint film; less durability).

Before the car is brought into the spray booth, the underbody and the wheelarches must be carefully washed to get rid of any dust and mud.

It is possible to carry a car in running order into an oven at 80 degrees centigrade provided that the following precautions are taken:

- Remove fuel from tank;
- Remove tank filler plug and blank off the port with paper; make a hole through it for vent;
- Deflate tyres;
- Remove the battery;
- Remove the windscreen or mask it with asbestos.

PAINTING PROCESS

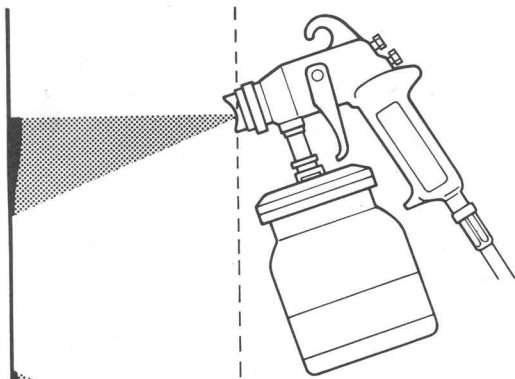

NO

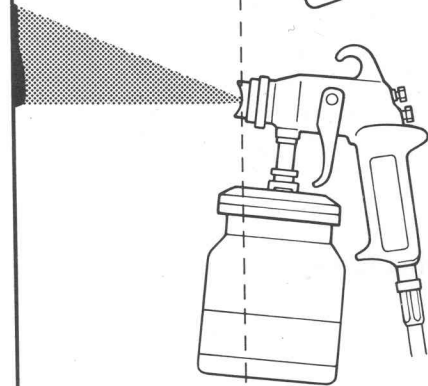

NO

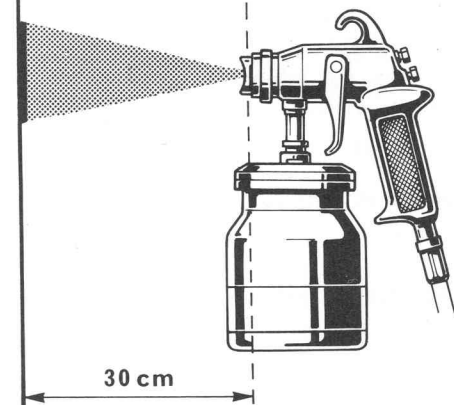

YES

For a correct spraying technique, proceed as follows:

- The gun must be held 1 foot from the panel being sprayed.
- The gun must be held at 90° to the panel.
- Move the gun parallel to the surface.

The above recommendations should be strictly complied with to avoid troubles such as:

- Too close a distance, causing sags and too heavy a coat.
- Too far a distance, causing excessively dry coating and dusting.
- Gun tilting, resulting in runs and sags where the spray is closer to the surface.

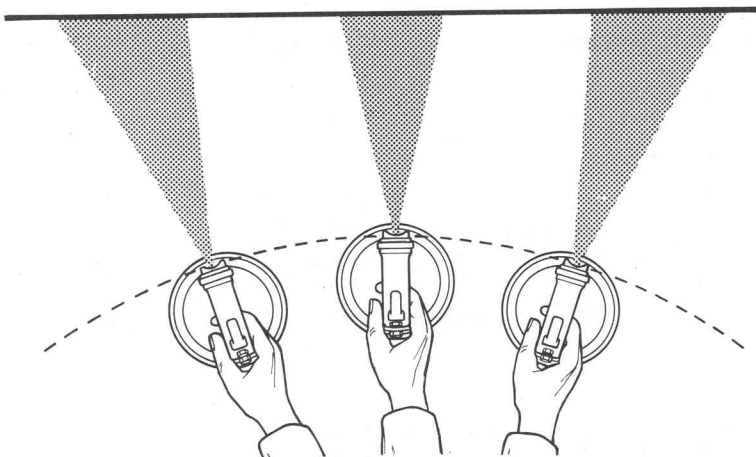

NO

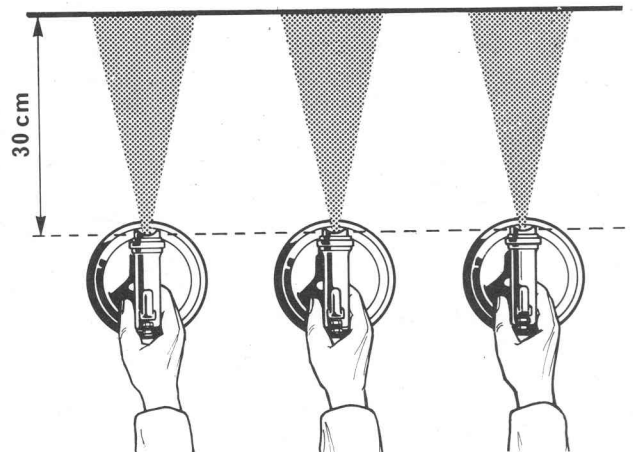

YES

PAINTING PROCESS

INFRARED LAMPS

For spot touch up, when a drying oven is not available, infrared lamps (such as the portable lamp, special tool P.N. G.9.0050) may be used to bake the enamel without applying heat to sections of body not affected by paint repairs. It is however essential that heat is applied at the appropriate distance to avoid damage from overheating or possible change in shade.

POLISHING

Polishing is necessary to produce a glossy finish on acrylic lacquer while it is not indispensable on 80°C synthetic enamels as, after baking, they already have the proper lustre and smoothness.

If, for the reasons mentioned on page 91, the finish shows imperfections caused by dirt trapped in the finish coat, they must be rubbed out by water sanding with 600 grit sandpaper and polished with a mechanical compound.

For a proper mechanical polishing, the following should be kept in mind:

- Carry out polishing after the body has cooled down.
- Use polishing machines turning at about 2000 rpm.
- Make sure the polishing disc is free from dirt left by previous polishing operations.
- Handle the power wheel so that not too much pressure is applied against the work or the finish coat will be overheated and scratched.

NO

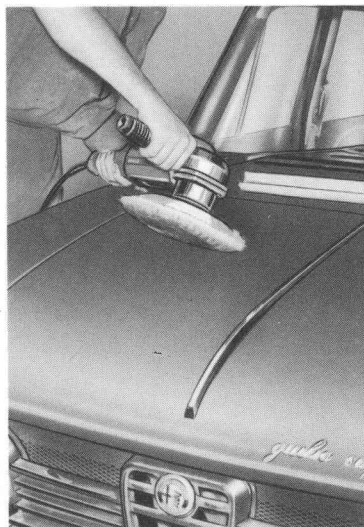

YES

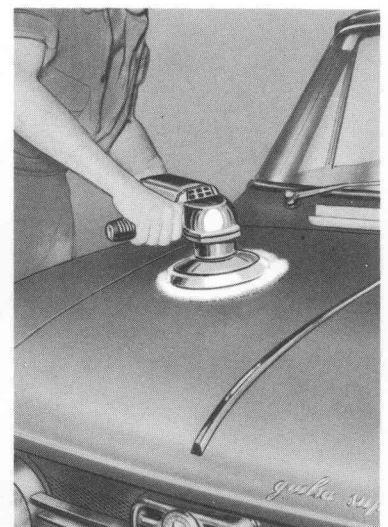

- Never hold the wheel at too great an angle, but flat or just slightly tipped.

REFINISHING

PAINTING PROCESS

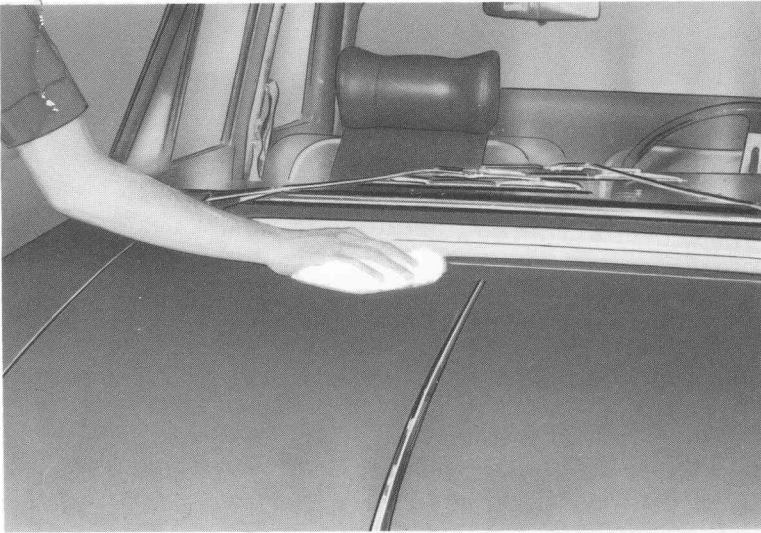

Compound by hand to finish polishing.

PAINTING TROUBLES

To close the argument about paint repairs, some suggestions are given below on how to trace down troubles to their actual causes (refer to trouble-shooting chart on page 96 et seq.) thus enabling the operators to select the proper procedure for a rapid correction.

TRACING

— Visually

To be performed with the aid of a 5-10 x magnifier and after the car has been carefully washed and dried.

— By the touch.

To be performed by feeling the surface being examined.

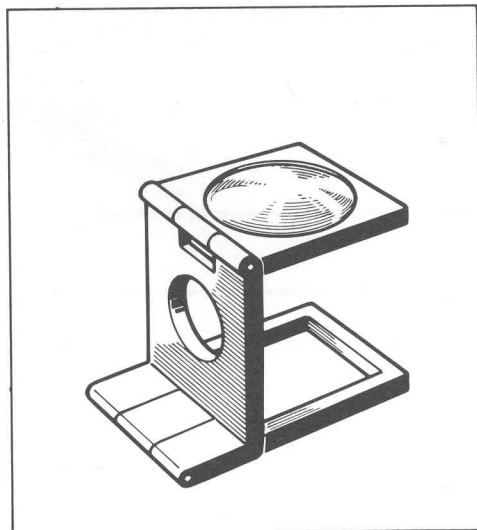

- Polishing by hand.
- Compounding by hand.
- Water sanding with 600 grit used sandpaper and polishing.

To be accomplished in case of superficial imperfections without alteration of top coat.

- By cutting through with a sharp-edged tool.

To be performed when the blemish affects deeply the finish coat. In this way it is easy to determine to what extent the inner layers are involved.

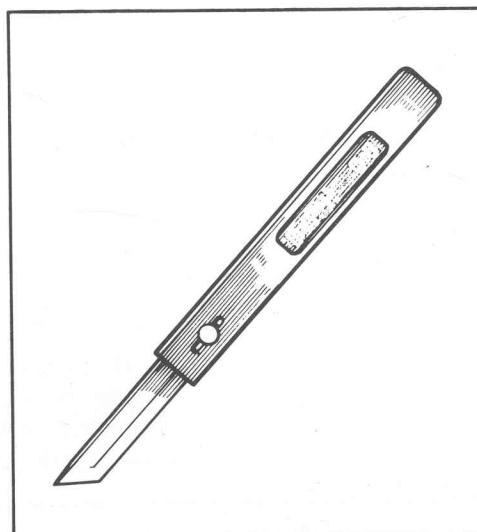

PAINTING TROUBLE SHOOTING

APPEARANCE	TRACING	CAUSE
------------	---------	-------

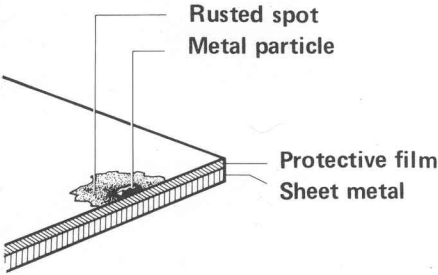

<p>1 – YELLOW SPOTS</p> <p>Rusted spots surrounding the particle which caused the trouble. These imperfections show up on horizontal/flat sections and by contrast on lighter shades.</p>	<p style="text-align: center;">Visually and by the touch</p>  <p style="text-align: center;">Rusted spot Metal particle</p> <p style="text-align: center;">Protective film Sheet metal</p>	<p>Motes deposited and imbedded into the paint film.</p>
--	---	--

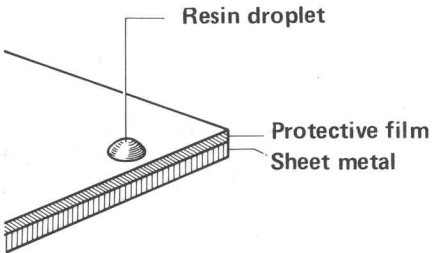
<p>2 – PURPLISH SPOTS</p> <p>Purplish spots of various size and shape evenly spread over horizontal/flat sections. These imperfections show up on dark finish.</p>	<p style="text-align: center;">Visually</p>	<p>Deposits over the paint film due to chemical fumes, water, tree sap.</p>
---	---	---

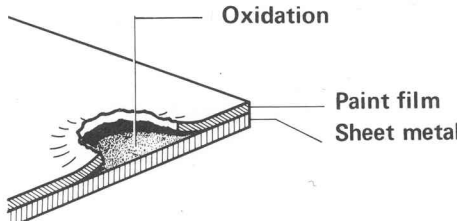
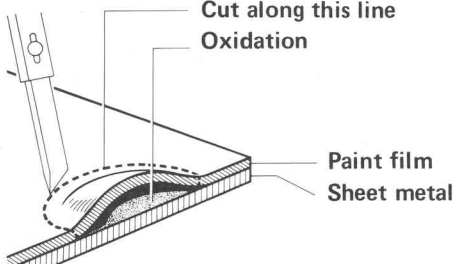

<p>3 – TREE SAP</p> <p>Resin droplets, dark in colour, scattered mostly over horizontal/flat sections.</p>	<p style="text-align: center;">Visually and by the touch</p>  <p style="text-align: center;">Resin droplet</p> <p style="text-align: center;">Protective film Sheet metal</p> <p style="text-align: center;">It is recommended to use an octane base solvent to prevent spreading sap while trying to wipe it off.</p>	<p>Deposits over the paint film of sap dropped from plants.</p>
---	---	---

If the contaminants causing these troubles are allowed to act for too long, the paint film may be seriously damaged. It is therefore advisable to remove these imperfections timely; the sooner their removal (an operation included in regular car servicing) is performed, the much less it will cost.

PAINTING TROUBLE SHOOTING

APPEARANCE	TRACING	CAUSE
<p>4 – DISCOLORATION</p> <p>Variations in colour and, when badly affected, alterations of the paint film (cracking, swelling, corrosion in various patterns).</p>	<p>Visually</p>	<p>Spotty discoloration of surface resulting from atmospheric contamination (such as smog, chemical fumes, etc.) or other contaminants, such as brake fluid, battery acid, cement dust, road tar, bird dung, etc.</p>
<p>5 – STONE BRUISES – SCORING – DENTS</p> <p>Broken paint film resulting in the oxidation of the exposed metal and raising of surrounding finish (crater-like swelling).</p>	<p>Visually</p> 	<p>Stone bruises, shocks, rubbing, impact of other car bumpers or doors as while parking.</p>
<p>6 – DULL AND SOFT FINISH</p> <p>The finish is dull and can be easily scraped.</p>	<p>Visually and by scratching with a finger nail.</p>	<p>Use of caustic cleaners or solvents when washing or servicing the car.</p>
<p>7 – BLISTERS (rust under finish)</p> <p>Spots raised by 2-3 mm from sheet metal.</p>	<p>Cut blisters to see whether the metal underneath shows oxidation.</p>  	<p>Improper metal preparation (refer to page 88 parag. A).</p>

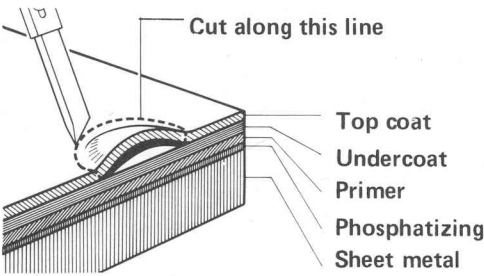
PAINTING TROUBLE SHOOTING

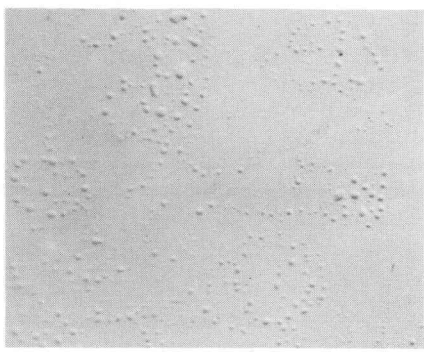
APPEARANCE	TRACING	CAUSE
<p>8 – BLISTERING</p> <p>Small areas (1-2 mm) of top coat swelled above the undercoat.</p>	<p>Cut blisters to see whether the undercoat is affected.</p>  <p>Cut along this line</p> 	<p>Inadequate surface preparation (refer to pages 88-89).</p>
<p>9 – WATER SPOTTING</p> <p>Dulling of gloss in various patterns mostly surrounded by very small blisters.</p>	<p>Visually</p> 	<p>Spots of water drying on finish coat or on undercoat that are not thoroughly dry. Operator's fingerprints left on the surface before applying the finishing coat (refer to page 89).</p>
<p>10 – FINISH DISCOLORATION Paint shade lighter than original</p>	<p>Visually</p>	<p>Weathering.</p>
<p>11 – FINISH COLOUR DARKENING Paint shade darker than original.</p>	<p>Visually</p>	
<p>12 – FINISH COLOUR TURNED YELLOW (lighter shades) Original enamel colour turned yellow.</p>	<p>Visually</p>	

PAINTING TROUBLE SHOOTING

APPEARANCE	TRACING	CAUSE
<p>13 – TOTAL CHANGE OF ENAMEL COLOUR</p> <p>The enamel coat shows a colour totally different from the original.</p>	Visually	Chemical change of pigments resulting from atmospheric contamination (chemical fumes).
<p>14 – LINE CRACKS AND CROWFOOT CHECKS</p> <p>The enamel film shows line crack and crowfoot checks.</p>	Visually	<ul style="list-style-type: none"> – Failure by exposure to weather. – Insufficient drying of films prior to re-coating (see page 89). – Thinners added to a product not designed for it (incompatibility). – Recoating a previously cracked finish.
<p>15 – DULLED FINISH</p> <p>Loss of gloss. Paint film fails to shine after polishing.</p>	Visually, before and after polishing.	<ul style="list-style-type: none"> – Weathering of paint film. – Use of caustic cleaners or solvents when washing or servicing the car.
<p>16 – DULL AND SCRATCHED FINISH.</p> <p>Paint film lacks lustre and polishing scratches show up distinctly.</p>	Visually	Improper polishing (refer to page 93).
<p>17 – LACK OF TOP COAT</p> <p>Lack of top coat so that undercoats can be seen.</p>	Visually	Insufficient colour coats.

PAINTING TROUBLE SHOOTING

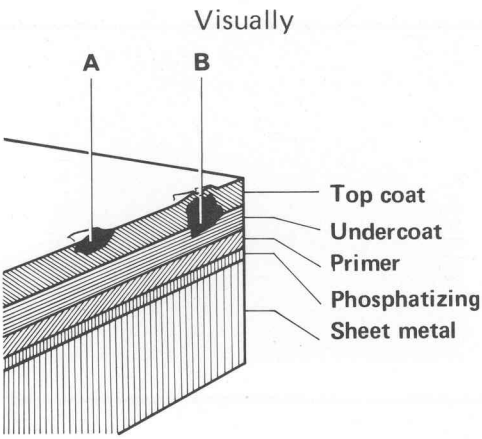
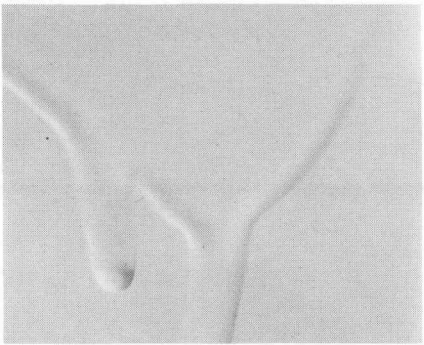
APPEARANCE	TRACING	CAUSE
<p>18 – PEELING</p> <p>The top coat separates easily from undercoats.</p>	<p>By scratching with a finger nail to see whether the top coat comes off.</p>	<p>Improper surface preparation before applying paint (refer to page 88).</p>
<p>19 – INADEQUATE PAINT FILM HARDNESS</p> <p>The film can be easily scratched.</p>	<p>By scratching with a finger nail.</p>	<ul style="list-style-type: none"> – Insufficient baking of film. – Too heavy a coat of enamel.
<p>20 – UNDERCOAT SCRATCHES SEEN THROUGH THE TOP COAT</p> <p>Deep scratches can be perceived beneath the top coat.</p>	<p>Visually</p>	<p>Improper surface preparation (refer to page 88 parag. b).</p>
<p>21 – DIRT IN FINISH</p> <p>The paint film shows imperfections (in an amount not negligible) due to foreign particles dried in the paint film.</p>	<p>Visually</p> 	<p>Foreign particles dried in the top coat (as in A) or in the undercoat (as in B) (also refer to page 91).</p> <p>The imperfection shown in A can be remedied by rubbing out finish then polishing it.</p>
<p>22 – RUNS</p> <p>Running of too heavy a paint film in rivulets.</p>	<p>Visually</p> 	<p>Improper spraying (refer to page 92).</p>

PAINTING TROUBLE SHOOTING

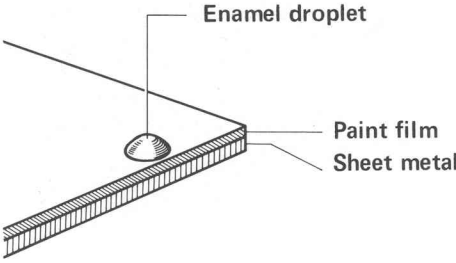
APPEARANCE	TRACING	CAUSE
<p>23 – UNDERCOAT SHOWING</p> <p>Too thin a top coat allows the undercoat to be seen through.</p>	Visually	<ul style="list-style-type: none"> – Insufficient film thickness. – Repeated rubbing with polishing compound removes layers of top coats.
<p>24 – UNEVEN THICKNESS OF TOP COAT</p> <p>Touched up areas not flush with each other.</p>	Visually	Improper finish.
<p>25 – DROPLETS OF ENAMEL</p> <p>Very small droplets of enamel resulting in a rough surface.</p>	Visually and by the touch	 <p>The diagram illustrates a cross-section of a sheet metal surface. A thin layer of paint film is applied to the surface. A small, spherical enamel droplet is shown on the surface of the paint film. Labels with leader lines point to the 'Enamel droplet', the 'Paint film', and the 'Sheet metal'.</p>
<p>26 – HALO AROUND PAINT REPAIR</p> <p>Line contouring the touched up area.</p>	Visually	Improper touch up.
<p>27 – UNEVEN ORANGE PEEL</p> <p>Resembling the peel of an orange with uneven distribution over the surface.</p>	Visually	<ul style="list-style-type: none"> – Paint preparation (viscosity; refer to page 90). – Paint application (refer to page 91). – Surface preparation (Sanding; refer to page 88).

PAINTING TROUBLE SHOOTING

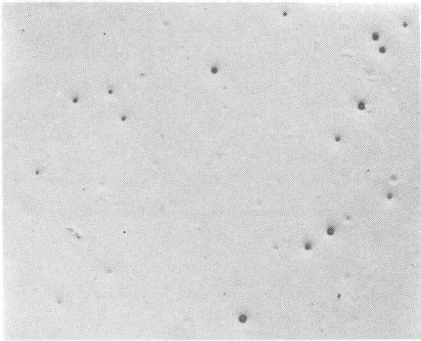
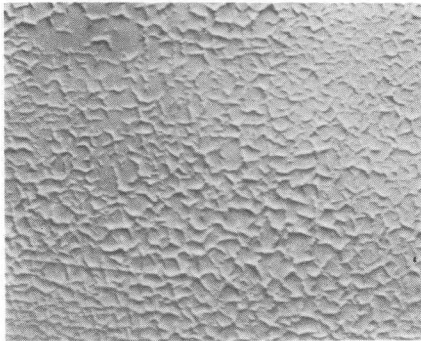
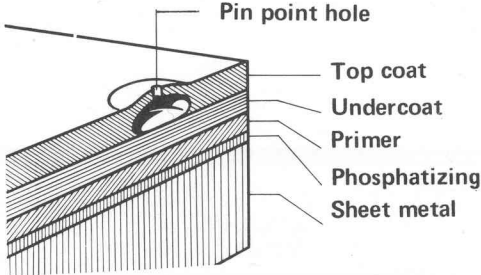
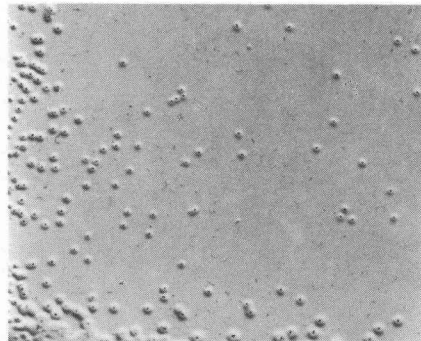
APPEARANCE	TRACING	CAUSE
<p>28 – FISHEYES</p> <p>Separation of paint film; the undercoat may be seen in spots when the top coat is badly affected.</p>	<p>Visually</p> 	<ul style="list-style-type: none"> – Improper cleaning of old surface (presence of silicone) before recoating. – Defective spraying equipment (presence of oil; refer to page 91).
<p>29 – LIFTING</p> <p>Raising and swelling of the paint film.</p>	<p>Visually and by the touch</p> 	<ul style="list-style-type: none"> – Improper drying of previous coating. – Improper recoating (acrylic on nitro; enamel on nitro; acrylic on enamel).
<p>30 – PIN POINT BLISTERING (overheating)</p> <p>Paint film shows clusters of pin point holes.</p>	<p style="text-align: center;">Visually</p>  	<ul style="list-style-type: none"> – Force drying before solvents have flashed off (refer to pages 89 and 93). – Too fast a drying of surface.

LIST OF SPECIAL TOOLS

Alfa Romeo P.N.	Nomenclature	Page
A.8.0901	Body alignment checking bench	7
A.8.0109	Fixture for cross member replacement	20
A.8.0112	Extension gauge for windscreen frame checking	30
A.9.0104	Stand for glass resting	32
A.9.0035	Pliers for fitting windscreen corner finishers	35
A.9.0103	Tool for straightening bow fastening hooks	63
A.8.0104	Template for aligning strikers of KEIPER locks	66
A.8.0102	Template for aligning strikers of SAFE locks	67
A.8.0103	Template for checking the catch of SAFE locks	67
M.6.0101	Vacuum pump for water testing	75
G.8.0105	Magnetic flux gauge for paint film thickness	85
A.9.0100	Electric oven and lamp for colour matching	87
A.9.0102	Masking machine	90
G.8.0101	Viscosity cup (FORD 4)	90
G.9.0012	Spray gun for undercoats, 1.8 mm dia. nozzle	92
G.9.0022	Spray gun for top coats, 1.2 mm dia. nozzle	92
G.9.0030	Gravity spray gun for spot touch up, 2 mm dia. nozzle	92
G.9.0050	Portable infrared lamp for paint baking	93

Alfa Romeo

Via Gattamelata, 45 - 20149 MILANO

DIASS - Pubblic. N. 1570
9/70 - 2.500

Printed in Italy
LITOROLA - MILANO

Printed on 113 and 200 gr. paper,
type Tevere, produced by
Cartiera del Sole.

All rights reserved. This book, or parts thereof,
may not be reproduced in any form without
permission of ALFA ROMEO S.p.A.

